



DAMAGE REPORT AND CLASSIFICATION
DA 40 - Series

DAI-C Form: E34_DA 40 Rev -. 17-May-2024.

Submit to: Diamond Aircraft Industries Inc.
1560 Crumlin Sideroad,
London, Ontario, Canada, N5V 1S2
Tel: (519) 457-4041
Fax: (519) 457-4045
support-canada@diamondaircraft.com

Date of damage:		<p>Notes:</p> <ul style="list-style-type: none"> a) Damage classification must be carried out by certified staff or approved maintenance organisation. b) In case of FRP-damages, the damage classification must be carried out according to the latest revision of the Airplane Maintenance Manual, Section 51-10. c) In case of contact with salt water: Clean all mechanical parts within 48 hours after recovery from salt water. <p>Short description of damage(s), cause of damage / classification acc. to AMM, reference for pictures:</p>
AIRPLANE		
Type:		
Serial No.:		
Call Sign:		
TSN:		
Operator:		
ENGINE		
Type:		
Serial No.:		
TSN:		
TSO:		
PROPELLER		
Type:		
Serial No.:		
TSN:		
TSO:		
SN of effected system parts: note on further pages		

Statement:

I hereby declare that the damage(s) has(have) been classified acc. to AMM (section 51-10 for FRP damage) and all relevant damages on the aircraft have been described.

(person / company / location):

.....

Date:		Stamp, Signature:	Page of
Revision:			



DAMAGE REPORT AND CLASSIFICATION
DA 40 - Series

DAI-C Form: E34_DA 40 Rev -. 17-May-2024.

Submit to: Diamond Aircraft Industries Inc.
1560 Crumlin Sideroad,
London, Ontario, Canada, N5V 1S2
Tel: (519) 457-4041
Fax: (519) 457-4045
support-canada@diamondaircraft.com

Position of damage(s):

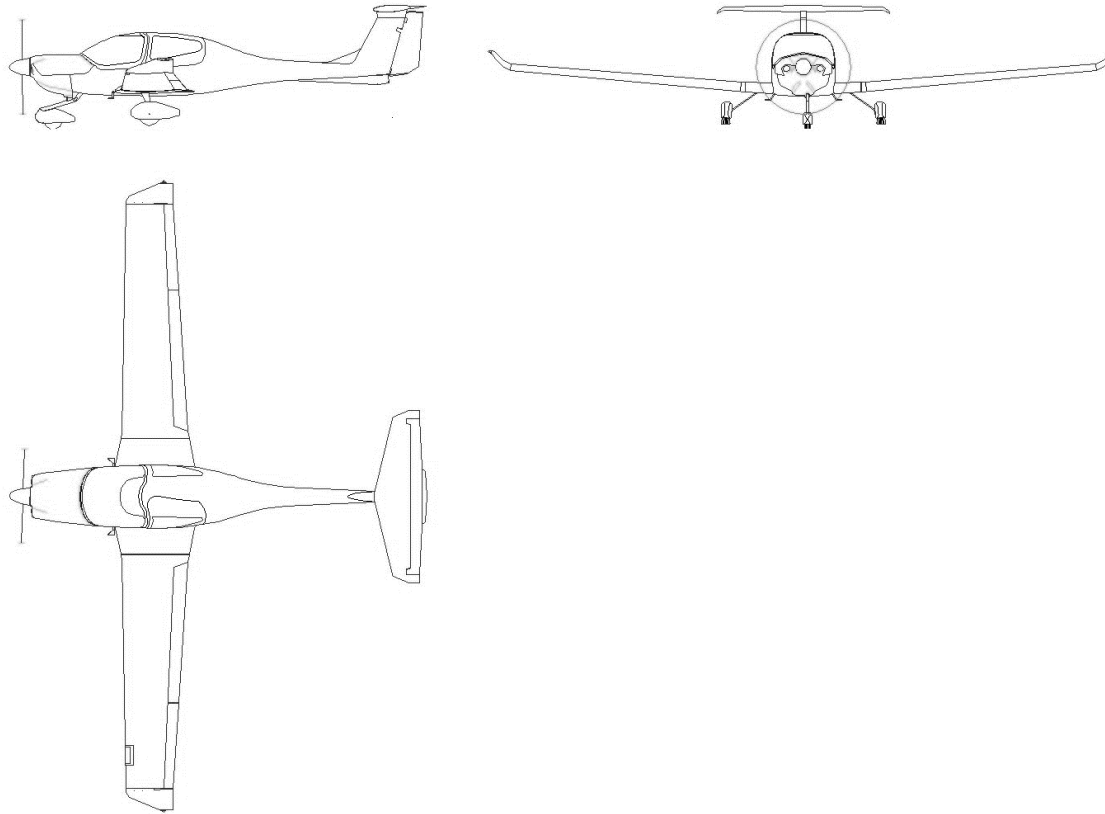

Date:		Stamp, Signature:	Page of
Revision:			



DAMAGE REPORT AND CLASSIFICATION
DA 40 - Series

DAI-C Form: E34_DA 40 Rev -. 17-May-2024.

Submit to: Diamond Aircraft Industries Inc.
1560 Crumlin Sideroad,
London, Ontario, Canada, N5V 1S2
Tel: (519) 457-4041
Fax: (519) 457-4045
support-canada@diamondaircraft.com

Pos.	Detailed description / Size of Damage	Classification	Reference to attached pictures	Proposed Repair

Date:		Stamp, Signature:		Page of
Revision:				