



DAMAGE REPORT AND CLASSIFICATION

DA 20 A1 / DA 20 C1 - Series

DAI-C Form: E21 Rev. B, 17-May-2024,

Submit to: Diamond Aircraft Industries Inc.
 1560 Crumlin Sideroad,
 London, Ontario, Canada, N5V 1S2
 Tel: (519) 457-4041
 Fax: (519) 457-4045
support-canada@diamondaircraft.com

Date of damage:		<p>Notes:</p> <p>a) Damage classification must be carried out by certified staff or approved maintenance organisation. b) In case of FRP-damages the damage classification must be carried out according to the Airplane Maintenance Manual, Section 51-00, latest revision. c) In case of contact with salt water: Clean all mechanical parts within 48 hours after recovery from salt water</p> <p>Short description of damage(s), cause of damage / classification acc. to AMM, reference for pictures:</p>
AIRPLANE		
Type:		
Serial No.:		
Call Sign:		
TSN:		
Operator:		
ENGINE 1		
Type:		
Serial No.:		
TSN:		
TSO:		
PROPELLER 1		
Type:		
Serial No.:		
TSN:		
TSO:		
SN of effected system parts: note on further pages		

Statement:

I hereby declare that the damage(s) has(have) been classified acc. to AMM (section 51-10 for FRP damage) and all relevant damages on the aircraft have been described.

(person / company / location):

.....

Date:		Stamp, Signature:	Page of
Revision:			



DAMAGE REPORT AND CLASSIFICATION

DA 20 A1 / DA 20 C1 - Series

DAI-C Form: E21 Rev. B, 17-May-2024,

Submit to: Diamond Aircraft Industries Inc.
1560 Crumlin Sideroad,
London, Ontario, Canada, N5V 1S2
Tel: (519) 457-4041
Fax: (519) 457-4045
support-canada@diamondaircraft.com

Position of damage(s) DA20 A1:

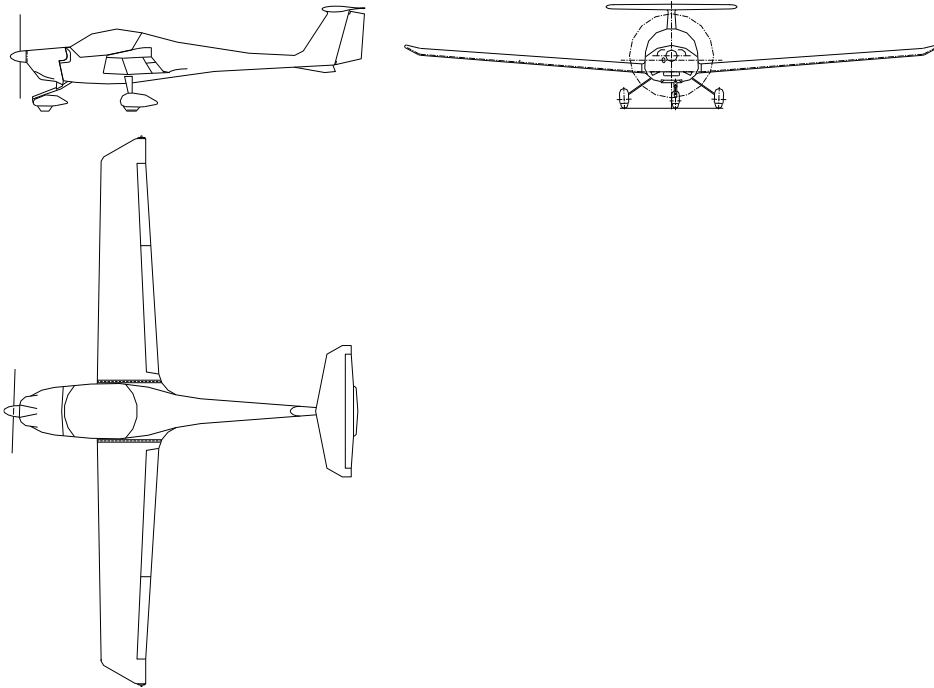

Position of damage(s) DA20 C1:

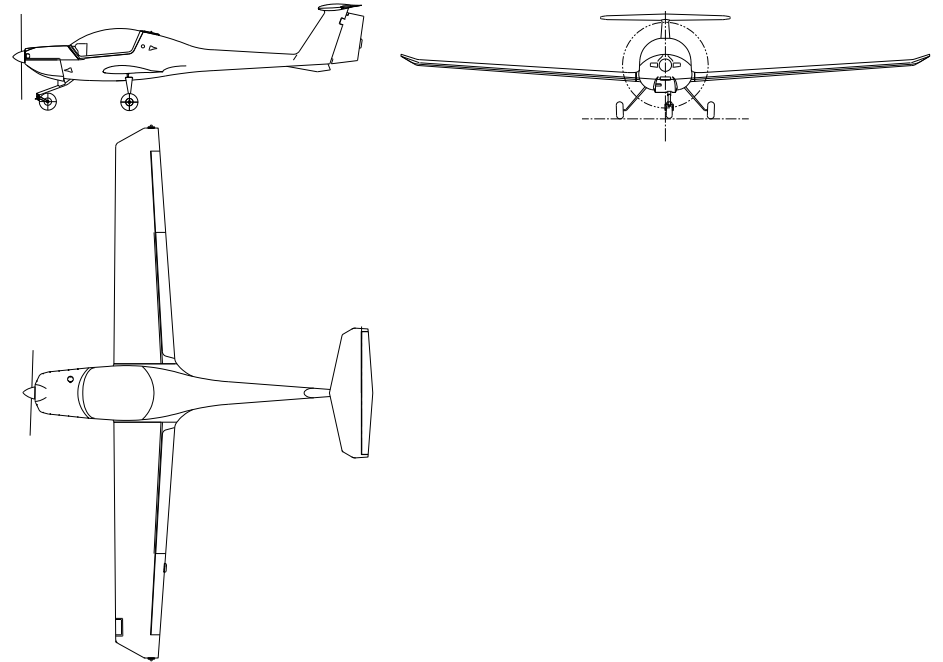

Date:

Revision:

Stamp, Signature:

Page
of



DAMAGE REPORT AND CLASSIFICATION

DA 20 A1 / DA 20 C1 - Series

DAI-C Form: E21 Rev. B, 17-May-2024,

Submit to: Diamond Aircraft Industries Inc.
1560 Crumlin Sideroad,
London, Ontario, Canada, N5V 1S2
Tel: (519) 457-4041
Fax: (519) 457-4045
support-canada@diamondaircraft.com

Pos.	Detailed description / Size of Damage	Classification	Reference to attached Pictures	Proposed Repair

Date:		Stamp, Signature:		Page of
Revision:				