

TECHNISCHE INFORMATION NR. SI 36-129/1

Ersetzt SI 36-129

SERVICE INFORMATION NO. SI 36-129/1

Supersedes SI 36-129

I. TECHNISCHE ANGABEN

1.1 Betroffene Flugzeuge:

Alle HK 36 TC Flugzeuge mit ROTAX 912 S Motor.

1.2 Gegenstand

BRP-Rotax GmbH & Co KG Service Bulletin SB-912-079 R1

ATA-Code: 72-00

1.3 Anlass

BRP-Rotax GmbH & Co KG hat das Service Bulletin Nr. SB-912-079 R1 herausgegeben, in dem die Einhaltung wesentlicher Informationen zu Einbau, Betrieb und Wartung von ROTAX 912 S Motoren sehr empfohlen wird.

1.4 Information

Detaillierte technische Informationen finden Sie in BRP-Rotax GmbH & Co KG Service Bulletin SB-912-079 R1. The Betriebs- und Wartungsanforderungen gelten zusammen mit dem Flughandbuch und dem Wartungshandbuch.

II. SONSTIGES

1. Das BRP-Rotax GmbH & Co KG Service Bulletin SB-912-079 R1 ist dieser Service Information beigelegt.
2. Im Zweifelsfall kontaktieren Sie bitte BRP-Rotax GmbH & Co KG.
3. Ausführliche Informationen über das System für Technische Informationen finden Sie in der aktuellen Ausgabe der SI 36-001.

I. TECHNICAL DETAILS

1.1 Airplanes affected:

All HK 36 TC airplanes with ROTAX 912 S installed.

1.2 Subject

BRP-Rotax GmbH & Co KG Service Bulletin SB-912-079 R1

ATA-Code: 72-00

1.3 Reason

BRP-Rotax GmbH & Co KG has issued Service Bulletin No. SB-912-079 R1 highly recommends to comply with essential information regarding engine installation, operation, and maintenance of ROTAX 912 S engines.

1.4 Information

For detailed technical information refer to BRP-Rotax GmbH & Co KG Service Bulletin SB-912-079 R1. The operator and maintenance requirements apply together with the Airplane Flight Manual and the Airplane Maintenance Manual.

II. OTHERS

1. BRP-Rotax GmbH & Co KG Service Bulletin SB-912-079 R1 is attached to this Service Information.
2. In case of doubt contact BRP-Rotax GmbH & Co KG.
3. For detailed information of the Service Information System refer to SI 36-001 latest issue.

SERVICE BULLETIN

Essential information regarding engine installation, operation, and maintenance for ROTAX® 912 (Series) Aircraft Engines

ATA System: 72-00-00 Engine

**HIGHLY
RECOMMENDED***

*Failing to comply with the instructions of this SB may result in improper operation of the engine.

1) Planning information

To obtain satisfactory results, procedures specified in this publication must be accomplished with accepted methods in accordance with prevailing legal regulations.

BRP-Rotax GmbH & Co KG cannot accept any responsibility for the quality of work performed in accomplishing the requirements of this publication.

1.1) Applicability

All versions of ROTAX® engine types:

Engine type	Serial number
912 S (Series)	all

1.2) Concurrent ASB/SB/SI and SL

In addition to this Service Bulletin / Service Letter / Service Instruction the following documents must be observed and complied with:

- SI-912-016 / SI-914-019, "Selection of suitable operating fluids for ROTAX® Engine Type 912 i, 915 i, 912 and 914 (Series)".
- SL-916 i-009/915 i-011/912 i-005/912-014/914-012, Non-approved modifications or use of ROTAX® unapproved engine components or accessories for ROTAX® Aircraft Engines.
- SB-912-044 - Use of the ROTAX® supplied airbox for all ROTAX® Engine Types 912 A/F (Series).
- SI-03-1998 - Engine start at low temperatures at ROTAX® Engine Type 912 and 914 (Series).
- in general, all relevant Alert Service Bulletins (ASB), Service Bulletins (SB), Service Instructions (SI), Service Letters (SL), Service Instruction - Parts and Accessories (SI-PAC) with relevance to perform this maintenance, repair or overhaul task.

1.3) Reason

Field observations that are carried out as part of our obligations revealed an increased number of unexplainable engine power losses, engine vibrations, and piston damage. In-depth investigations on various aircraft models have identified the main contributing factors and causes for the majority of these occurrences. The findings and insights of these investigations are hereby shared with all stakeholders. It is also pointed out that these guidelines and requirements must be observed.

1.4) Subject

Essential information regarding engine installation, operation, and maintenance for ROTAX® 912 (Series) Aircraft Engines.

d07179.fm

SERVICE BULLETIN

1.5) Compliance

A significant part of the SB's content is related to existing requirements that are already in place and described in the currently valid Instructions for Continued Airworthiness (ICA) documents. The purpose of these requirements within the SB is to emphasize that these specifications must be complied with. The content of the SB must therefore be analyzed, understood and checked for compliance by all stakeholders.

In case of non-compliances, corrective actions must be implemented by the associated stakeholder to comply with the existing requirements.

OEM / TC-holder requirements:

- Check for compliance with applicable guidelines and requirements in your area of accountability as soon as possible and correct any non-compliance at the next possible occasion.
- Any additional specifications, new requirements or limitations that are not yet available in the existing ICAs must be implemented by the corresponding stakeholder as quickly as possible but at latest 12 months after publication of this Service Bulletin.

Operators / Pilots requirements:

- Any additional specifications, new requirements or limitations that are not yet available in the existing ICAs must be observed according to the implementation of the OEM.
- Check for compliance with applicable guidelines and requirements **in your area of accountability**.

Maintenance requirements:

- Any additional specifications, new requirements or limitations that are not yet available in the existing ICAs must be observed according to the implementation of the OEM.
- These maintenance instructions must be considered at any maintenance events, retrofitting, repair and overhaul.
- Check for compliance with applicable guidelines and requirements in your area of accountability and take actions to correct the non-compliance at the next regular maintenance interval.



Non-compliance with these instructions could result in engine damages, personal injuries or death.

1.6) Approval

The technical content of this document is approved under the authority of the DOA ref. EASA.21J.048.

1.7) Labor time

Estimated labor hours:

Engine installed in the aircraft - - - labor time will depend on airframe installation and therefore no estimate is available from the engine manufacturer.

1.8) Mass data

Change of weight - - - depends on the aircraft installation and installation situation (parts chosen by the maintenance technician are not considered).

Moment of inertia - - - unaffected

d07179.fm

SERVICE BULLETIN

1.9) Electrical load data

No change.

1.10) Software modifications

No change.

1.11) References

In addition to this technical information refer to current issue of

- In general Operators Manual (OM) and in particular: Chapter 4
- In general Installation Manual (IM) and in particular: Chapter 72-60-00 and 73-00-00
- In general Maintenance Manual Line (MML) and in particular: Chapter 05-20-00
- In general Maintenance Manual Heavy (MMH) and in particular: Chapter 24-20-00, 73-00-00, 74-00-00 and 78-00-00

NOTE: The status of the Manuals can be determined by checking the table of amendments. The 1st column of this table shows the revision status. Compare this number to the one listed on the ROTAX® website:

www.flyrotax.com. Updates and current revisions can be downloaded for free.

1.12) Other Publications affected

None.

SERVICE BULLETIN

2) Material Information

None.

3) Accomplishment/Instructions

- ROTAX® reserves the right to make any amendments to existing documents, which might become necessary due to this standardization, at the time of next revision or issue.

NOTE: Before maintenance, review the entire documentation to make sure you have a complete understanding of the procedure and requirements.

Accomplishment

All measures must be implemented and confirmed by at least one of the following persons or organizations:

OEM requirements:

- Aircraft OEM.

Operator requirements:

- Aircraft operator, pilot, student.

Maintenance requirements:

- Persons with approved qualifications for the corresponding engine types. Only authorized persons (iRMT, Level Line / Heavy Maintenance) are entitled to carry out this work.
- ROTAX® - Authorized Distributors or their independent Service Centers.
- ROTAX® - Airworthiness representatives.
- Persons approved by the respective Aviation Authorities.

NOTE: Indicates supplementary information which may be needed to fully complete or understand an instruction.



All work has to be performed in accordance with the relevant ROTAX® Instructions for Continued Airworthiness (ICA) of the respective engine type.

General

Further material on general inspection, maintenance and repair can also be found in relevant Advisory Circular AC 43.13 from FAA.

Advisory Circular

This Manual "Advisory Circular" AC describes maintenance methods, techniques and practice. These are recognized and authorized for inspection and repairs in non-pressurized areas for which there are no separate maintenance and repair instructions.

SERVICE BULLETIN

3.1) Introduction

The identified main contributing factors and causes for the aforementioned occurrences have been listed below. Each contributing factor and cause is subsequently detailed in the respective subsection following a common structure:

- Background information
- OEM requirements
- Operator requirements
- Maintenance requirements

Table of contents:

Chapter	Description	Page
3.2	Fuel system	6
3.3	Exhaust back pressure	9
3.4	Engine power setting	11
3.5	Engine load	15
3.6	Intake air heat up - Carb. heat bypass, Airbox temperature, Engine compartment ventilation	16
3.7	Carburetor heat - Usage, Temperature increase	18
3.8	Coolant temperature (CT)	19
3.9	Fuel type and quality	20
3.10	Ignition system - Easy-start activation, Trigger coil gap, Temp. influence	22
3.11	Spark plugs	25
3.12	Exhaust gas CO measurement	27
3.13	Ambient conditions	28
3.14	Instrumentation	29
3.15	Idle speed setting	30
3.16	Engine starting and shutdown procedure and tips	31
3.17	Differential & crankcase pressure check	33
3.18	Selection of pistons and cylinders	34

d07179.fm

SERVICE BULLETIN

3.2) Fuel system

3.2.1) Background information

Requirements of the fuel system:

The fuel system is a complex and important subsystem of an aircraft engine installation. The fuel system must be designed to ensure that the engine is supplied with sufficient fuel at the correct pressure in every operational situation. Any deviation from the installation manual and maintenance manual may result in a non-standard operation.

Carburetor synchronization and maintenance:

Regular synchronization of the carburetors greatly improves smoothness of engine operation.

Air-to-fuel ratio:

The air-to-fuel ratio (mixture) heavily influences the whole combustion process. Especially lean conditions may have negative effects and can be caused by various factors. Several occurrences of vibrations and power losses have been identified to be caused by restricted fuel supply (e.g. contamination, vapor lock, etc.) and/or inadequate ventilation of the carburetors (e.g. blocked, inadequately routed venting lines).

3.2.2) OEM requirements

Requirements of the fuel system:

Make sure to comply with the fuel system requirements outlined in the installation manual in particular:

Fuel flow:	min. 35 l/h (9.25 gal/h).
Fuel pressure: (relative to ambient pressure)	0.15 - 0.5 bar (2.18 - 7.25 psi)
Fuel lines:	Inlet line inner diameter: min. 7.5 mm (0.3 in.) (AN-6 or 3/8").

NOTE: Due to the technical design and installation conditions (construction of the return line, etc.) pressure fluctuations at the fuel pump are possible. These pressure fluctuations within the specified operating limits are not considered a problem.

Low fuel pressure indications are also possible and allowed, but the pressure must stabilize to the operating limit within 10 seconds. However, low pressure indications below 0.08 bar (1.16 psi) may only last a maximum of 1 second. If not, the cause must be determined and rectified.

- It is also advisable to route the fuel line as far away from heat source as possible and to add thermal isolation around the fuel lines, especially within the engine compartment.
- The electrical fuel pump must be positioned in order to be gravity fed from the fuel (catch) tank and the hoses between the electrical fuel pump and fuel tank must be self bleeding (No airtrap).
- Fuel line should also be routed with sufficient bending radius (Follow manufacturer recommendation) in order to prevent the pipe from kinking.
- In order to reduce the pressure drop along the fuel line, the use of sharp angled adapters or banjo connectors should be avoided as much as possible.
- The fuel hose on the suction side must be collapse resistant.

SERVICE BULLETIN

- All the fuel hoses must also be sufficiently supported in order to avoid excessive vibration of the hose, which would increase the risk of vapor lock.
- When installing other "devices" than the one specified in the Rotax installation manual on the suction side of the fuel pump, their effect on the fuel system pressure drop must be carefully investigated at all operating conditions.
- Use appropriate fuel filter (coarse/fine) and water separator/gascolator.
- For prevention of vapor locks: The length of the fuel line on the suction side of the electrical / mechanical fuel pump (between the fuel tank and the fuel pump) must be kept as short as possible to minimize vapor formation at high altitudes and high temperatures. High engine compartment temperatures increase fuel temperature and therefore facilitate vapor formation of the fuel.
- Fuel temperature: The fuel system must be designed considering vapor lock depending on the ambient conditions (e.g. pressure and temperature) and the used fuel types (vapor pressure class). Should problems occur during the test period, the affected components, e.g. the supply line to the fuel pumps, must be cooled. To avoid too much fuel heating at the fuel pump inlet, it is obligatory to route the fuel return line from the engine to the main fuel tank, and not to the electrical fuel pump inlet or header tank, see latest Installation Manual (IM), Chapter 73-00-00.
- Install check valves with appropriate specification (e.g. with sufficient cross section, opening pressure etc.) parallel to the electrical fuel pumps as indicated in the latest Installation Manual (IM), Chapter 73-00-00.
- Venting lines: The carburetor float chamber venting lines have to be routed into a ram-air and vacuum free zone or into the GENUINE ROTAX® airbox, according to the requirements and release of BRP-Rotax GmbH & Co KG. These lines must not be routed into the slipstream. If the drainage lines of the airbox are connected with the drainage lines of the drip trays or the carburetors by a T-piece, these lines must not be routed down the firewall (drainage lines of the airbox separately are allowed).
- At first installation or when doing extensive work on the fuel system or replacing fuel line, the complete fuel system should be flushed in order to remove all potential contaminant.

Carburetor synchronization and maintenance:

- Ensure proper synchronization at aircraft delivery to factor the influence of the aircraft engine installation into the air feed to the carburetor.

Air-to-fuel ratio:

- Use appropriate ROTAX® genuine air filter.
- Make sure to use appropriate carburetor jets (idle, main, needle) to factor the influence of the aircraft engine installation into the air/fuel ratio. For more information see current version of: Maintenance Manual Heavy (MMH), Chapter 73-00-10, page 16.

SB-912-044 - Use of the ROTAX® supplied airbox for all ROTAX® Engine Types 912 A/F (Series).

SI-03-1998 - Engine start at low temperatures at ROTAX® Engine Type 912 and 914 (Series).

- Ensure adequate fuel delivery in accordance with the fuel system requirements in the latest Installation Manual (IM) of the respective engine type.
- Use ROTAX® genuine airbox (optional).

d07179.fm

SERVICE BULLETIN

- Install venting lines in accordance with the latest Installation Manual (IM) of the respective engine type.
- Do not install non-approved mixture leaning devices.

3.2.3) Operator requirements

None.

3.2.4) Maintenance requirements

Requirements of the fuel system:

Make sure to maintain the fuel system in accordance with the relevant engine and aircraft maintenance manuals and applicable instruction for continued airworthiness. In particular fuel lines, fuel filter (coarse/fine) and water separator/gascolator, and venting lines must be kept in proper working order.

At first installation or when doing extensive work on the fuel system or replacing fuel line, the complete fuel system should be flushed in order to remove all potential contaminant.

Carburetor synchronization and maintenance:

Make sure to regularly inspect and maintain the carburetors in accordance with the relevant engine maintenance manuals. In particular the synchronization of the carburetors has shown to be very effective in case of vibration.

Check that the complete system configuration is still in accordance with the applicable aircraft and engine type design. (Correct hose size and type, correct fixations, correct heat insulation,...)

Air-to-fuel ratio:

Make sure to regularly inspect and maintain in particular air filters (leakage), airboxes (disconnected pipes,...), carburetors, fuel filters (leakage, containment), check hoses and venting lines (e.g. for disconnections, leakages, no kink, porosity, disconnected line, wrongly routed line,...). These influence the air-to-fuel ratio drastically and must be kept in proper working order.

SERVICE BULLETIN

3.3) Exhaust back pressure

3.3.1) Background information

Exhaust back pressure beyond the stated limits can lead to an increased risk of engine damage (in particular: piston damage) and engine stoppage.

Non-approved modification of Genuine ROTAX® exhaust system components can lead to incorrect back pressure.

3.3.2) OEM requirements

The modification of ROTAX® genuine exhaust system or the use of non ROTAX® genuine exhaust system or components, requires the aircraft manufacturer to validate back pressure measurements. Exhaust systems with back pressure measurement(s) beyond the limits outlined in the latest Installation Manual (IM) of the respective engine types, must not be used with ROTAX® aircraft engines. Warranty will be denied in such cases.



See SL-916i-009/915 i-011/912 i-005/912-014/914-012, Non-approved modifications or use of ROTAX® unapproved engine components or accessories for ROTAX® Aircraft Engines

The exhaust back pressure measurement has to be performed on a serial production aircraft (not a development prototype that is subject to change). This also applies to any modifications to the exhaust system; in this case, the measurements have to be repeated and results updated.

Exhaust back pressure:	
Max.	0.2 bar (2.9 psi) at wide open throttle and 5800 engine rpm, ISA conditions, ambient pressure > 950 mbar (28.05 inHg).
Min.	0.08 (1.2 psi) bar at wide open throttle and 5800 engine rpm, ISA conditions, ambient pressure > 950 mbar (28.05 inHg).

NOTE: Suitable documentation of these back-pressure measurements have to be provided for any warranty application due to piston damage. Warranty applicants with missing documentation will be deferred to their airframe manufacturer for support.

3.3.3) Operator requirements

None.

d07179.fm

SERVICE BULLETIN

3.3.4) Maintenance requirements

Please check the exhaust system while performing maintenance events.

Pay special attention to:

- Any unauthorized modifications or improper repairs on the exhaust system.
- Damages and cracks due to mechanical impact, e.g. heavy landing.
- When performing repairs to the exhaust system, avoid e.g. excessive welding seams, introducing kinks, or any other modifications which might limit the available cross-section of the exhaust system (thus increasing exhaust back-pressure).

SERVICE BULLETIN

3.4) Engine power setting

3.4.1) Background information

Manifold absolute pressure (MAP) and engine speed (in RPM) are vital parameters when controlling engine power and the combustion process. The combination of these aforementioned parameters strongly influences the internal stress (e.g. internal cylinder pressure) on the engine and therefore the margin/robustness of engines for piston damage / pre-ignition and/or detonation. There are several measures to increase the margin/robustness for piston damage / pre-ignition and/or detonation. The correct operation of the engine by the pilot (e.g. power setting and power adjustments) is of paramount importance.

NOTE: Beside the combination of engine control parameters the type and quality of fuel has the most individual influence on piston damage/pre-ignition.

3.4.2) OEM requirements

- Install MAP gauge to be able to set appropriate engine power (MAP & RPM) and allow proper monitoring of engine operation - even for aircraft equipped with fixed-pitch propellers.
- For fixed-pitch propeller application alternatively a MAP gauge is not required if it can be ensured that critical MAP pressures cannot be reached. Proper fuel quality and propeller selection may be required. Manifold absolute pressure (MAP) and engine speed settings must stay within the limits as shown in Fig. 1, 2 and 3 of this Service Bulletin.
- Install suitable propellers and governors for constant-speed propellers to achieve appropriate MAP and RPM settings in accordance with this service bulletin and the latest operators manual e.g. do not install fixed-pitch propellers that cannot achieve RPM limits required for wide open throttle condition - if done anyhow make sure to provide appropriate procedure to set engine power and when required demand high-octane fuel.
- Establish correct procedures to set and make adjustments to engine power (MAP & RPM) with respect to limits and recommendations in accordance with this service bulletin and the latest operators manual.
- Establish correct procedures and/or mandate high-octane fuel when power settings (MAP & RPM) would be outside the limits and recommendations in accordance with this service bulletin and the latest operators manual.
- Implement the aforementioned procedures in your aircraft flight manual/pilot operating handbook. Power settings as per aircraft flight manual/pilot operating handbook must be within ROTAX® performance and manifold data in relation to the provided graphs.

NOTE: If in doubt use higher octane fuels. Recommend minimum RON 98 fuel in Aircraft Flight Manual (AFM) / Pilot Operating Handbook (POH) for high load applications (See section [3.5.1](#)).

SERVICE BULLETIN

3.4.3) Operator requirements

In case of an aircraft equipped with a MAP gauge by the OEM (requirement described in section 3.4.2) use the following graph to determine appropriate MAP and RPM settings depending on fuel type to ensure maximum margin/robustness for piston damage/pre-ignitions.

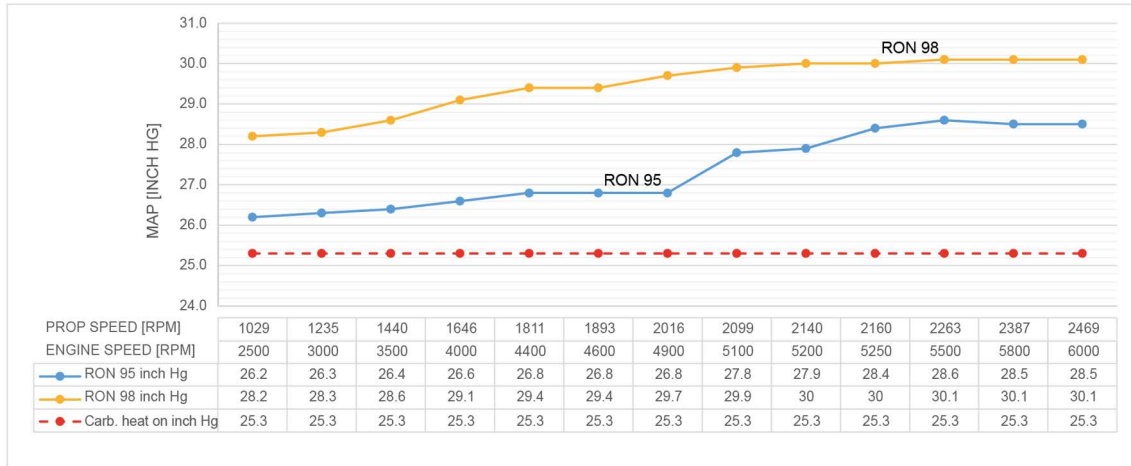

AE_2_0589

Fig. 1
 Manifold absolute pressure (MAP) and engine speed settings for ROTAX® 912 S/ULS
 for fuel type RON 95 and RON 98*

The red line labeled “carb. heat on inch Hg” represents the limits for both RON 95 and RON 98* above which piston damage may occur when the carb. heat is on/activated.



The area above the carb. heat on inch Hg line must be avoided at all times when the carb. heat is on/activated.

The blue and orange lines represent the limits for RON 95 and RON 98 respectively above which piston damage may occur. The areas above the RON 95 inch Hg line and the RON 98 inch Hg line respectively must be avoided at all times. RON 95 and RON 98 lines are valid for manifold air temperature up to max. 50 °C / 122 °F.

*for specification of fuel types see Service Instruction SI-912-016 / SI-914-019 / SI-912 i-001 / SI-915 i-001 / SI-916 i-001, “Selection of suitable operating fluids for ROTAX® Engine Type 916 i (Series), 915 i (Series), 912 i (Series), 912 and 914 (Series)”.

d07179.fm

SERVICE BULLETIN

In addition to the manifold absolute pressure and engine/propeller speed limitations, adjustment of the power needs to be performed in a correct way:

- Power increase needs to be led with the propeller control followed by the throttle control as outlined in the table below.

Step	Procedure - Power increase
1	First increase propeller speed [rpm].
2	Then increase MAP with the throttle lever.



Red arrows describe the way it should not be done. Green arrows describe the right way

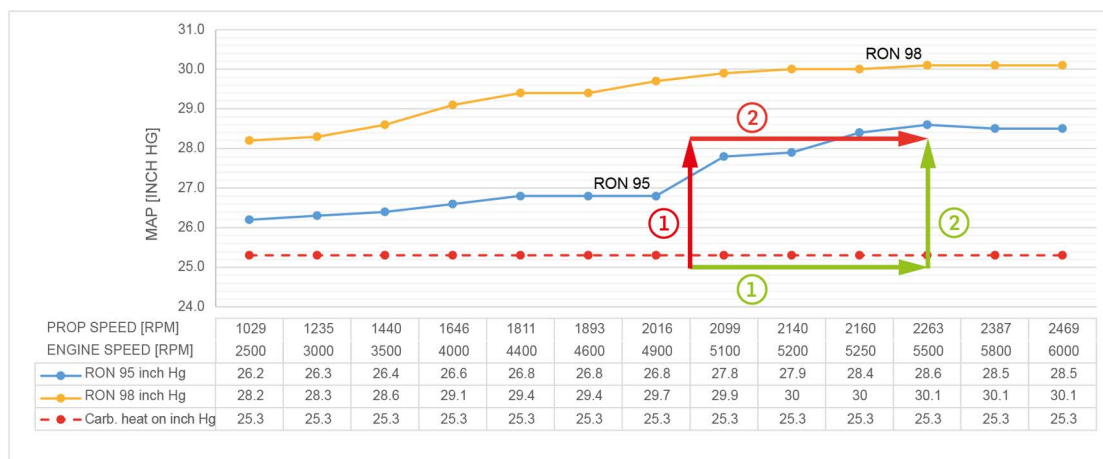

AE_2_0590_a

Fig. 2
Power increase

d07179.fm

SERVICE BULLETIN

- Power reduction needs to be led with the throttle control followed by the propeller control as outlined in the table below.

Step	Procedure - Power reduction
1	First reduce MAP with the throttle.
2	Then decrease propeller speed (rpm).



Red arrows describe the way it should not be done. Green arrows describe the right way

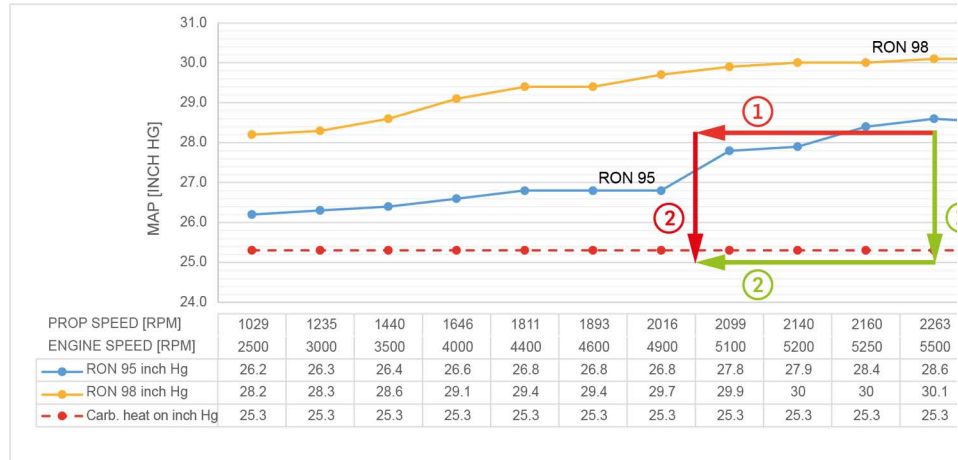

Fig. 3
Power reduction

3.4.4) Maintenance requirements

Make sure to adjust ground adjustable fixed-pitch and constant-speed propellers in accordance with the latest applicable maintenance manual and assure sufficient high engine/propeller RPM at take-off power.

3.5) Engine load

3.5.1) Background information

Depending on the usage of the aircraft, the engine may be exposed to different load patterns. The following points are considered as high load applications:

- High drag or heavy aircraft such as float-planes and amphibious aircraft.
- Glider towing (as there are repeated climbs with high load).
- Flight school operation as the following situations might occur on a regular basis:
High load due to frequency of starts and touch-and-go's.

Errors of students in stress situations like e.g. violation of allowed operating envelope, improper use of carb heat and propeller pitch.

Simulated engine failure on twin engine applications.

Training of emergency procedures.

NOTE: Using minimum RON 98 fuel provides excellent contribution to minimizing the probability of piston damages, especially in high load applications.

NOTE: Fixed pitch propellers manufactured with too much pitch, ground adjustable propellers configured with too much pitch and incorrectly controlled in-flight adjustable propellers may cause overload of the engine. Please refer to section 3.4) for ROTAX® performance and manifold data charts.

Performance recommendations:

- Restrict engine speed over 5500 rpm to 5 min maximum (as detailed in the Operators Manual (OM) 912 Series).
- Choose manifold absolute pressure (MAP) and engine RPM according to the selected fuel (refer to section 3.4.3)).
- Choose manifold absolute pressure (MAP) and engine RPM with respect to the carb. heat activation (refer section to 3.4.3)).

3.5.2) OEM requirements

If in doubt, use higher octane fuels. Recommend minimum RON 98 fuel in Aircraft Flight Manual (AFM) / Pilot Operating Handbook (POH) for high load applications.

3.5.3) Operator requirements

In case of high engine load applications opt for minimum RON 98 fuels.

3.5.4) Maintenance requirements

None.

SERVICE BULLETIN

3.6) Intake air heat up - Carb. heat bypass, Airbox temperature, Engine compartment ventilation

3.6.1) Background information

The air intake system is determined essentially by the demands of engine and of the acceptable noise emission on the intake side. An airbox can be supplied by ROTAX® as an option.

NOTE: Non-approved modification of Genuine ROTAX® airbox components can lead to negative effects on engine operation like vibrations and power losses (see as well section 3.2)).

Low (cold) air temperature in the airbox is favorable for engine performance and reduces piston damage / pre-ignition and/or detonation tendency at combustion.

Hot air conditions favor piston damage / pre-ignition and/or detonation effects. Such conditions could be caused by:

- Fresh air intake receiving hot air (e.g. leakage of carburetor heat duct - see as well section 3.7)).
- Incorrect use of carburetor heat (see as well section 3.7)).
- Inadequate engine installation, leading to excessive heat up of intake air.
- Improper maintenance or improper adjustment of the whole carburetor heat mechanism can lead to inadvertent activation of the carburetor heat system (flap not fully closed, Bowden cable not adjusted, bypass due to worn mechanism, engine movement inadvertently triggering the carburetor heat actuation mechanism).
- Inadequate engine compartment ventilation.

NOTE: Any changes on the air intake system (e.g. modification on the airbox etc.) can affect the flow rate in the air intake system and fuel mixture ratio. In the course of certification the fuel mixture process must be proofed by a CO-measurement (see as well section 3.13)).

NOTE: The engine installation will greatly affect certain aspects such as, intake air temperature, fuel mixture and operating temperatures. For proper instruction see latest Installation Manual (IM).

3.6.2) OEM requirements

Make sure to comply with the air intake system requirements outlined in the latest Installation Manual (IM) for the respective engine type, in particular:

Intake Air Ducting:

Max. length of ducting:	500 mm (19.68 in.)
Inside diameter:	Min. outside dia. of the intake socket on airbox.
Min. mean bending radius:	100mm (3.94 in.)
Air intake heat up (without carb heat):	max. 8°C (14.4°F) delta temperature at WOT 5800rpm, ambient pressure > 950 mbar(28.05 inHg).

NOTE: Air intake Heat up = Air temperature measured in the airbox - Ambient temperature

d07179.fm

SERVICE BULLETIN

ROTAX® strongly recommends additional to minimum required instrumentation the installation as per latest Installation Manual (IM) of:

- An airbox temperature sensor (see as well section [3.14.2](#)).

NOTE: This does offer the possibility to constantly monitor the MAT temperature and eventually identify issues (leaking carb heat, disconnected intake pipes,...) before they will eventually result into engine damage.

Air Filter:

High engine performance requires air temperature as low as possible at air intake. Therefore the air filter should be located in a recess of the engine cowling or separated from warm air by baffles such that fresh air can be aspirated.

- Minimize heat up of intake air (without activated carburetor heat) under cowling by proper firewall forward design and engine installation (e.g. routing of air hoses away from hot engine parts and add heat insulation where needed). Inadequate installation could cause exceeding of limits of operation (e.g. CT and EGT) and thus lead to a higher possibility of engine damage.

NOTE: Proper installations are able to achieve less than 8° C (delta between carburetor entrance and ambient temperature) at max. continuous power.

- In case of using a non-ROTAX® genuine airbox, consider the negative effect on mixture distribution. The carburetor float chamber venting lines have to be routed into a ram-air and vacuum free zone.
- Avoid improper cowling design that supplies hot air to the engine and/or restricts airflow causing inadequate cooling.
- Make sure that the air intake tubes of the airbox for fresh air and preheated air are connected correctly.
- Respect maximum allowable temperatures of engine components in all operating conditions of flight to avoid operational problems. Always design engine installations to respect all parameters and limitations.

NOTE: Suitable documentation of airbox temperature measurements will be required in case of warranty application due to piston damage.

3.6.3) Operator requirements

- Check at preflight check for any restrictions in air intake.
- Follow the OEM's instructions in Aircraft Flight Manual (AFM) / Pilot Operating Handbook (POH) with regards to airbox temperature (if proper instrument is installed), see as well section [3.7](#).

3.6.4) Maintenance requirements

- Check for modifications and restrictions in air intake and for improper connected or disconnected air intake or airbox hoses.
- Visual check of airbox for restrictions, leakages, cracks and improper connections.
- Ensure proper actuation of carb heat system (e.g. proper adjusted Bowden cable and flap). Carburetor heat flap must be fully closed when carb heat is off.
- Verify the correct actuation of the airbox push/pull mechanical linkage, no wear is allowed.
- Check for unauthorized modifications to the air intake.

d07179.fm

3.7) Carburetor heat - Usage, Temperature increase

3.7.1) Background information

Elevated air intake temperatures can contribute to piston damage, especially in combination with high engine loads. Particularly, when the carburetor heat system is activated along with high engine power settings e.g. during touch-and-go with carburetor heat on.

Field experience has shown that:

- Depending on the specific implementation of the carburetor heat system the amount of temperature rise of the intake air can be significantly above legal requirements and the operating limits.
- The misuse of carburetor heat (e.g. activated carb. heat during touch and go's) may result in piston damage / pre-ignition and/or detonation and consequently damages in the engine (piston/cylinders), loss of power and vibrations.

3.7.2) OEM requirements

- Design of carburetor heat system to exceed the actual (certification) requirements as minimal as possible (ROTAX® recommends a temperature delta of max. 20 °C / 36 °F above the minimum certification requirement (See red line (Carb. heat on Inch Hg) in [Fig. 1](#)).
- Measurement of the actual temperature increase in all applicable ambient and operating conditions, see latest Operators Manual (OM).
- Design carb heat linkage to avoid mis-actuation in case of (e.g. thermal expansion, engine movement within the shock mounts, etc.) during the whole flight envelope.
- Precisely specify the carburetor heat usage and limit its duration to the necessary minimum in the aircraft flight manual/pilot operating handbook.

CAUTION

It is not permitted to partially activate the carb. heat system. The carb. heat system has to be either activated/on or deactivated/off completely. Intermediate positions of the throttle valves in the ROTAX® genuine airbox may lead to a separation of the "hot" and the "fresh" air in the airbox which consequently leads to the provision of too hot air to one carburettor and fresh unheated air to the other carburettor. This does not only affect the system's capability to prevent carburetor icing when needed but also may lead to damage of the pistons/cylinders which were supplied with too hot air.

NOTE: The procedure and limits provided in section [3.4](#)) Engine power setting have to be considered and implemented accordingly.

3.7.3) Operator requirements

- Follow the aircraft manufacturer's instructions in their Aircraft Flight Manual (AFM) / Pilot Operating Handbook (POH) with respect to carburetor heat application - see also section [3.4](#)) Engine power setting.
- Ensure to educate (unfamiliar) pilots with respect to the importance of proper usage of carburetor heat in particular in combination of high power settings (e.g. during take-off and touch and gos, etc.).

NOTE: Verify that all the operating limits are respected in all flight conditions.

3.7.4) Maintenance requirements

None.

d07179.fm

3.8) Coolant temperature (CT)

3.8.1) Background information

Diligent monitoring of coolant temperature has a significant impact on proper engine operation, in particular case of piston damage; the respective limits must be met under all operating conditions of the engine as per current Operator Manual (OM).

NOTE: For information on engines with suffix 01, see Service Bulletin SB-912-066, current version.

In-depth investigations on various aircraft models showed better performance of the engine, also in term of longevity, with coolant temperature in the "normal" range of temperature between 80°C and 110°C (176°F and 230°F) Coolant Temperature (CT).

3.8.2) OEM requirements

Proper engine installation must meet all requirements within the latest Installation Manual (IM) and operating conditions as per latest Operator Manual (OM), including special attention to the following:

- Proper coolant system ventilation.

NOTE: In case of a thermostat installed, please follow the manufacturers instructions.

- Check temperatures, including cylinder wall temperatures at first installation.

NOTE: Suitable documentation of these cylinder wall temperatures measurements have to be provided in case of warranty application due to piston damage.

NOTE: Normal operative range between 80°C and 110°C (176°F and 230°F) Coolant Temperature (CT).

- Ensure limits are obeyed in all operating environments (different climates, hot day conditions).

3.8.3) Operator requirements

- Check for normal coolant temperature.
- Follow procedures of preflight check (coolant levels, blocked radiator).
- Consider partially covered radiator for winter.
- Follow the instructions in the Aircraft Flight Manual (AFM) / Pilot Operating Handbook (POH) for operation in different climates.

3.8.4) Maintenance requirements

Prevent insufficient cooling capacity (e.g. low coolant level, semi blocked radiator for winter, coolant pressure loss, improper coolant type).

- Check for proper function of cap of expansion tank.
- Check for proper venting of overflow bottle.
- Verify the correct purging of the coolant system in accordance with OEM's AMM instructions.
- Verify the Coolant Temperature (CT) limits reached in the last flights.

3.9) Fuel type and quality

3.9.1) Background information

Service Instruction SI-912-016 / SI-914-019 / SI-912 i-001 / SI-915 i-001 / SI-916 i-001, "Selection of suitable operating fluids for ROTAX® Engine Type 916 i (Series), 915 i (Series), 912 i (Series), 912 and 914 (Series)" shows the generally approved fuels.

Several other factors need to be considered during the process of fuel selection:

- Prevailing ambient conditions (pressure and temperature, depending on location and climate zone of usage, see section [3.3.1](#)).
- Engine operation in applications with potential high engine loads (e.g. glider towing, flight schools, float-planes & amphibious aircraft).
- Probability of pilot errors during operating; (e.g. incorrect application of propeller pitch or carburetor heat by inexperienced students in flight school applications).

NOTE: In general, improved fuel quality with minimum RON 98 fuels can mitigate other factors with increased probability of piston damage and increases engine longevity and safety margin. The selection of proper fuels is one of the main levers to prevent piston damage, especially in the case of other contributing factors being present (see the table in section [3.1](#)).

Independent of the chosen fuel the following topics are also crucial:

- Clean fuel (consider filtering/screening while fueling).
- No contaminants (water, alcohol, oil, diesel, fuel additives).
- Appropriate storage (duration, approved container).
- If available select summer / winter blends according to the relevant season (using remaining winter blend in tank during warmer temperatures increases the risk of vapor formation).
- Source, transport, storage, and refueling (equipment, environment, etc.) must be considered.

3.9.2) OEM requirements

For specifying the approved fuel types for the aircraft in the respective Aircraft Flight Manual (AFM) / Pilot Operating Handbook (POH) or equivalent, please refer to SI-912-016 / SI-914-019 / SI-912 i-001 / SI-915 i-001 / SI-916 i-001, "Selection of suitable operating fluids for ROTAX® Engine Type 916 i (Series), 915 i (Series), 912 i (Series), 912 and 914 (Series)", current version, for general recommendations.

NOTE: As outlined in section [3.9.1](#), please pay special attention to additional factors to support engine longevity and safety margin. In case of uncertainties or doubts, use minimum RON 98 fuels.

3.9.3) Operator requirements

Please follow recommendations with regards to approved fuel types as per Aircraft Flight Manual (AFM) / Pilot Operating Handbook (POH). In case of contradiction or doubts opt for minimum RON 98 fuels.

- Avoid any contamination of fuel by e.g. water, oil or diesel.
- Refrain from using fuels which exceed specified Alcohol content > 10% (E10+).
- Refrain from using non-approved fuel additives.

d07179.fm

SERVICE BULLETIN

- Ensure that the fuel source (airport/landing strip, automotive fuel station) meets the required quality standards. It is recommended to use the fuel available at the respective airport or landing strip rather than to get fuel supplied from a local automotive fuel station not knowing the quality of fuel source.

NOTE: Implement procedures to regularly check, track and document the quality of the fuel used. In case of piston damages, it is mandatory to provide a fuel sample of the fuel being used during the time of incident.

3.9.4) Maintenance requirements

- Check for signs of contaminated fuel (oil, diesel, fuel additives).
- In case of piston damages events, ensure the required fuel samples can be provided to the authorized distributor for any warranty application.
- In case of the combination of lower octane fuels and evidence of contributing factors (see section [3.1](#)) please advise the operator to change over to minimum RON 98 fuels.

SERVICE BULLETIN

3.10) Ignition system - Easy-start activation, Trigger coil gap, Temp. influence

3.10.1) Background information

The ROTAX® engines of 912 Series are equipped with a breakerless dual ignition system (DCDI-Dual Capacitor Discharge Ignition). The ignition unit needs no external power supply. Each of the two independent charging coils located on the generator stator supplies one of two ignition circuits. The energy is stored in capacitors of the SMD-electronic modules. At the moment of ignition, 2 each of the 4 external trigger coils actuate the discharge of the capacitors via the primary circuit of the double ignition coil assy.

Additionally, an Advanced Start Module (ASM) System has been introduced with ignition module 966727 and later and flywheel hub 966872 and later. The Advanced Start Module System enables the optional easy-start function. In order to use the easy-start function the relevant connections to the starter relay (1) and ignition switch (2) need to be made (see fig.4).

The system is designed so that the ignition timing is automatically set to 3° after the piston's top dead center (TDC) during engine start-up between 650 to 1000 engine RPM. Consequently the ignition timing is automatically changed to 26° before the piston's top dead center above the 650 to 1000 engine RPM.

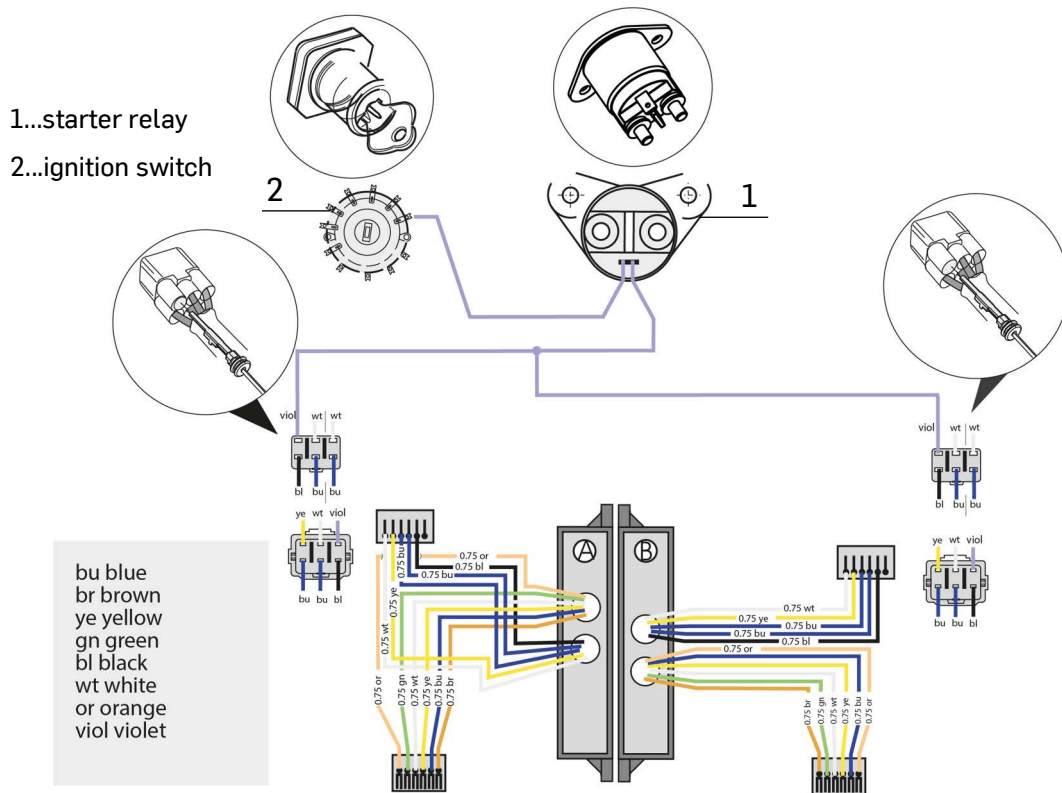

d07179.fm

SERVICE BULLETIN

The easy-start function can be used for aircraft, which have an engine start problem in cold conditions.

NOTE: For more detailed information about the Advanced Start Module (ASM) see SI-912-028. Analysis of field observations so far have not revealed a malfunction of the Advanced Start Module (ASM) as a root cause, but pointed mainly to the fuel system and/or fuel type and quality.

Respecting the limits below the ignition system is essentially single fault tolerant:

- High temperatures in the engine compartment.

NOTE: The trigger coils as all other ignition electrics must not be exposed to ambient temperatures higher than 80 °C (176 °F) - see latest Maintenance Manual Heavy (MMH), Chapter 24-20-00, page 6.

- Gap of trigger coils (IH02), see [Fig. 5](#).

NOTE: Due to the operating principle of the ignition system the gap of the trigger coil has to be within limits - see latest Maintenance Manual Heavy (MMH), Chapter 24-20-00, page 16.

Intentional activation of the easy-start function is only possible when a minimum voltage of 2.8 V is applied at the advanced start terminals and they must therefore be grounded when not intended to be activated.

3.10.2) OEM requirements

- Ensure proper ventilation of the engine compartment to avoid excess temperatures and heat soak.
- Do not power the advanced start terminal except when the activation of the easy-start is intended.
- Ensure that the connection to the advanced start terminal (ignition modules 6-pin connectors) is grounded when the engine is running to prevent any inadvertent activation of the easy-start function.
- Do not connect the signal wire directly to the electric starter motor - as the circuit does not have voltage protection.
- Ensure that the trigger coil gap are not inadvertently changed (e.g. collision with other parts during installation). The trigger coils have to be within the limits, see latest Maintenance Manual Heavy (MMH) Chapter 24-20-00.

NOTICE

Field observation has shown that some trigger gaps were above specified limits. The trigger coil gap is factory preset and within normal usage there is no need to adjust it.

- Ensure that the engine installation is performed in accordance with the latest installation manual e.g. grounding of the trigger coil wire and the ignition switch shielding is done correctly.

3.10.3) Operator requirements

Do not attempt to intentionally activate the easy-start function except when starting the engine.

SERVICE BULLETIN

3.10.4) Maintenance requirements

- Check the wiring of the ignition system and make sure that the grounding of the trigger coil wire and the ignition switch shielding is done correctly.
- Ensure that the trigger coil gaps are not inadvertently changed (e.g. collision with other parts during installation). The trigger coils have to be within the limits, see latest Maintenance Manual Heavy (MMH) Chapter 24-20-00.

NOTICE

Field observation has shown that some trigger gaps were above specified limits. The trigger coil gap is factory preset and within normal usage there is no need to adjust it.

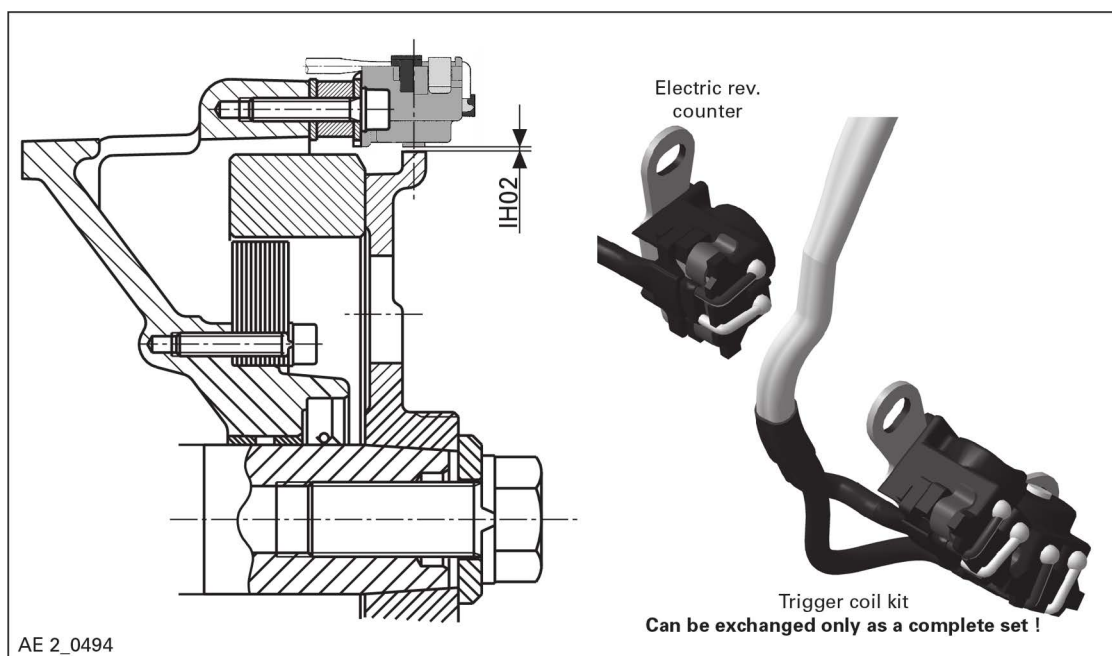

Fig. 5

SERVICE BULLETIN

3.11) Spark plugs

3.11.1) Background information

The spark plugs provide the spark to the combustion chamber via the ignition voltage generated by four double ignition coils which are situated above the spark plugs, connected via the high voltage ignition cable assy.

For proper combustion the correct spark plug grade / heat range and electrode gap is important.

Any deviation of these factors from the factory specification can affect the engine operation (ex. vibration, loss of power, piston damage).

3.11.2) OEM requirements

- As OEM make sure that the ROTAX® genuine spark plugs and heat conduction compound is applied only to the threads of the spark plugs.

NOTE: Do use correct quantity of heat conduction compound. Excessive use of heat conduction compound could lead to the effect of contributing to piston damage.

- In a pre-delivery inspection make sure that spark plugs / spark plug connectors and trigger coils are not damaged.

3.11.3) Operator requirements

None.

3.11.4) Maintenance requirements

- Inspect for incorrect spark plug grade / heat range and change spark plugs together with use of heat conduction compound on the spark plug threads as per latest Maintenance Manual Line (MML) of the respective engine type:

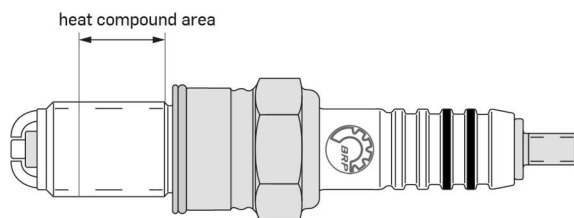

AE_2_0584

Fig. 6

NOTE: Do use correct quantity of heat conduction compound. Excessive use of heat conduction compound could lead to the effect of contributing to piston damage.

SERVICE BULLETIN

- Inspect the electrode gap as per latest Maintenance Manual Line (MML) of the respective engine type:

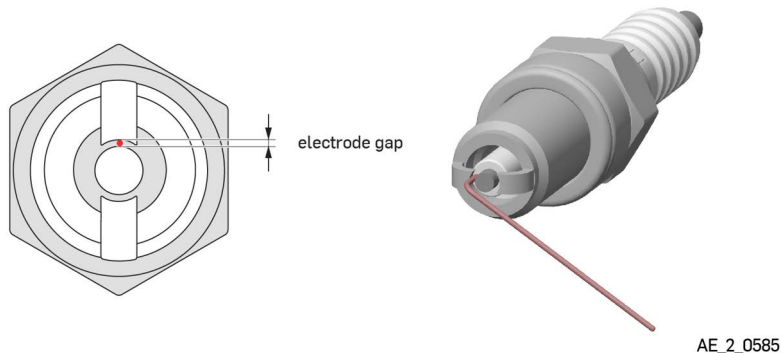

Fig. 7

NOTE: Due to the curved gap between the center electrode and the ground electrodes, it is suggested to use a wire type feeler gauge for accurate gap measurement..

Electrode gap	
New	Wear limit
0.8 - 0.9 mm (0.031 - 0.035 in.)	1.1 mm (0.043 in.)

SERVICE BULLETIN

3.12) Exhaust gas CO measurement

3.12.1) Background information

All ROTAX® aircraft engines are bench tested and have a relevant carburetor factory calibration.

As mentioned in the Installation Manual (IM), it is the responsibility of the aircraft manufacturer to carry out exhaust gas CO measurement to confirm that their installation and/ or use of non ROTAX® parts does not have a detrimental effect on carburetor calibration and is within ROTAX® stated limits.

NOTE: The test should be performed as a ground run with full load (for allowed RPM at wide open throttle please refer to section 3.4.1) with the engine cowl fixed in flight position and engine at full operating temperature.

3.12.2) OEM requirements

Perform testing at first engine installation within the limits specified in the latest Installation Manual (IM).

Engine type	CO Measurement
912 S, ULS	Min. 3 % (wide open throttle, rpm of min. 5200 must be achieved)

- Measurements are to be taken from each cylinder from the position of EGT measurement.
- Re-test at modification of the exhaust system.

3.12.3) Operator requirements

None.

3.12.4) Maintenance requirements

In case of maintenance of the exhaust system make sure to perform CO measurement according to the relevant AMM.

d07179.fm

SERVICE BULLETIN

3.13) Ambient conditions

3.13.1) Background information

The engines are operated in various areas of the world and therefore the prevailing ambient conditions (pressure and temperature) are strongly depending on location and climate zone of usage.

NOTICE

Do not operate the engine above the limits of the graph in section 3.4).

3.13.2) OEM requirements

- Check for estimated operating environments in different climates and precisely specify via Aircraft Flight Manual (AFM) / Pilot Operating Handbook (POH) to educate the operator.
- Consider the ambient conditions in the charts in the Aircraft Flight Manual (AFM) / Pilot Operating Handbook (POH) .

3.13.3) Operator requirements

Follow the instructions in the Aircraft Flight Manual (AFM) / Pilot Operating Handbook (POH) for operation in different climates.

3.13.4) Maintenance requirements

Perform correct maintenance for the specific climate according to the relevant Aircraft Maintenance Manual.

3.14) Instrumentation

3.14.1) Background information

ROTAX® strongly recommends additional to minimum required instrumentation the installation as per latest Installation Manual (IM) of:

- A manifold absolute pressure gauge.
- An airbox temperature sensor (see as well section 3.5)).

3.14.2) OEM requirements

Follow the ROTAX® recommendation to install:

- A manifold absolute pressure gauge.
- An airbox temperature sensor.

Precisely specify the use of instrumentation via Aircraft Flight Manual (AFM) / Pilot Operating Handbook (POH) to educate the operator.

3.14.3) Operator requirements

- Follow the instructions in Aircraft Flight Manual (AFM) / Pilot Operating Handbook (POH) for operation and proper reading of instrumentation and the specified limits.

3.14.4) Maintenance requirements

- Check the proper function of the instrumentation and their sensors according to the relevant Aircraft Maintenance Manual. Perform proper calibration of whole measurement chain.

3.15) Idle speed setting

3.15.1) Background information

To reach a smooth engine run the engine idle speed must be maintained as high as practical. The idle speed has to be set about 1400 to 1800 rpm. The engine start and stop behavior should be most efficient in this rpm-range.

3.15.2) OEM requirements

- The idle speed for the relevant aircraft needs to be specified via Aircraft Flight Manual (AFM) / Pilot Operating Handbook (POH) to educate the operator.
- It is strongly recommended that there is a mechanical "stop" -position on the throttle control inside the cockpit.

NOTE: This is to ensure that the throttle cannot be forced so as to bend the "stops" on the carburetors and inadvertently stop the engine or cause rough running at idle.

- Ensure proper support of the throttle actuation cable.
- Ensure that the throttle cable end support are sufficiently rigidly mounted.
- Reduce the length of cable lying outside of the guiding sleeve
- Favor the use of a push - pull installation.

3.15.3) Operator requirements

- After engine start or after landing it is recommended to advance the throttle, so that the engine runs smoother. Ground idle should be between 1400 and 2200 rpm.
- Ensure the engine is at its lowest possible idle speed (minimum of 1400 rpm) before selecting "ignition OFF".

3.15.4) Maintenance requirements

- Check the carburetors for bent "stops", which inadvertently could stop the engine or cause rough running at idle.
- Check the correct actuation of the carburetor by the power lever:
 - When the power lever is set to idle, check that the lever on the carburetor is on the idle stop
 - When the power lever is set to max Take off power, check that the lever on the carburetor is on the max power stop.
 - Check that the throttle cable is correctly supported and that its support are not loose.
 - Check that the throttle cable is securely attached at its both ends.
 - If installed, make sure that the fail safe system pushing the throttle to max power in case of actuation cable failure is functioning correctly.

SERVICE BULLETIN

3.16) Engine startup and shutdown procedure and tips

3.16.1) Background information

Field experience has shown that starting and shutting down the 912 S/ULS (Series) can be difficult, when using traditional or legacy aircraft engines techniques.

NOTE: If advanced start module is used see for detail section [3.10.1](#)).

3.16.2) OEM requirements

- Consider the relevant engine starting and shutdown procedure and tips also in the AFM / POH (pilot operating handbook) to educate the operator.

3.16.3) Operator requirements

Starting procedure and tips:

Cold engines	
Step	Procedure
1	Due to a feature of the carburetor design the throttle must be at idle (fully closed) when starting a cold engine. This allows for more effective fuel enrichment.
2	The choke must be fully opened.
3	Soon after starting advance the throttle to around 2000 rpm and slowly close the choke.
4	Keep engine at around 2200 rpm for warm up period.

Hot engines	
Step	Procedure
1	It is always prudent to park the aircraft with the nose pointing into wind to aid the cooling after shut down and prevent excessive heat soak under the engine cowling.
2	Open the throttle a small amount slowly while cranking (choke closed). Once the engine fires, advance throttle to 1800 / 2000 rpm.

Engines which have not started due to wrong procedure and are "flooded"	
Step	Procedure
1	Open throttle fully (choke closed).
2	Ignition ON and start the engine.

NOTICE

Pay attention, engine may immediately reach high rpm.

NOTE: To increase power, put the propeller governor lever to maximum rpm speed, then increase MAP with the throttle lever. Refer also to the pilot operating handbook of the aircraft manufacturer for relevant power setting.

d07179.fm

SERVICE BULLETIN

NOTE: Allow the engine to cool at idle for several minutes before turning off the engine, as follows:

Engine shutdown tips:

Step	Procedure
1	It is always prudent to park the aircraft with the nose pointing into wind to aid the cooling after shut down and prevent excessive heat soak under the engine cowling.
2	Reduce loading on the propeller and gearbox by adjusting the propeller to fine pitch (in-flight variable pitch propellers) and move throttle to idle position.
3	After cooling down run, throttle must be at idle so engine at its minimum speed, switch ignition off on one circuit for a short time (2-3 seconds) then switch off the second circuit.

NOTE: To decrease power, first reduce MAP with the throttle, and then decrease rpm with the propeller control. See also section [3.4.3](#).

3.16.4) Maintenance requirements

None.

3.17) Piston differential pressure check

3.17.1) Background information

Piston (ring) damages can often be identified before (severe) damages and subsequent effects like vibrations and power loss occur. The standard procedure to check the piston, piston rings, and intake/exhaust valves is the differential pressure check (see latest Maintenance Manual Line (MML), Chapter 12-20-00). An additional measurement (compression check for fault-tracing) has already been provided when differential pressure check readings are unclear (see latest Maintenance Manual Line (MML), Chapter 12-20-00).

3.17.2) OEM requirements

Additional crankcase pressure measurement must be implemented in the respective Maintenance Manual when applicable.

3.17.3) Operator requirements

None.

3.17.4) Maintenance requirements

The differential pressure check (see latest Maintenance Manual Line (MML), Chapter 05-20-00, section maintenance schedule) is usually required every 100 hours when more than 30% leaded fuel or every 200 hours when unleaded fuel is used. The differential pressure check should be carried out more frequently on engines under 400 hours and should not only be checked for the maximum value of 25% (e.g. from 6 to 4.5 bar (87 psi to 65 psi)) but should also consider differences between cylinders.

SERVICE BULLETIN

3.18) Selection of pistons and cylinders

3.18.1) Background information

It is required to match pistons (red/green) to cylinders (A/B) and vice versa and to check the installation clearance (CY01 /PI01) in accordance with the latest Maintenance Manual Heavy (MMH), Chapter 72-30-10, when installing pistons and/or cylinders. ROTAX® has recognized that maintenance shops or aircraft mechanics may elect to deliberately match a "small" piston ("Red") with either cylinder to provide more clearance. Unfortunately, this is ill-advised. More clearance will lead to more tilting movements that may cause damages of the pistons and cylinders.

3.18.2) OEM requirements

None.

3.18.3) Operator requirements

None.

3.18.4) Maintenance requirements

Do not deliberately match "small" pistons ("Red") with "large" ("B") cylinders to provide more clearance. Piston and cylinders have to be matched correctly:

- "Red" Piston → "A" Cylinder.
- "Green" Piston → "B" Cylinder.

Description	Code	Reading new		Wear limit	
		min.	max.	100%	50%
Cylinder "A" with "Red" piston:	CY01 /PI01	0.002 mm 0.0001 in	0.024 mm 0.0009 in	0.130 mm 0.0051 in	0.076 mm 0.0030 in
Cylinder "B" with "Green" piston:	CY01 /PI01	0.002 mm 0.0001 in	0.026 mm 0.0010 in	0.130 mm 0.0051 in	0.077 mm 0.0031 in

SERVICE BULLETIN

4) Summary

These instructions (section 3) have to be followed in accordance with the deadlines specified in section 1.5).

The execution of this Service Bulletin must be confirmed in the logbook.

NOTE: Work on EASA certified parts might affect the EASA Form 1 and does require appropriate documentation by authorized persons. Repairs must be entered into the engine logbook and also do apply for the EASA Form 1.

| A revision bar outside of the page margin indicates a change to text or graphic.

Translation into other languages might be performed in the course of language localization but does not lie within ROTAX® scope of responsibility.

In any case the original text in English language and the metric units are authoritative.

5) Inquiries

Inquiries regarding this Service Bulletin should be sent to the ROTAX® Authorized Distributor of your area.

A list of all ROTAX® Authorized Distributors or their independent Service Centers is provided on <https://dealerlocator.flyrotax.com>.