

TECHNISCHE INFORMATION NR. SI 36-074

HINWEIS: Technische Informationen werden **nur** verwendet um:
1) Informationen von DAI an unsere Kunden weiterzugeben.
2) Informationen / Dokumente von unseren Zulieferern mit zusätzlichen Informationen an unsere Kunden weiterzugeben.
Typischerweise unterstehen Technische Informationen keinem Revisionsdienst. Neue Informationen oder Änderungen derer werden durch eine neue Technische Information weitergegeben.

SERVICE INFORMATION NO. SI 36-074

NOTE: SI's are used **only**:
1) To distribute information from DAI to our customers.
2) To distribute applicable information / documents from our suppliers to our customers with additional information.
Typically there is no revision service for SI's. Each new information or change of that will be send along with a new SI.

I. TECHNISCHE ANGABEN

1.1 Betroffene Flugzeuge:

Alle HK 36 R, TS, TC, TTS, TTC und TTC-ECO Flugzeuge

1.2 Gegenstand

ATA Code: 79-20

Rotax Service Bulletin ASB 912-060 und ASB 914-043

1.3 Anlass

Rotax Service Bulletin – Kontrolle des Anzugsdrehmoments der Ölpumpenbefestigungsschrauben

I. TECHNICAL DETAILS

1.1 Airplanes affected:

All HK 36 R, TS, TC, TTS, TTC and TTC-ECO aircraft

1.2 Subject

ATA Code: 79-20

Rotax Service Bulletin ASB 912-060 and ASB 914-043

1.3 Reason

Rotax Service Bulletin – Checking of oil pump fixing bolts for correct torque

Rotax hat ein Service Bulletin für eingeschränkte Motorseriennummern veröffentlicht, welche eine Kontrolle des Anzugsdrehmoments der Ölpumpenbefestigungsschrauben vor dem nächsten Flug und bis spätestens 01-Aug-2012 vorschreibt

1.4 Information

Weitere technische Informationen sind im Rotax Service Bulletin ASB 912-060 und ASB 914-043 enthalten welche ohne weitere Ergänzungen und Einschränkungen anwendbar ist.

II. SONSTIGES

Bei etwaigen Fragen kontaktieren Sie bitte BRP-Powertrain GmbH & Co. KG.

Rotax Service Bulletin ASB 912-060 und ASB 914-043 liegen dieser Technischen Information bei.

Rotax has issued a service bulletin for certain engine serial numbers requiring an inspection of the oil pump fixing bolts for correct torque before next flight and at the latest before 01-Aug-2012.

1.4 Information

For detailed technical information refer to Rotax Service Bulletin ASB 912-060 and ASB 914-043 which is applicable without any further additions or restrictions.

II. OTHER INFORMATION

In case of doubt contact BRP-Powertrain GmbH & Co. KG

Rotax Service Bulletin ASB 912-060 and ASB 914-043 are attached to this Service Information.



ALERT SERVICE BULLETIN

CHECKING OF THE OIL PUMP FIXING BOLTS FOR CORRECT TORQUE FOR ROTAX® ENGINE TYPE 912 AND 914 (SERIES)

ASB-912-060

ASB-914-043

MANDATORY

Symbols used:

Please, pay attention to the following symbols throughout this document emphasizing particular information.

- ▲ **WARNING:** Identifies an instruction, which if not followed, may cause serious injury or even death.
- **CAUTION:** Denotes an instruction which if not followed, may severely damage the engine or could lead to suspension of warranty.
- ◆ **NOTE:** Information useful for better handling.

| || A revision bar outside of the page margin indicates a change to text or graphic.

1) Planning information

1.1) Engines affected

All versions of the engine type:

- 912 S from S/N 4,924.287 up to S/N 4,924.295 inclusive/4,924.300 up to 4,924.304 inclusive/4,924.342 up to 4,924.350 inclusive/4,924.352/4,924.353
- 914 F from S/N 4,421.079 up to S/N 4,421.081 inclusive

1.2) Concurrent ASB/SB/SI and SL

none

1.3) Reason

Within the scope of permanent quality checks we have identified a deviation in the assembly process of the oil pump fixing bolts. In some cases these bolts were not tightened according to the proper torque specification which can possibly cause oil leaks, irregular oil supply which may lead to engine stoppage.

1.4) Subject

Checking of the oil pump fixing bolts for correct torque for ROTAX engine type 912 and 914 (Series).

1.5) Compliance

- before the next flight, but at the latest by 01. August 2012 the "Checking of the oil pump fixing bolts" must be conducted according to the following instructions in section 3.

▲ **WARNING:** Non-compliance with these instructions could result in engine damages, personal injuries or death.

1.6) Approval

The technical content of this document is approved under the authority of DOA ref. EASA.21J.048.

1.7) Manpower

Estimated man-hours:
engine installed in the aircraft - - - manpower time will depend on installation and therefore no estimate is available from the engine manufacturer.

1.8) Mass data

change of weight - - - none.
moment of inertia - - - unaffected.

1.9) Electrical load data

no change

1.10) Software accomplishment summary

no change

1.11) References

In addition to this technical information refer to current issue of

- Illustrated Parts Catalog (IPC))
- Maintenance Manual (MM)

◆ NOTE: The status of Manuals can be determined by checking the table of amendments of the Manual. The 1st column of this table is the revision status. Compare this number to that listed on the ROTAX WebSite: www.rotax-aircraft-engines.com. Updates and current revisions can be downloaded for free.

1.12) Other publications affected

none

1.13) Interchangeability of parts

not affected

2) Material Information

2.1) Material - cost and availability

Price and availability will be supplied on request by ROTAX® Authorized Distributors or their Service Center.

2.2) Company support information

none

2.3) Material requirement per engine

Parts requirement in case of leaks:

- consumables e. g. O-rings, gasket rings and spare parts of the valve train in accordance with the relevant Illustrated Parts Catalog.

2.4) Material requirement per spare part

none

2.5) Rework of parts

none

2.6) Special tooling/lubricant-/adhesives-/sealing compound

Price and availability will be supplied on request by ROTAX® Authorized Distributors or their Service Center.

item no	New part no	Qty/engine	Description	Old part no.	remarks
-	-	1	valve spring loading jig assy.	877387*	valve spring
-	-	AR	slide paste MOLYKOTE G_N	297433	rocker arm bearing
-	-	1	screw nipple	276855*	spark plug tapping

* or equivalent

■ CAUTION: In using these special tools, observe the manufacturer's specifications.

3) Accomplishment / Instructions

- ◆ NOTE: Before maintenance, review the entire documentation to make sure you have a complete understanding of the procedure and requirements to prevent mistakes from an incomplete review of all of the information in this document.

Accomplishment

All the measures must be taken and confirmed by the following persons or facilities:

- ROTAX® -Airworthiness representative
- ROTAX® -Distributors or their Service Centers
- Persons approved by the respective Aviation Authority

▲ WARNING: Proceed with this work only in a non-smoking area and not close to sparks or open flames. Switch off ignition and secure engine against unintentional operation. Secure aircraft against unauthorized operation. Disconnect negative terminal of aircraft battery.

▲ WARNING: Risk of scalds and burns! Allow engine to cool sufficiently and use appropriate safety gear while performing work.

▲ WARNING: Should removal of a locking device (e.g. lock tabs, self-locking fasteners, etc.) be required when undergoing disassembly/assembly, always replace with a new one.

- ◆ NOTE: All work has to be performed in accordance with the relevant Maintenance Manual.

3.1) Inspection of the oil pump/valve train

■ CAUTION: The following steps are important, read carefully!

1. Perform inspection for oil leaks in the area of the oil pump. See fig. 1.
2. If you notice oil leaks then all following tasks have to be performed from section 3.1.1 to 3.3 inclusive.
3. If you notice no oil leaks then only the section 3.1.1 need to be performed.

- ◆ NOTE: The torque control must be performed on all affected engines, regardless of any oil leaks.

3.1.1) Inspection of the specified tightening torque for the oil pump fixing bolts

- ◆ NOTE: Tighten allen screws in a crosswise sequence!

1. Check and/or tighten the 4 oil pump (1) allen screws (2) with lock washer to 10 Nm (90 in.lb.).

3.1.2) Inspect the oil pump (required if oil leaks on oil pump discovered)

1. Remove the oil pump in accordance with the relevant Maintenance Manual (Heavy).
2. Inspect the surfaces for wear, cracks or damages.
3. Replace all O-rings (3) and gasket rings (4). Spare and replacement parts should be ordered using the current Illustrated Parts Catalog.
4. Install the oil pump in accordance with the relevant Maintenance Manual (Heavy).

3.1.3) Inspect of valve train (required if oil leaks on oil pump discovered)

See fig. 2.

The following steps are necessary to rule out a pre-damage of the valve train:

1. Remove the spark plug connector and the 4 top spark plugs (1).

■ CAUTION: Prevent entering of foreign matter through spark plug hole.

2. Remove Allen screw (2) M6x30 with washer (3) from valve cover (4).
3. Remove large and small O-ring (5) and (6).
4. Tap valve spring retainers slightly with a soft mallet to loosen valve spring retainers from the valve cotteners.
5. Turn crankshaft so that the respective piston is exactly on ignition top dead centre (compression stroke).
6. Remove the external cap nut (7) (exhaust side of cylinder).

- CAUTION: Do not remove the other cylinder head nuts. During removal of the cylinder head nut, the head stud may come loose requiring re-installation as per current Maintenance Manual. Tightening torque of the stud 3 Nm (26 in.lb.)
- 7. Attach the support plate (8) for the valve spring loading jig (9) with 2 hex. screws (10) M6x16 at the attachment points (11) on the cylinders.
- 8. Attach the valve spring loading jig on cylinder head and support plate with 2 Allen screws (12) M6x70.
- 9. Fit the screw nipple (13) into the spark plug hole.
- CAUTION: At fitting of the screw nipple take care not to damage the spark plug threads.
- 10. Securely hold crankshaft in top dead centre position for respective cylinder by utilizing a socket wrench on magneto side.
- 11. Admit approximately 2 bar (30 psi) air pressure into cylinder.
- ▲ WARNING: Risk of injury due to rotating socket wrench. Failure to adequately secure the crankshaft in a fully stable position could lead to un-intentional rotation of the crankshaft resulting in serious injury. Remove socket wrench after positioning.
- 12. Depress the 2 valve spring evenly by the valve spring loading jig (9) until the valve cotters are easily accessible. Simultaneously both hydraulic tappets will be relieved.
- 13. Remove rocker arm shaft (14).
- CAUTION: At removal take care not to damage the rocker arm shaft bearings in the cylinder head.
- 14. Remove both rocker arms (15) and (16).
- 15. Remove the valve cotters (17).
- ◆ NOTE: To facilitate the removal of valve cotters use grease or magnet.
- 16. Remove the valve spring loading jig (9).
- 17. Remove the valve spring retainers (18).
- 18. Remove the inlet- and outlet valve springs.
- 19. Remove the washers.
- 20. Check the washers for increased wear.
- 21. Assessment of washers:
- ◆ NOTE: For proper assessment of washers see Maintenance Manual Heavy chapter 72-00-00.

Less than < 0.02 mm (0.0008 in.)

Reassembly the cylinder head.
See sec. 3.1.4.

Reinstall the valve cover with new O-rings.

Purge oil system according to Maintenance Manual Line chapter 12-20-00.

Greater than > 0.02 mm (0.0008 in.)

Replace the washer, valve, valve cotter and valve spring retainer.

Reassembly the cylinder head.
See sec. 3.1.4.

Purge oil system according to Maintenance Manual Line chapter 12-20-00.

Reinstall the valve cover with new O-rings.

3.1.4) Assembly of the cylinder head

See fig. 2.

◆ NOTE: To facilitate installation apply a bit of grease so that the valve spring retainer (18) will remain on the valve spring.

1. Insert the washers.
2. Insert the inlet- and outlet valve springs.
3. Re-fit the valve spring loading jig assy (9) analogous to procedure for removal of the valve spring retainers.
4. Depress the 2 valve springs evenly by screwing in the 2 Allen screws (12) until the valve cotters can be inserted.

◆ NOTE: If the valve spring loading jig (9) does not press down the valve spring retainer correctly it could touch the valve system, possibly resulting in pressure loss in the cylinder.

5. Insert 2 new valve cotters (17) per valve.

◆ NOTE: To facilitate the fitting apply a bit of grease so that the valve cotters will remain in position.

6. Relieve pressure in the cylinder.
7. Push valve inwards so that the valve cotters will stay in position.
8. Apply MOLYKOTE G-N to the bore in the rocker arm, to the push rod tip and the valve contact surface.
9. Make sure that the piston of the respective cylinders remains in compression top dead centre.

◆ NOTE: Loss of top dead centre positioning of respective cylinder could result in difficulty of rocker arm installation. If necessary reposition to top dead centre.

10. Place inlet rocker arm (15) and outlet rocker arm (16) into position, apply MOLYKOTE G-N on both ends of rocker arm shaft (14) and insert it into its bore in cylinder head.

■ CAUTION: The rocker arm bearing is a slide fit. Do not apply force.

11. Remove the valve spring loading jig (9) and the support plate (8).
12. Re-install cylinder head nut as per current Maintenance Manual.
13. Verify proper fit of the valve cotters and secure fit in valve spring retainer by tapping with a soft mallet.
14. Lubricate all moving parts in the rocker arm space.
15. Clean the sealing surface of cylinder head and valve cover.
16. Insert new O-ring (5) 105x2,5 and O-ring (6) 6,4x1,8 into the valve cover (4).
17. Fit valve cover.

◆ NOTE: Between the 2 valve covers a gap of min. 0,2 (.008 in.) must remain. The covers must not touch each other.

18. Tighten the new Allen screw (2) M6x30 with washer (3) to 10 Nm (90 in.lb.).

■ CAUTION: Carefully inspect the length of the valve cover screw. Check whether thread is damaged. If the screw is loose or the valve cover leaking, the oil return into the oil tank by "blow-by gas" will not properly function. Improper installation of the valve cover could lead to loss of crankcase pressure.

19. Remove the screw nipple (13) from the top spark plug hole.
20. Re-fit the wiring and top spark plug (1) and tighten to 20 Nm. Fit spark plug connector according to marking.
21. Repeat the procedure on the remaining 3 cylinders.

- Restore aircraft to original operating configuration.
- Connect negative terminal of aircraft battery.

3.2) Test run

Conduct test run including ignition check and leakage test.

3.3) Summary

These instructions (section 3) have to be conducted in accordance with compliance in section 1.5.
The execution of the mandatory Alert Service Bulletin must be confirmed in the logbook.

Approval of translation to best knowledge and judgement - in any case the original text in German language and the metric units (SI-system) are authoritative.

4) Appendix

the following drawings should convey additional information:

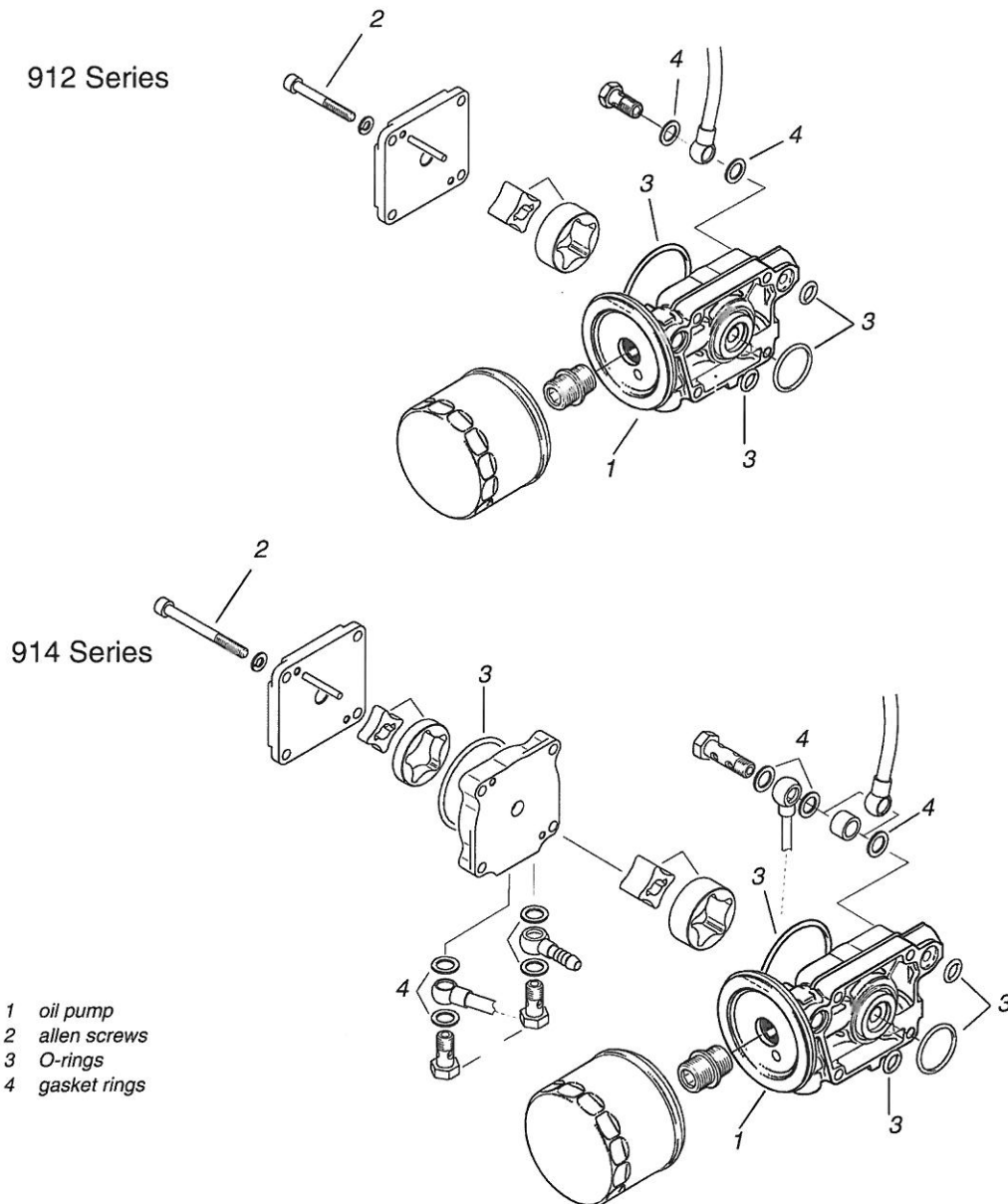

Fig. 1
Oil pump 912/914 Series

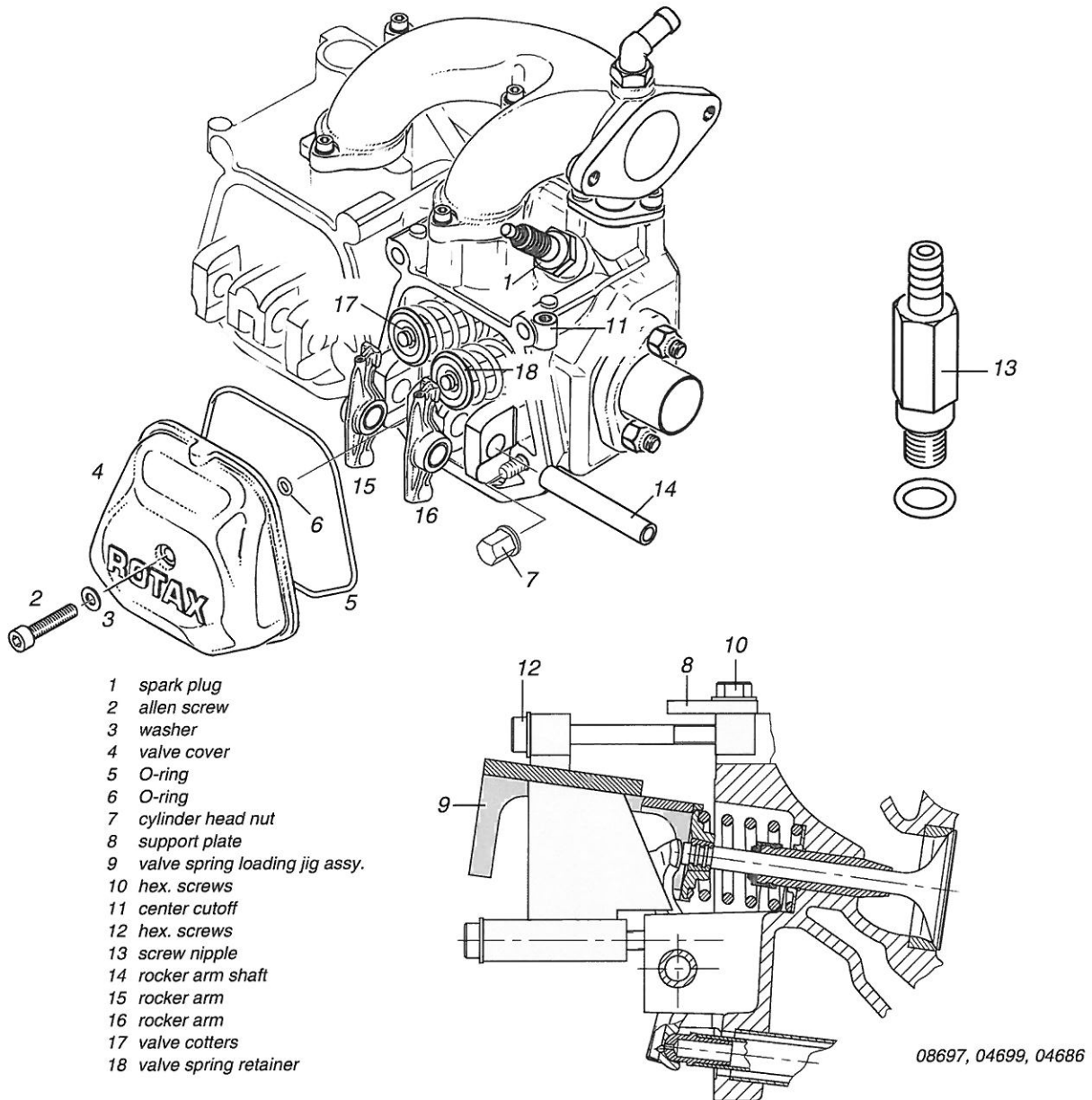

Fig. 2
valve train

◆ **NOTE:** The illustrations in this document show the typical construction. They may not represent full detail or the exact shape of the parts which have the same or similar function. Exploded views are **not technical drawings** and are for reference only. For specific detail, refer to the current documents of the respective engine type.