

SERVICE INFORMATION NO. SI 20-026

SERVICE INFORMATION NO. SI 22-014

NOTE: SI's are used **only**.
1) To distribute information from DAI to our customers.
2) To distribute applicable information / documents from our suppliers to our customers with additional information.
Typically there is no revision service for SI's. Each new information or change of that will be send along with a new SI.

I. TECHNICAL DETAILS

1.1 Airplanes affected:

DV 20 all aircraft equipped with BRP-Rotax 912A, 912F, 912S and 914F engines
DV 22 all aircraft equipped with BRP-Rotax 912A, 912F, 912S and 914F engines

1.2 Subject:

EASA AD No. 2007-0025
ATA-Code: 72-00

1.3 Reason:

EASA has issued the AD No. 2007-0025 which prescribes the inspection of the crankcase of BRP-Rotax 912A, 912F, 912S and 914F engines for cracks.

1.4 Information:

For detailed technical information see EASA AD No. 2007-0025 and the Mandatory Service Bulletin "SB-912-029 R3 and SB-914-018 R3" from BRP-Rotax which is applicable without any further additions or restrictions.

II. OTHERS

The EASA AD No. 2007-0025 and the Mandatory Service Bulletin "SB-912-029 R3 and SB-914-018 R3" from BRP-Rotax is attached to this SI.

In case of doubt contact BRP-Rotax GmbH & Co. KG or Diamond Aircraft Industries GmbH.

EASA	AIRWORTHINESS DIRECTIVE	
	<p>AD No : 2007-0025</p> <p>Date: 01 February 2007</p>	
No person may operate an aircraft to which an Airworthiness Directive applies, except in accordance with the requirements of that Airworthiness Directive unless otherwise agreed with the Authority of the State of Registry.		
<p>Type Approval Holder's Name : BRP-Rotax GmbH & Co. KG</p>	<p>Type/Model designation(s) : Rotax 912 series and Rotax 914 series</p>	
TCDS Number : Austria TW8/89, TW9-ACG, TW10-ACG		
Foreign AD : Not applicable		
Supersedure : Austro Control GmbH A-2004-01 (EASA Approval No 2004-9379)		
ATA 72	Engine – Crankcase – Inspections	
<p>Manufacturer(s):</p>	BRP-Rotax GmbH & Co. KG; Bombardier-Rotax GmbH & Co. KG; Bombardier-Rotax GmbH;	
<p>Applicability:</p>	<p>Rotax 912 A series engines up to serial number (s/n) 4,410.689 inclusive; Rotax 912 F series engines up to s/n 4,412.914 inclusive; Rotax 912 S series engines up to s/n 4,923.308 inclusive; Rotax 914 F series engines up to s/n 4,420.606 inclusive; and any other Rotax type 912 and 914 series engine whose crankcase assembly has been replaced by a crankcase having a serial number up to s/n 27811 inclusive.</p> <p>These engines are known to be installed on, but not limited to, the following aircraft types:</p> <p>3-i Sky Arrow 650 TC, 650 TCN, 650 TCNS and 710 RG; Aeromot AMT-200 Super Ximango and AMT-300 Turbo Super Ximango; Aircraft Philipp (formerly Alpa-Werke; Nitsche) AVO 68 series Samburo; Aquila AT01; Cessna 150 and A150 series; Diamond (formerly HOAC) H 36 Dimona, HK 36 series Super Dimona, DV 20 Katana and DA20-A1 Katana; Evector-Aerotechnik EV-97 VLA; Grob G 109; Issoire APM-20 Lionceau; Reims Aviation F150 and FA150 series; Scheibe SF 36R and SF 25C;</p>	

	<p>Stemme S10-VT; Tecnam P 92-J, P 92-JS and P2002-JF; W.D. Aircraft D4 Fascination.</p> <p>Note: installation of these engines may have been done either by the respective aircraft manufacturer or by an aircraft modification through a Supplemental Type Certificate.</p>
Reason:	<p>This Airworthiness Directive (AD) results from reports of cracks in the engine crankcase. Austro Control GmbH (ACG) addressed the problem by issuing AD No 107R3 which was superseded by ACG AD A-2004-01.</p> <p>The present AD supersedes the ACG AD A-2004-01. On one hand, introduction by Rotax of an optimized crankcase assembly has permitted to reduce applicability of the new AD, when based on engines' serial numbers (s/n). On the other hand, applicability is extended for some engines that may have been fitted with certain crankcase s/n, supplied as spare parts.</p> <p>In addition, accomplishment instructions given through the relevant Service Bulletins (SB) have been detailed to better locate engine's areas that are to be scrutinised.</p> <p>The aim of this AD is to ensure that the requested engine power is available at any time to prevent a sudden loss of power that could lead to a hazardous situation in a low altitude phase of flight.</p>
Effective Date:	01 October 2004 [the effective date of AD A-2004-01]
Compliance:	<p>From the last inspection date, as requested by ACG AD A-2004-01, repeat thereafter not to exceed 110 hours, Time In Service, inspection of the engine crankcase for cracks and oil leaks as detailed in the accomplishment instructions of the corresponding Service Bulletins given as Reference Publications.</p> <p>Note: In lieu of inspecting the engine crankcase assembly, a review of the engine logbook or maintenance records is acceptable if the crankcase serial number can be definitely identified from that review.</p>
Ref. Publications:	BRP-Rotax Mandatory Service Bulletins, SB-912-029 R3 and SB-914-018 R3 or later approved revisions.
Remarks :	<ol style="list-style-type: none"> 1. If requested and appropriately substantiated the responsible EASA manager for the related product has the authority to accept Alternative Method of Compliance (AMOCs) for this AD. 2. Required actions and the risk allowance have granted publication and notification of an immediate AD, ruling out the public consultation process. 3. Enquiries regarding this AD should be addressed to the AD Focal Point, Certification Directorate, EASA; E-mail: ADs@easa.europa.eu. 4. For any question concerning the technical content of the requirements in this AD, please contact BRP-Rotax GmbH & Co.KG Ph.: +43 7246 601 0; Fax: +43 7246 601 760

ROTAX.

AIRCRAFT ENGINES

SERVICE BULLETIN

CHECKING OF THE CRANKCASE ON ROTAX® ENGINE TYPE 912 AND 914 (SERIES)

SB-912-029UL R3

SB-914-018UL R3

MANDATORY

Repeating symbols:

Please, pay attention to the following symbols throughout this document emphasizing particular information.

▲ **WARNING:** Identifies an instruction, which if not followed, may cause serious injury or even death.

■ **CAUTION:** Denotes an instruction which if not followed, may severely damage the engine or could lead to suspension of warranty.

◆ **NOTE:** Information useful for better handling.

1) Planning information

1.1) Engines affected

All versions of the engine type:

- 912 UL to S/N 4,407.859
- 912 ULS to S/N 5,646.559
- 912 ULSFR to S/N 4,430.310
- 914 UL to S/N 4,419.315
- V912 pre-production
- V914 pre-production

All crankcase assy. supplied as replacement part with the following serial numbers:
up to and including S/N 27811

For complete instructions and compliance to this service bulletin refer to Service Bulletin SB-912-029 and SB-914-018, latest edition section 1.2 onward.

- ◆ **NOTE:** Section 1.6) Approval: Is not required for engines of the type UL (series).
Section 3) Accomplishment: In addition: persons with adequate type-specific training.

02392

JULY 11 2006

Current valid documentation see:
www.rotax-aircraft-engines.com

SB-912- 029UL R3
SB-914- 018UL R3
page 1 of 1

Copyright - ROTAX®

ROTAX.

AIRCRAFT ENGINES

SERVICE BULLETIN

CHECKING OF THE CRANKCASE

ON ROTAX® ENGINE TYPE 912 AND 914 (SERIES)

SB-912-029 R3

SB-914-018 R3

MANDATORY

Repeating symbols:

Please, pay attention to the following symbols throughout this document emphasizing particular information.

▲ **WARNING:** Identifies an instruction, which if not followed, may cause serious injury or even death.

■ **CAUTION:** Denotes an instruction which if not followed, may severely damage the engine or could lead to suspension of warranty.

◆ **NOTE:** Information useful for better handling.

1) Planning information

1.1) Engines affected

All versions of the engine type:

- 912 A to S/N 4,410.689
- 912 F to S/N 4,412.914
- 912 S to S/N 4,923.308
- 914 F to S/N 4,420.606

All crankcase assy. supplied as replacement part with the following serial numbers:
up to and including S/N 27811

1.2) Concurrent ASB/SB/SI and SL

none

1.3) Reason

Through the introduction of the optimized crankcase assy. the affected engine serial numbers were restricted.

One or more of the following could result in formation of cracks on the crankcase:

- Unapproved and untested modifications
- Improper carburetor synchronization
- Unsuitable idle speed (too low)
- Unsuitable engine suspension / non-neutralized vibrations
- Propeller balance out of tolerance
- Friction torque in the backlash range of gearbox not within tolerance
- Lack of maintenance
- Ground contact
- Excessive thermal strain
- Exceeding of maximum admissible engine speed
- Exceeding of maximum admissible manifold pressure

Vibrations, impacts, forces, thermal strain etc. could cause cracks on the crankcase.

▲ **WARNING:** Rectify any of the aforementioned without delay.

1.4) Subject

Checking of the crankcase on ROTAX® Engine type 912 and 914 (Series)

002391

JULY 11 2006

Current valid documentation see:

www.rotax-aircraft-engines.com

SB-912-029 R3

SB-914-018 R3

page 1 of 4

Copyright - ROTAX®

1.5) Compliance

- Every 100 hours the checking of crankcase must be conducted according to the following instructions in section 3.

1.6) Approval

The technical content is approved under the authority of DOA Nr. EASA.21J.048.

1.7) Manpower

- estimated man-hours:
engine installed in the aircraft - - - manpower time will depend on installation and therefore no estimate is available from the engine manufacturer

1.8) Mass data

- change of weight - - - none.
- moment of inertia - - - unaffected.

1.9) Electrical load data

no change

1.10) Software accomplishment summary

no change

1.11) References

In addition to this technical information refer to current issue of

- Illustrated Parts Catalog (IPC)
- Maintenance Manual (MM)

1.12) Other publications affected

none

1.13) Interchangeability of parts

not affected

2) Material Information

2.1) Material - cost and availability

Price and availability will be supplied on request by ROTAX[®] Authorized Distributors or their Service Centers.

2.2) Company support information

- In case of cracks on the crankcase the complete engine must be returned F.O.B. to a ROTAX[®] Authorized Distributor or Service Center.
- Shipping cost, down time, loss of income, telephone costs etc. or cost of conversion to other engine versions or additional work, as for instance simultaneous engine overhaul is not covered in this scope and will not be borne or reimbursed by ROTAX[®].

2.3) Material requirement per engine

none. The repair has to be performed by the engine manufacturer.

2.4) Material requirement per spare part

none

2.5) Rework of parts

none

**2.6) Special tooling/lubricant-/adhesives-/sealing compound -
Price and availability**

none

3) Accomplishment/Instructions

Accomplishment

All the measures must be taken and confirmed by the following persons or facilities:

- ROTAX[®] - Airworthiness representative
- ROTAX[®] - Distributors or their Service Centers
- Persons approved by the respective Aviation Authority

▲ **WARNING:** Proceed with this work only in a non-smoking area and not close to sparks or open flames. Switch off ignition and secure engine against unintentional operation.

- Secure aircraft against unauthorized operation.
- Disconnect negative terminal of aircraft battery (if a removal of engine is necessary).

3.1) Checking of crankcase:

see fig. 1

- Visually inspect the crankcase (1) and engine suspension for cracks in accordance with the relevant Maintenance Manual.

Visually inspect the crankcase especially:

- in the area of cylinder 1 upper side (2)
- between cylinder 1 and 3 upper side (3)
- in the area of cylinder 4 lower right side (4) and
- detailed inspect in the area (5). See view **A** fig. 2.

For those engines using the ROTAX[®] cooling air baffle. Visually inspect for oil leaks in area (2) and (3). If leaks are found, then further investigation to determine the cause of the oil leak is required. If the exact origin of the leak can not be determined i.e. governor, then removal of the cooling air baffle must be required.

Alternative methods of inspection may be used, i.e. bore scope, to inspect the areas without removal of the shroud.

◆ **NOTE:** If absolutely necessary, and if only a small amount of oil leakage is found, a ferry flight to a maintenance facility is permitted. Before the flight a measurement of the mean crankcase pressure at full load (min. 0,1bar) (min. 1.46 psi.) will be necessary, responsible for proper oil return from crankcase "blow-by gas" to oil tank. At a massive oil leakage replacement of engine without delay will be necessary.

- If cracks are detected the nearest ROTAX[®] Authorized Distributor (see also our official ROTAX-Web-Site: www.rotax-aircraft-engines.com) has to be informed and if necessary the engines has to be removed from aircraft and must be returned to a ROTAX[®] Authorized Distributor.
- Reconnect negative terminal of aircraft battery (after installation of engine).

3.2) Summary

These instructions (section 3) have to be conducted in accordance with compliance in section 1.5.

Confirm the implementation of the specified Service Bulletin in the Engine Log book.

▲ **WARNING:** Non-compliance with these instructions could result in engine damage, personal injury or death!

Approval of translation to best knowledge and judgement - in any case the original text in German language and the metric units (SI-system) are authoritative.

4) Appendix

The following drawings should convey additional information:

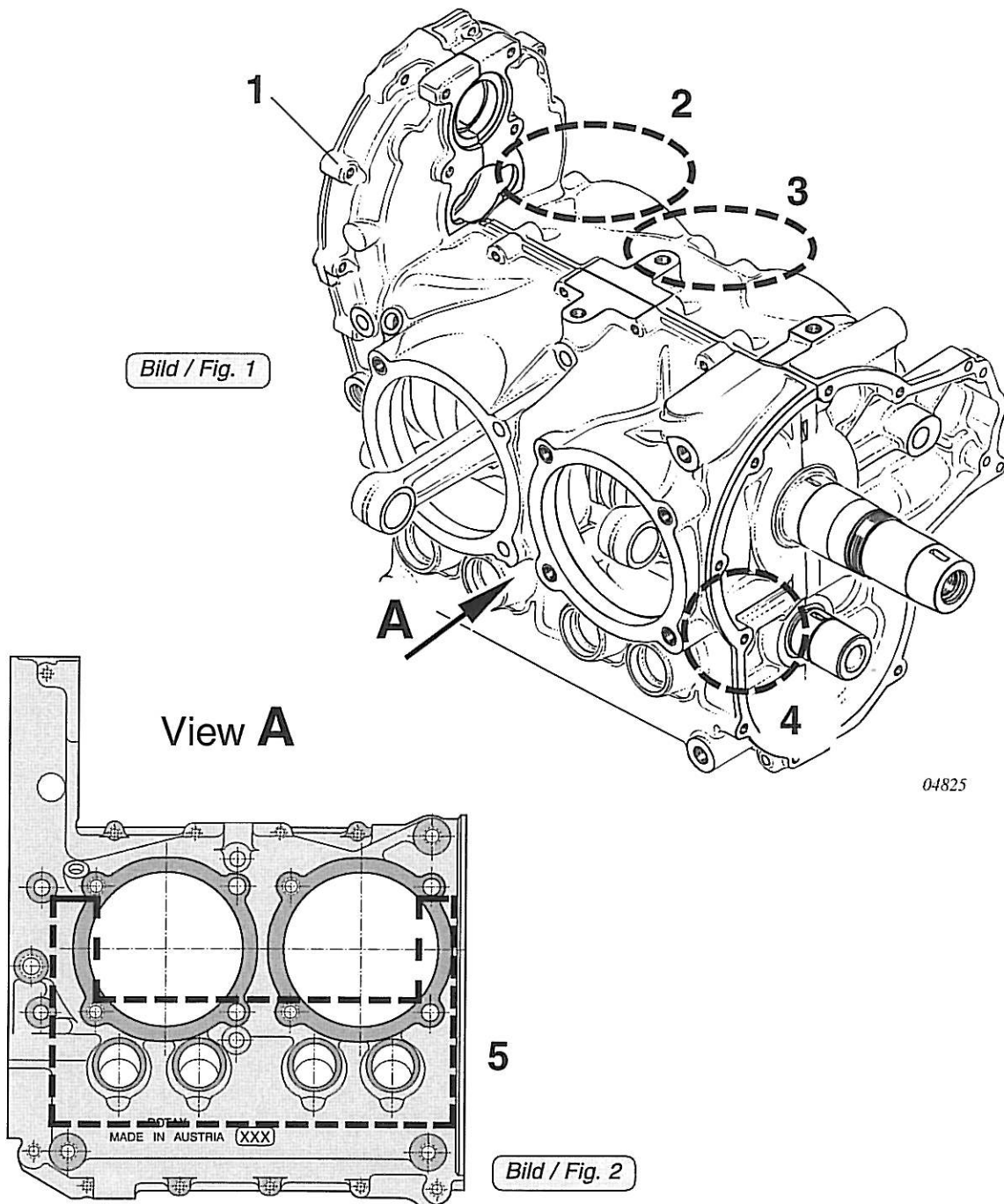

◆ **NOTE:** The illustrations in this document show the typical construction. They may not represent full detail or the exact shape of the parts which have the same or similar function. Exploded views are not technical drawings and are for reference only. For specific detail, refer to the current documents of the respective engine type.