

---

## **SERVICE INFORMATION LETTER NO. SI62-034**

NOTE: Service information letters are used only:

1. To distribute information from Diamond Aircraft Industries Inc. to our customers.
2. To distribute applicable information/documents from our suppliers to our customers with additional information.

NOTE: Typically there is no revision service for SILs. Each new information or change will be sent along with a new SIL.

### **1. TECHNICAL DETAILS**

#### **1.1 Aircraft Affected**

All DA 62 aircraft.

#### **1.2 Subject**

Inspection of ECU Backup Batteries Wiring Installation on all DA 62 aircraft.

ATA code: 24-30

#### **1.3 Reason**

It is important to observe and ensure battery connections are correct or possible electrical system failures may occur. As a result of incorrect battery connections, the engine may experience an unintended in-flight shutdown.

#### **1.4 Information**

1. Inspect the LH and RH backup batteries for correct wire connection as follows:

- A. Remove the instrument panel cover. Refer to AMM Section 25-10.
- B. Do a voltage check of pins 1 and 2 on the electrical connector J2410. See Figures 1 and 2.

NOTE: For correct wire connection of the batteries, the multimeter must read approximately 25 volts for each pin. See Figures 1 and 2.

- C. If the multimeter reads approx. 25 volts for each pin, proceed to step 10. If not, proceed to step 2.

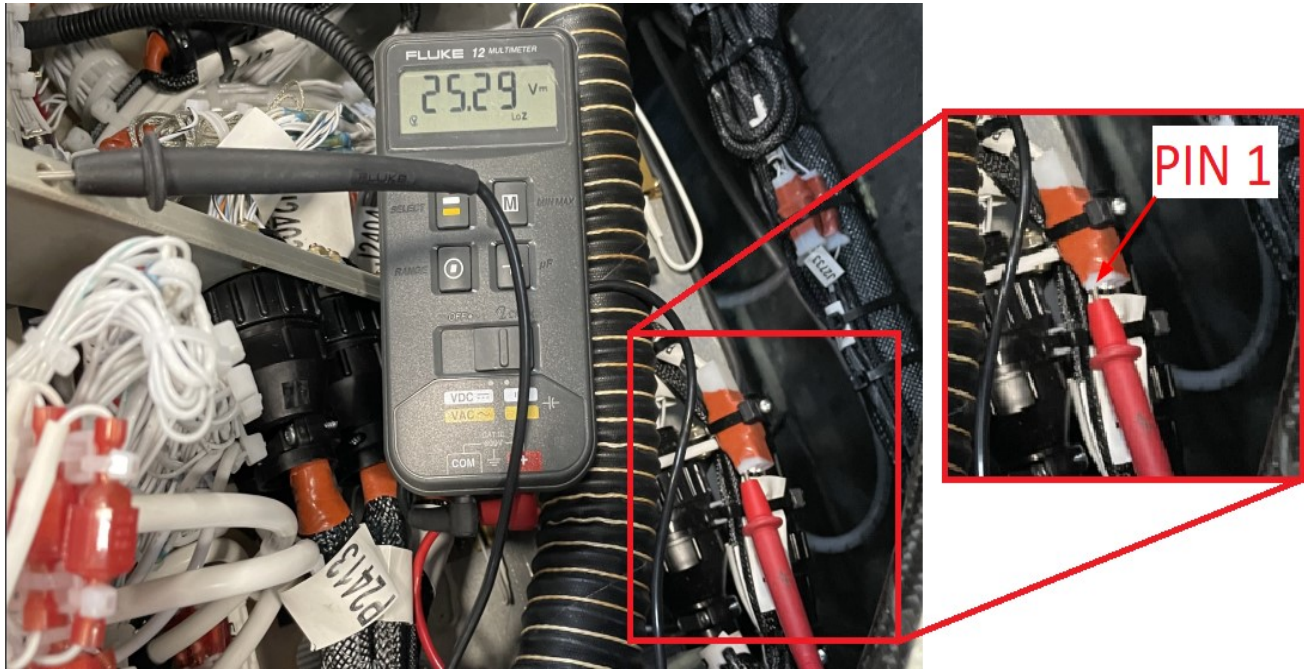

Figure 1. Voltage check of pin 1.



Figure 2. Voltage check of pin 2.

2. Remove the passenger seats. Refer to AMM Section 25-10.
3. Inspect the LH and RH ECU backup batteries connections and identify where the incorrect connections are.
4. Correct the backup batteries connections as follows:
  - A. Remove the avionic bay cover.
  - B. Disconnect the airplane main battery.
    - A. Connect the jumper cable to a positive (red) and negative (black) terminal (opposite battery of the same tray). See Figures 4, 5 and 6.
    - B. Connect the ground cable to the other negative terminal (black) of the battery. See Figures 4, 5 and 6.
    - C. Connect the fuse cable to the other positive terminal (red) of the battery. See Figures 4, 5 and 6.

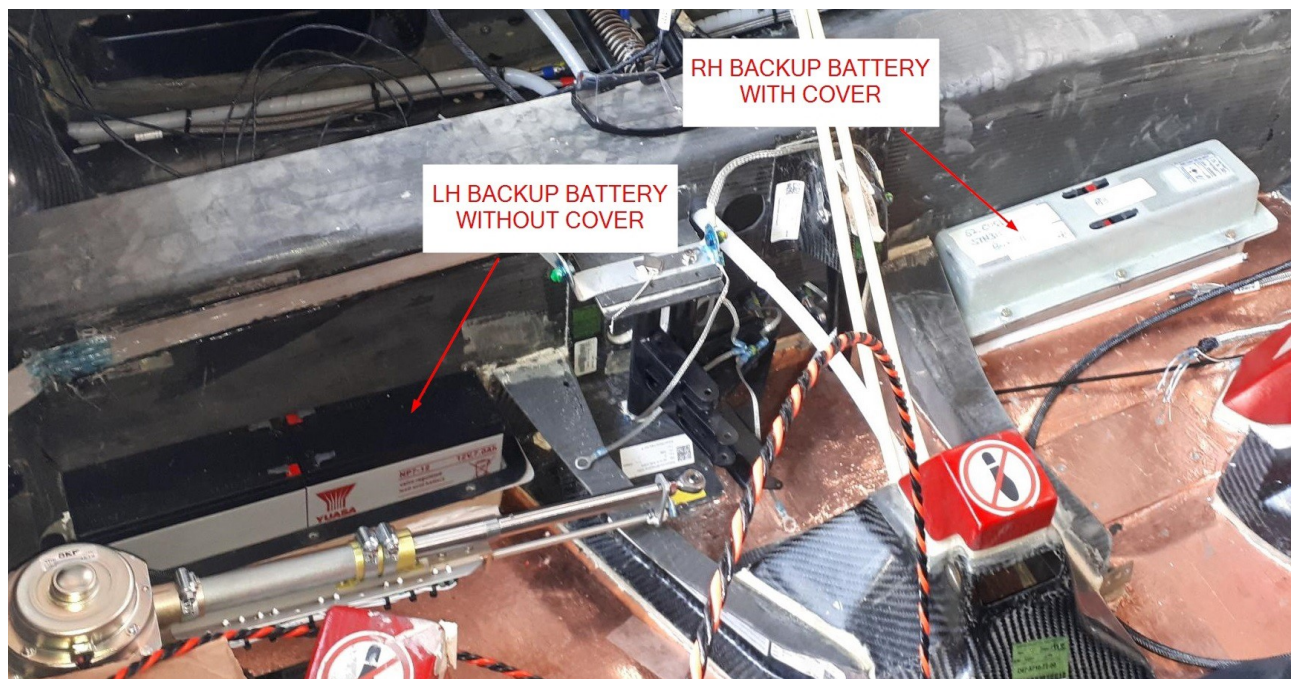

Figure 3. LH and RH battery location (cables not connected).



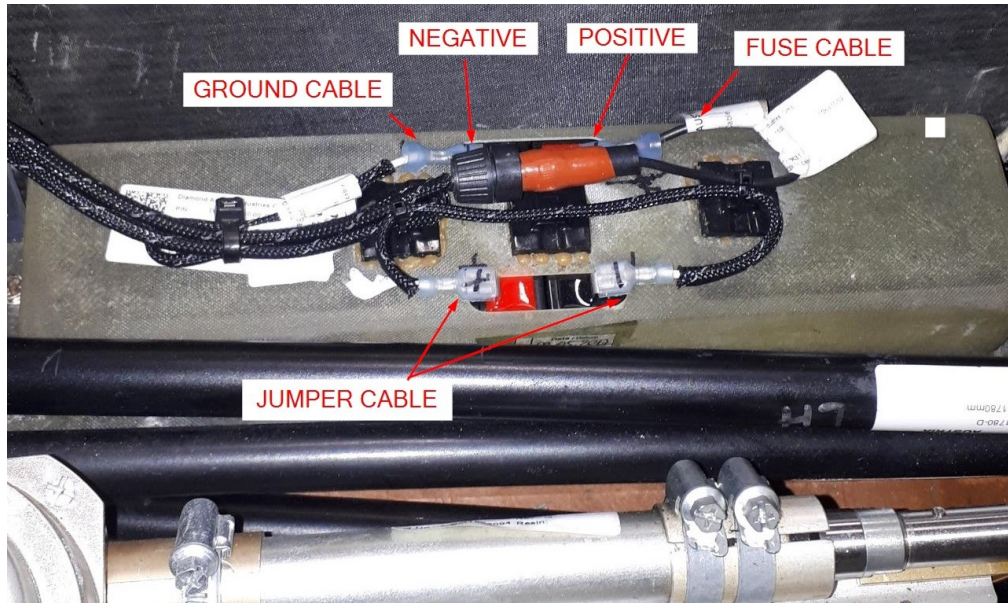

Figure 4. LH battery (cables connected).



Figure 5. RH battery (cables connected).

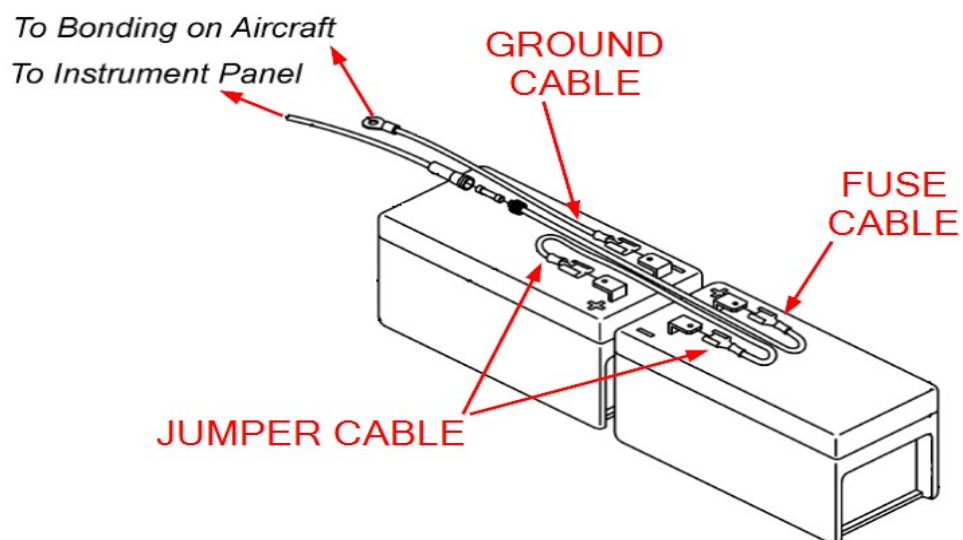

Figure 6. Battery cables.

5. Connect the airplane main battery.
6. Do a voltage check of pins 1 and 2. Refer to step 1.B.
7. Install the avionic bay cover.
8. Mark cables and battery cover with - and + for better future identification. See Figures 2 and 3.
9. Install the passenger seats. Refer to AMM Section 25-10.
10. Install the instrument panel cover. Refer to AMM Section 25-10.

---

**2. OTHER DETAILS**

To obtain satisfactory results, procedures specified in this service information letter must be accomplished in accordance with acceptable methods and current government regulations. Diamond Aircraft Industries Inc. cannot be responsible for the quality of work performed in accomplishing the requirements of this service information letter. Diamond Aircraft reserves the right to void continued warranty coverage in the area affected by this service information letter if it is not incorporated. If you no longer own the aircraft to which this service information letter applies, please forward it to the current owner and send the name of the current owner to Diamond Aircraft Industries Inc. at the address below.

Diamond Aircraft Industries Inc.  
1560 Crumlin Sideroad, London, Ontario, Canada  
N5V 1S2

Customer Support:  
Phone: (519) 457-4041, Fax: (519) 457-4045  
Email: [support-canada@diamondaircraft.com](mailto:support-canada@diamondaircraft.com)

Technical Publications:  
Email: [Techpubs@diamondaircraft.com](mailto:Techpubs@diamondaircraft.com)