

Supplement O08
TO THE AIRPLANE FLIGHT MANUAL DA 62
Pilot's Removable Stick

Doc. No. : 7.01.25-E
Date of Issue : 30-Jan-2016
Design Change Advisories : OÄM 62-025

This Supplement to the Airplane Flight Manual has been approved under the authority of DOA No. EASA.21J.052.



Intentionally left blank.

0.1 RECORD OF REVISIONS

Rev. No.	Reason	Chapter	Page(s)	Date of Revision	Approval Note	Date of Approval	Date Inserted	Signature

0.2 LIST OF EFFECTIVE PAGES

Chapter	Page	Date
0	9-O08-1	30-Jan-2016
	9-O08-2	30-Jan-2016
	9-O08-3	30-Jan-2016
	9-O08-4	30-Jan-2016
	9-O08-5	30-Jan-2016
	9-O08-6	30-Jan-2016
1	9-O08-7	30-Jan-2016
2, 3	9-O08-8	30-Jan-2016
4A	9-O08-9	30-Jan-2016
	9-O08-10	30-Jan-2016
4B, 5, 6	9-O08-11	30-Jan-2016
7	9-O08-12	30-Jan-2016
	9-O08-13	30-Jan-2016
	9-O08-14	30-Jan-2016
	9-O08-15	30-Jan-2016
8	9-O08-16	30-Jan-2016

0.3 TABLE OF CONTENTS

	Page
1. GENERAL	7
2. LIMITATIONS	8
3. EMERGENCY PROCEDURES	8
4A. NORMAL OPERATING PROCEDURES	9
4B. ABNORMAL OPERATING PROCEDURES	11
5. PERFORMANCE	11
6. MASS AND BALANCE	11
7. SYSTEM DESCRIPTION	12
8. AIRPLANE HANDLING, CARE AND MAINTENANCE	16

Intentionally left blank.

1. GENERAL

This Supplement supplies the information necessary for operation of a DA 62 with the pilot's removable stick on the RH side. It provides information for the pilot to remove and install a pilot's control stick.

The information contained in this Supplement is to be used in conjunction with the complete AFM. The limitations and information contained herein either supplement or, in the case of conflict, override those in the Airplane Flight Manual.

This Supplement is a permanent part of this AFM and must remain in this AFM at all times if OÄM 62-025 is implemented.

2. LIMITATIONS

No change.

3. EMERGENCY PROCEDURES

No change.

4A. NORMAL OPERATING PROCEDURES

4A.6 CHECKLISTS FOR NORMAL OPERATIONS

4A.6.1 PRE-FLIGHT INSPECTION

I. Cabin check

If the control stick is removed:

- h) Stick gaiter closed

NOTE

If the control stick is needed for the intended operation the control stick must be installed (refer to chapter 4A.6.22).

4A.6.22 PILOT'S REMOVABLE STICK

WARNING

Make sure that no foreign objects can fall into the control stick mechanism and the control stick gaiter does not interfere with the control stick mechanism.

Remove the Pilot's Removable Stick

- Open the leather gaiter.
- Remove the control stick gaiter and the stick assy by turning the sleeve nut counterclockwise.
- Install the dust cap to the connector thread by turning clockwise.
- Install the control stick cover.
- Make sure that the control stick cover is tightly closed in order to avoid interference of the control stick mechanism with foreign objects.
- Check the elevator and aileron controls with the remaining control stick for free and full range of movement.

Install the Pilot's Removable Stick

- Remove the control stick cover.
- Remove the dust cap from the connector thread by turning counterclockwise.
- Install the pilot's removable stick assy and tighten the sleeve nut by turning it clockwise and tighten the sleeve nut hand tight.
- Install the control stick gaiter to the control stick and secure it.
- Check the control sticks for free and full range of movement.
- Check the PTT button and the autopilot disconnection for proper function.

4B. ABNORMAL OPERATING PROCEDURES

No change.

5. PERFORMANCE

No change.

6. MASS AND BALANCE

No change.

7. SYSTEM DESCRIPTION

7.3 FLIGHT CONTROLS

Control Sticks

If OÄM 62-025 is carried out, a control stick can be removed by the pilot. The leather gaiter must be replaced by the control stick cover in order to prevent interference with the flight controls.

The installation of the control stick may also be performed by the pilot. Refer to chapter 4A.6.22 for more details about the procedures.

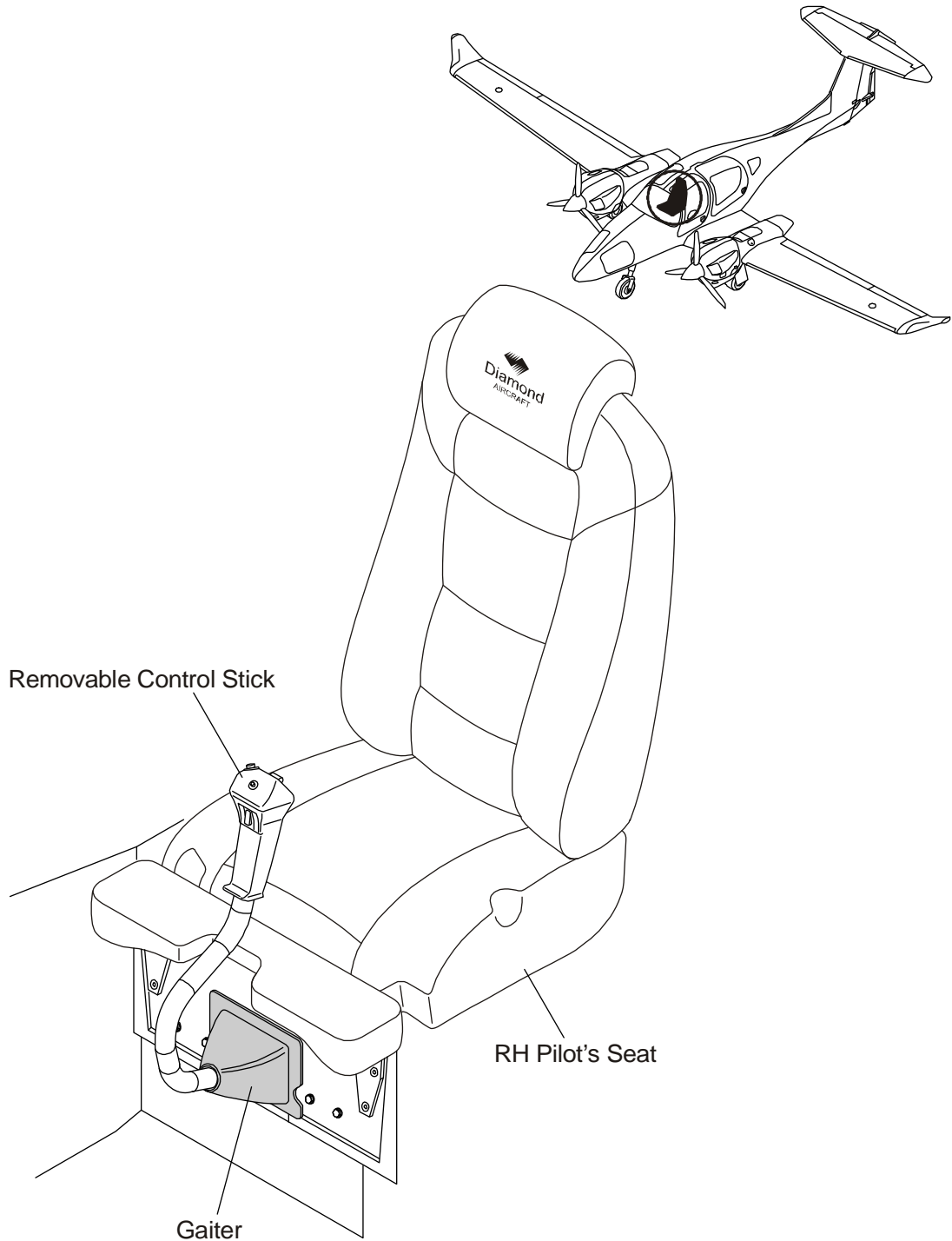

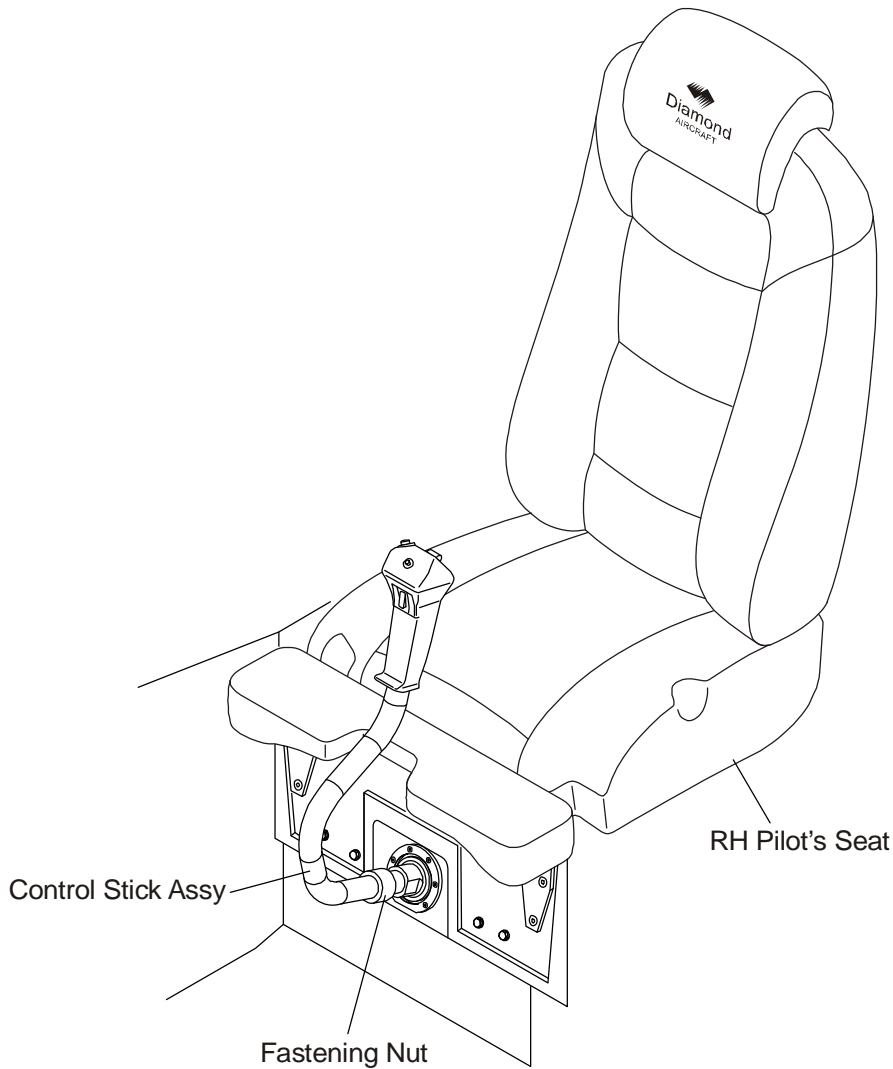
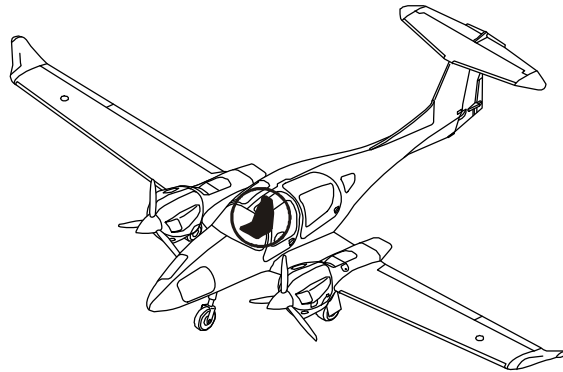

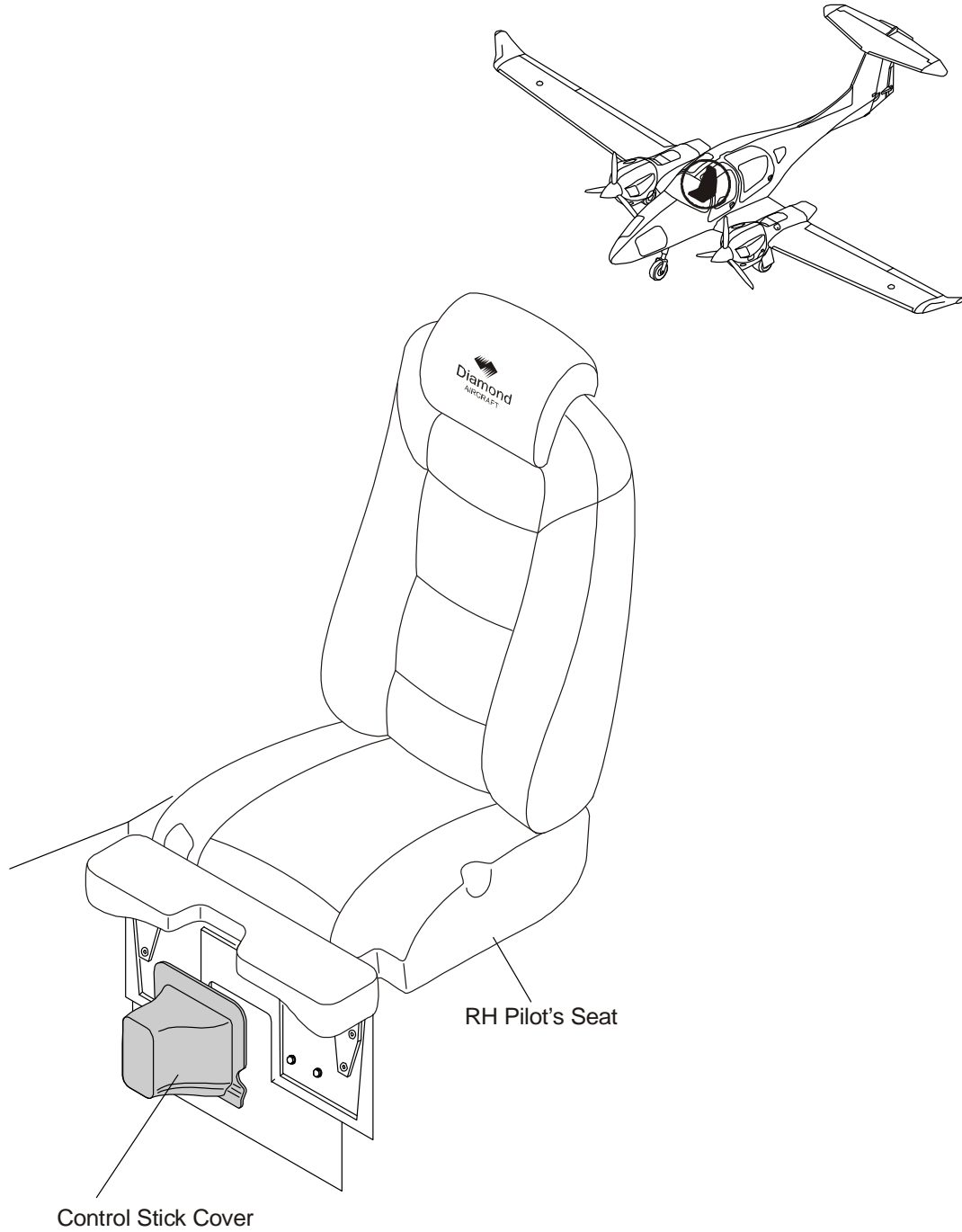

8. AIRPLANE HANDLING, CARE AND MAINTENANCE

No change.