



**SUPPLEMENT 0015 BUSINESS SEATING
CONFIGURATION PASSENGER SEAT ROW**

AFMS-0015

Doc No.: 9.01.01-0015

This Supplement to the Airplane Flight Manual has been approved by EASA under Approval No.10080955.

TABLE OF CONTENTS

Subject	Page
01 - General	01-1
01-01 -Supplement Introduction - Description	01-2
02 - Operating Limitations	02-1
02-01 -Flight Crew - Description	02-2
07 - Description of the Airplane and its Systems	07-1
07-01 -Passenger Seat - Description	07-2

LIST OF EFFECTIVE DATA MODULES

Document title	Data Module Code	Issue date
Supplement Introduction - Description	DA50O015- A-00-40-00-03A-040A-D	22-12-2022
Flight Crew - Description	DA50O015- A-15-10-00-11A-040A-D	22-12-2022
Passenger Seat - Description	DA50O015- A-25-10-00-03A-040A-D	22-12-2022

LIST OF FIGURES

Figure	Title	Page
07 - Description of the Airplane and its Systems		
1	Business Seating Configuration Passenger Seat Row	07-3

01
GENERAL

01-01 Supplement Introduction

Description

1 General

This Supplement describes an alternative Seating Configuration with OÄM 50-047 installed. The three seats of the passenger row are replaced with two single seats and a center console.

This Supplement is a permanent part of the AFM and must remain in the AFM at all times, when OÄM 50-047 is installed.

02
OPERATING LIMITATIONS

**02-01 Flight Crew
Description**

1 Flight Crew

Minimum crew	1 (one person)
Maximum passenger seating capacity	3 (three persons)

07
**DESCRIPTION OF THE AIRPLANE AND ITS
SYSTEMS**

07-01 Passenger Seat Description

1 SEATS AND SAFETY HARNESSSES

Two seats are installed in the passenger seat row.

The backrests of the passenger seat row can be laid forward after pulling upwards the release lever.

A center console is installed between the two seats. The center console has an upward foldable armrest. Under the armrest is a storage box for small items like two drinking bottles or cell phones and pens. A foam insert keeps the items in position. In front of the armrest a foam insert serves as cup holder.

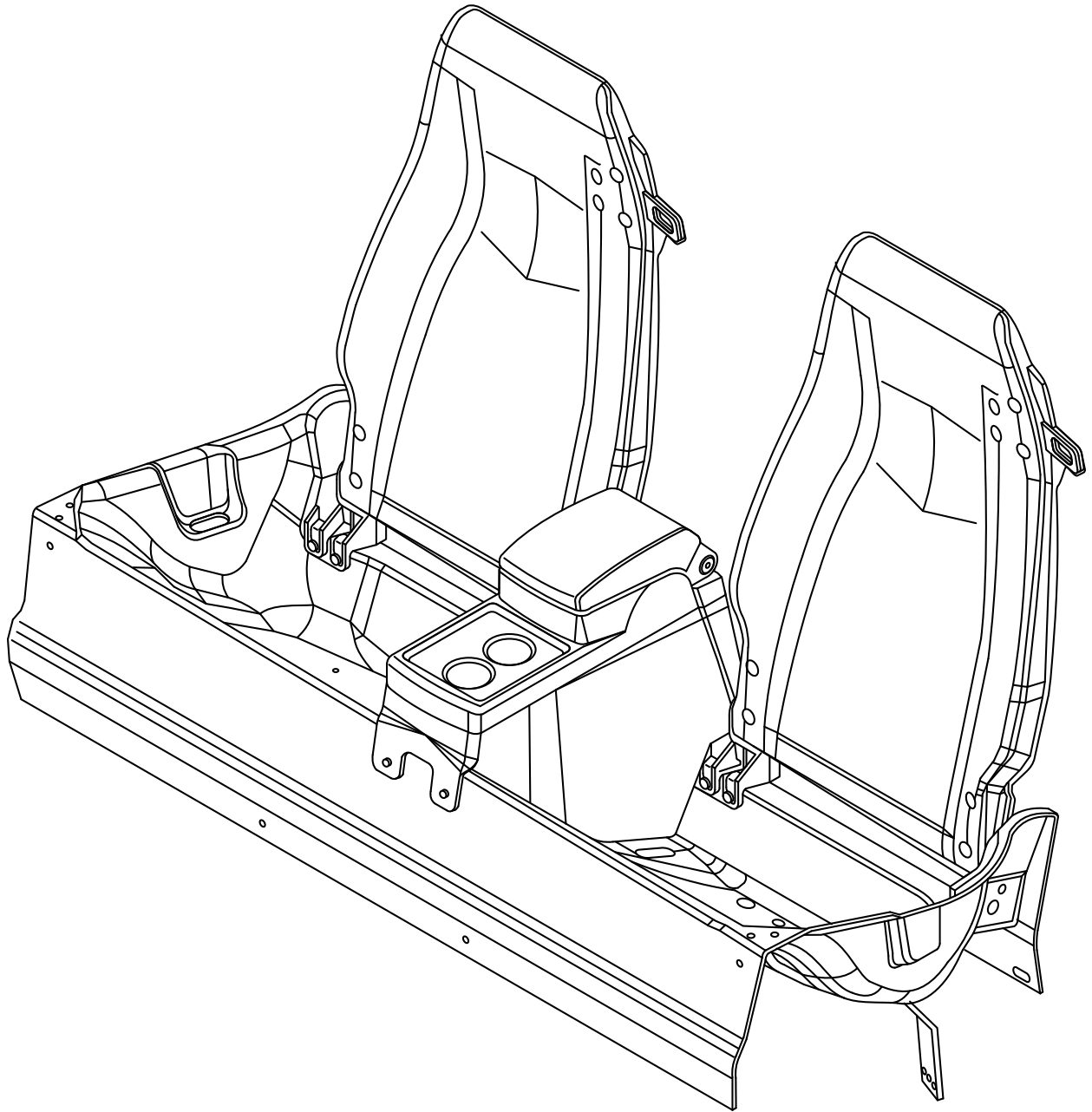

Figure 1 - Business Seating Configuration Passenger Seat Row