



---

# AIRPLANE FLIGHT MANUAL

## DA 50 C

---

**Airworthiness Category** : Normal  
**Requirement** : CS-23

**Serial Number** : \_\_\_\_\_

**Registration** : \_\_\_\_\_

**Doc. No.** : 9.01.01-E  
**Date of Issue** : 26-Aug-2020

This Airplane Flight Manual has been approved by EASA under type certificate No. EASA.A.639.

This Airplane Flight Manual is approved in accordance with 14 CFR Section 21.29 for U.S. registered aircraft, and is approved by the Federal Aviation Administration.

---

**DIAMOND AIRCRAFT INDUSTRIES GMBH**  
**N.A. OTTO-STR. 5**  
**A-2700 WIENER NEUSTADT**  
**AUSTRIA**

## TABLE OF CONTENTS

<b>Subject</b>	<b>Page</b>
<b>00 - Front Matter</b> .....	<b>00-1</b>
00-01 -Certification Basis - Description .....	00-2
00-02 -List of Incorporated AFM Changes - Change record .....	00-3
<b>01 - General</b> .....	<b>01-1</b>
01-01 -AFM Introduction - Description .....	01-2
01-02 -Warnings, Cautions and Notes - Description .....	01-3
01-03 -Dimensions and areas - Description .....	01-4
01-04 -Acronyms - Description .....	01-6
01-05 -Conversion Factors - Description .....	01-11
01-06 -Three-View Drawing - Description .....	01-13
01-07 -G1000 NXi Avionics System - Description .....	01-14
<b>02 - Operating Limitations</b> .....	<b>02-1</b>
02-01 -Aircraft release/operating limitations - Description .....	02-2
02-02 -Airspeed Limitations - Description .....	02-3
02-03 -Airspeed Indicator Markings - Description .....	02-4
02-04 -Power Plant Limitations - Description .....	02-5
02-05 -Engine Instrument Markings - Description .....	02-7
02-06 -Mass (Weight) - Description .....	02-8
02-07 -Center of Gravity - Description .....	02-9
02-08 -Approved Maneuvres, Attitudes and Flight Conditions - Description .....	02-10
02-09 -Maneuvering Load Factors - Description .....	02-11
02-10 -Operating Altitude - Description .....	02-12
02-11 -Flight Crew - Description .....	02-13
02-12 -Kinds of Operation - Description .....	02-14
02-13 -Limitation Placards - Description .....	02-16
02-14 -Fuel - Description .....	02-23
02-15 -Temperature Limitations - Description .....	02-25
02-16 -Battery Charge - Description .....	02-26
02-17 -Door Locking Device - Description .....	02-27
02-18 -Electronic Equipment - Description .....	02-28
02-19 -Smoking - Description .....	02-29
02-20 -Garmin G1000 NXi Avionics System - Description .....	02-30
02-21 -Garmin G1000 NXi GPS Navigation System Limitations - Description .....	02-33
02-22 -Autopilot Limitations - Description .....	02-36
<b>03 - Emergency Procedures</b> .....	<b>03-1</b>

<b>Subject</b>	<b>Page</b>
<b>Emergency Procedures General</b>	
03-01 -Emergency procedures - Description .....	03-3
03-02 -Certain Airspeeds in Emergencies - Description .....	03-4
03-03 -Selecting Emergency Frequency - Emergency operation procedure .....	03-5
<b>Airplane Related CAS Warnings</b>	
03-04 -Airplane related G1000 Warning Messages - Emergency operation procedure .....	03-7
03-05 -ALTN 1/2 AMPS - Emergency operation procedure .....	03-9
03-06 -ALTN 1/2 FAIL - Emergency operation procedure .....	03-10
03-07 -COOLANT TEMP - Emergency operation procedure .....	03-11
03-08 -ENG OIL TEMP - Emergency operation procedure .....	03-13
03-09 -FUEL PRESS - Emergency operation procedure .....	03-14
03-10 -GB OIL TEMP - Emergency operation procedure .....	03-15
03-11 -Unlocked Doors - Emergency operation procedure .....	03-16
03-12 -L/R FUEL TEMP - Emergency operation procedure .....	03-17
03-13 -OIL PRES - Emergency operation procedure .....	03-18
03-14 -Starter Malfunction - Emergency operation procedure .....	03-20
03-15 -ENG INTAKE - Emergency operation procedure .....	03-21
<b>Engine Failures</b>	
03-16 -Engine Failure during Take-Off - Emergency operation procedure .....	03-23
03-17 -Engine Failures on Ground - Emergency operation procedure .....	03-24
03-18 -Engine Failure in Flight - Emergency operation procedure .....	03-25
03-19 -Restart Engine in Flight - Emergency operation procedure .....	03-27
03-20 -Defective RPM Regulating System - Emergency operation procedure .....	03-28
03-21 -Defective Cowl Flap - Emergency operation procedure .....	03-30
03-22 -Inflight Engine Troubleshooting - Emergency operation procedure .....	03-31
<b>Landing Gear System Failures</b>	
03-23 -Emergency Gear Extension - Emergency operation procedure .....	03-34
03-24 -Landing with A Defective Tire on the MLG - Emergency operation procedure .....	03-35
03-25 -Landing with Defective Brakes - Emergency operation procedure .....	03-36
03-26 -Landing Gear Unsafe Warning - Emergency operation procedure .....	03-37
03-27 -Landing with Gear Up - Emergency operation procedure .....	03-38
<b>Failures in the Electrical System</b>	
03-28 -Complete Failure of the Electrical System - Emergency operation procedure .....	03-40
<b>Smoke and Fire</b>	
03-29 -Engine Fire on Ground - Emergency operation procedure .....	03-42

<b>Subject</b>	<b>Page</b>
03-30 -Electrical Fire with Smoke on Ground - Emergency operation procedure .....	03-43
03-31 -If Take-Off Can Be Aborted - Emergency operation procedure .....	03-44
03-32 -If Take-Off CANNOT Be Aborted - Emergency operation procedure .....	03-45
03-33 -Engine Fire in Flight - Emergency operation procedure .....	03-46
03-34 -Electrical Fire with Smoke in Flight - Emergency operation procedure .....	03-47
<b>Other Emergencies</b>	
03-35 -Unintentional Flight Into Icing Conditions - Emergency operation procedure .....	03-49
03-36 -Suspicion of Carbon Monoxide Contamination in the Cabin - Emergency operation procedure .....	03-50
03-37 -Recovery from Spin - Emergency operation procedure .....	03-51
03-38 -Gliding - Emergency operation procedure .....	03-52
03-39 -Emergency Descent - Emergency operation procedure .....	03-53
03-40 -Emergency Exit - Emergency operation procedure .....	03-54
03-41 -Emergency Landing with Engine Off - Emergency operation procedure .....	03-55
03-42 -Autopilot or Electric Trim Malfunction / Failure - Emergency operation procedure .....	03-56
<b>03A - Abnormal Operating Procedures .....</b>	<b>03A-1</b>
<b>Airplane Related CAS Cautions</b>	
03A-01 -Airplane related G1000 Caution Messages - Emergency operation procedure .....	03A-3
03A-02 -ALTN 1 FAIL - Special operation .....	03A-5
03A-03 -ALTN 2 FAIL - Special operation .....	03A-6
03A-04 -CHECK GEAR - Special operation .....	03A-7
03A-05 -COOLANT LVL - Special operation .....	03A-8
03A-06 -ECU A FAIL - Special operation .....	03A-9
03A-07 -ECU B FAIL - Special operation .....	03A-10
03A-08 -FUEL LOW - Special operation .....	03A-11
03A-09 -PITOT HEAT FAIL / PITOT HEAT OFF - Special operation .....	03A-12
03A-10 -STALL HT FAIL / STALL HT OFF - Special operation .....	03A-13
03A-11 -VOLTS LOW - Special operation .....	03A-14
03A-12 -STALL WARN FAIL - Special operation .....	03A-15
03A-13 -ENG INTAKE - Special operation .....	03A-16
<b>Abnormal Procedures</b>	
03A-14 -Failure in the Electrical Rudder Trim System - Special operation .....	03A-18
03A-15 -Failure in Flap Operating System - Special operation .....	03A-19
03A-16 -Before Starting Engine with External Power - Special operation .....	03A-20

<b>Subject</b>	<b>Page</b>
03A-17 -Starting Engine with External Power - Special operation .....	03A-22
03A-18 -Lightning Strike - Special operation .....	03A-24
03A-19 -Defective Fuel Transfer System - Emergency operation procedure .....	03A-25
<b>Autopilot Failures</b>	
03A-20 -Autopilot Disconnect - Emergency operation procedure .....	03A-27
03A-21 -Autopilot Overspeed Recovery - Emergency operation procedure .....	03A-28
03A-22 -Loss of Navigation Information - Emergency operation procedure .....	03A-29
03A-23 -Autopilot Out Of Trim - Emergency operation procedure .....	03A-30
03A-24 -Flashing Yellow Mode Annunciation - Emergency operation procedure .....	03A-32
03A-25 -Effects Of G1000 NXi Losses Upon Autopilot Operation - Description .....	03A-33
<b>04 - Normal Operating Procedures .....</b>	<b>04-1</b>
<b>Normal Operating Procedures General</b>	
04-01 -Normal Operating Procedures - Description .....	04-3
04-02 -Flight Characteristics - Description .....	04-4
04-03 -Airspeeds for Normal Operation - Description .....	04-5
<b>Daily Check</b>	
04-04 -Daily Checks - Pre-operation procedure .....	04-7
<b>Checklists for Normal Operating Procedures</b>	
04-05 -Pre-Flight Inspection - Cabin Check - Pre-operation procedure .....	04-9
04-06 -Pre-Flight Inspection - Walk Around Check - Pre-operation procedure .....	04-13
04-07 -Before Starting Engine - Pre-operation procedure .....	04-18
04-08 -Starting Engine - Pre-operation procedure .....	04-20
04-09 -Before Taxiing - Pre-operation procedure .....	04-22
04-10 -Taxiing - Pre-operation procedure .....	04-24
04-11 -Before Take-Off - Pre-operation procedure .....	04-25
04-12 -Take-Off - Normal operation procedure .....	04-29
04-13 -Climb - Normal operation procedure .....	04-31
04-14 -Climb Autopilot - Normal operation procedure .....	04-32
04-15 -Cruise - Normal operation procedure .....	04-35
04-16 -Cruise Autopilot - Normal operation procedure .....	04-36
04-17 -Fuel Transfer - Normal operation procedure .....	04-39
04-18 -Descent - Normal operation procedure .....	04-40
04-19 -Descent Autopilot - Normal operation procedure .....	04-41
04-20 -Approach and Landing - Normal operation procedure .....	04-44
04-21 -Approach and Landing Autopilot - Normal operation procedure .....	04-46
04-22 -Go Around - Normal operation procedure .....	04-48

<b>Subject</b>	<b>Page</b>
04-23 -Go Around Autopilot - Normal operation procedure .....	04-49
04-24 -After Landing - Post-operation procedure .....	04-50
04-25 -Engine Shut Down - Post-operation procedure .....	04-51
04-26 -Exit Airplane - Post-operation procedure .....	04-52
04-27 -Post Flight Inspection - Post-operation procedure .....	04-53
04-28 -Parking - Post-operation procedure .....	04-54
04-29 -Flight in Rain - Normal operation procedure .....	04-55
04-30 -Refueling - Description .....	04-56
04-31 -Flight at High Altitude - Description .....	04-58
<b>05 - Performance .....</b>	<b>05-1</b>
<b>Performance General</b>	
05-01 -Performance data - Description .....	05-3
05-02 -Use Of Performance Tables and Diagrams - Description .....	05-4
05-03 -Airspeed Calibration - Description .....	05-5
05-04 -International Standard Atmosphere - Description .....	05-7
05-05 -Stalling Speeds - Description .....	05-8
05-06 -Wind Components - Description .....	05-9
<b>Take Off Distance</b>	
05-07 -Take-Off Distance - Description .....	05-11
05-08 -Take-Off Distance 1999 kg - Description .....	05-13
05-09 -Take-Off Distance 1800 kg - Description .....	05-16
05-10 -Take-Off Distance 1600 kg - Description .....	05-19
<b>Climb Performance Take Off Climb</b>	
05-11 -Climb Performance - Take-Off Climb - Description .....	05-23
05-12 -Climb Performance - Take-Off Climb 1999 kg - Description .....	05-24
05-13 -Climb Performance - Take-Off Climb 1800 kg - Description .....	05-25
05-14 -Climb Performance - Take-Off Climb 1600 kg - Description .....	05-26
<b>Climb Performance Cruise Climb</b>	
05-15 -Climb Performance - Cruise Climb - Description .....	05-28
05-16 -Climb Performance - Cruise Climb 1999 kg - Description .....	05-29
05-17 -Climb Performance - Cruise Climb 1800 kg - Description .....	05-30
05-18 -Climb Performance - Cruise Climb 1600 kg - Description .....	05-31
<b>Time, Fuel Distance to Climb</b>	
05-19 -Time, Fuel and Distance to Climb 1999 kg - Description .....	05-33
05-20 -Time, Fuel and Distance to Climb 1800 kg - Description .....	05-34
05-21 -Time, Fuel and Distance to Climb 1600 kg - Description .....	05-35
<b>Cruise Performance</b>	

<b>Subject</b>	<b>Page</b>
05-22 -Cruise Performance - Description .....	05-37
05-23 -Cruise Performance 1999 kg - Description .....	05-38
<b>Landing Distances</b>	
05-24 -Landing Distances - Description .....	05-41
05-25 -Landing Distances 1999 kg - Description .....	05-43
05-26 -Landing Distances 1800 kg - Description .....	05-45
05-27 -Landing Distances 1600 kg - Description .....	05-47
<b>Landing Distance Abnormal Flap Position</b>	
05-28 -Landing Distances - Abnormal Flap Position 1999 kg - Description .....	05-50
05-29 -Landing Distances - Abnormal Flap Position 1800 kg - Description .....	05-52
05-30 -Landing Distances - Abnormal Flap Position 1600 kg - Description .....	05-54
<b>Go Around Climb Performance</b>	
05-31 -Go-Around Climb Performance - Description .....	05-57
05-32 -Go-Around Climb Performance 1999 kg - Description .....	05-58
05-33 -Go-Around Climb Performance 1800 kg - Description .....	05-59
05-34 -Go-Around Climb Performance 1600 kg - Description .....	05-60
<b>Glide</b>	
05-35 -Glide - Description .....	05-62
<b>Approved Noise Data</b>	
05-36 -Approved Noise Data - Description .....	05-64
<b>06 - Mass and Balance / Equipment .....</b>	<b>06-1</b>
<b>Mass and Balance</b>	
06-01 -General - Description .....	06-3
06-02 -Datum Plane - Description .....	06-4
06-03 -Mass and Balance Report - Description .....	06-5
06-04 -Flight Mass and Center of Gravity - Description .....	06-7
06-05 -Moment Arms - Description .....	06-8
06-06 -Loading Diagram - Description .....	06-9
06-07 -Calculation of Loading Condition - Description .....	06-10
06-08 -Permissible Center of Gravity Range - Description .....	06-14
06-09 -Permissible Moment Range - Description .....	06-15
<b>Equipment List</b>	
06-10 -Equipment - Description .....	06-17
<b>07 - Description of the Airplane and its Systems .....</b>	<b>07-1</b>
07-01 -Airframe - Description .....	07-2
<b>Flight Controls</b>	
07-02 -Flight Controls - Description .....	07-4

<b>Subject</b>	<b>Page</b>
07-03 -Ailerons - Description .....	07-5
07-04 -Flaps - Description .....	07-6
07-05 -Rudder - Description .....	07-7
07-06 -Elevator - Description .....	07-8
07-07 -Elevator Trim - Description .....	07-9
07-08 -Rudder Trim - Description .....	07-10
07-09 -Rudder Pedal - Description .....	07-11
<b>Instrument Panel</b>	
07-10 -Instrument Panel - Description .....	07-13
<b>Landing Gear</b>	
07-11 -Landing Gear - Description .....	07-16
07-12 -Hydraulic Gear Extension System Schematic - Description .....	07-18
07-13 -Brake System - Description .....	07-24
<b>Seats and Safety Harnesses</b>	
07-14 -Crew Seat - Description .....	07-27
<b>Doors and Interior</b>	
07-15 -LH/RH Pilot Door - Description .....	07-30
07-16 -Passenger Door - Description .....	07-31
07-17 -Emergency Exit Window - Description .....	07-32
07-18 -Egress Hammer - Description .....	07-35
07-19 -Heating and Ventilation - Description .....	07-36
<b>Powerplant</b>	
07-20 -Engine, General - Description .....	07-39
07-21 -Propeller - Description .....	07-40
07-22 -Propeller Control - Description .....	07-41
07-23 -Engine Operating Controls - Description .....	07-42
07-24 -Engine Instruments - Description .....	07-44
07-25 -Cooling System - Description .....	07-47
07-26 -Turbo-Charger System - Description .....	07-49
07-27 -FADEC - Description .....	07-51
<b>Fuel System</b>	
07-28 -Fuel System - Description .....	07-53
07-29 -Fuel Pumps - Description .....	07-55
07-30 -Fuel Valve - Description .....	07-56
07-31 -Fuel Tanks - Description .....	07-59
07-32 -Fuel Level Check Tool - Description .....	07-60
<b>Electrical Systems</b>	



<b>Subject</b>	<b>Page</b>
07-33 -Electrical System - Description .....	07-66
07-34 -Standby Attitude Module - Description .....	07-69
07-35 -Crew Alerting System (CAS) - Description .....	07-70
<b>Garmin G1000 NXI</b>	
07-36 -Garmin G1000 NXi Integrated Avionics System - Description .....	07-73
07-37 -Primary Flight Display (PFD) - Description .....	07-74
07-38 -Multi-Function Display (MFD) - Description .....	07-76
07-39 -Audio Panel - Description .....	07-77
07-40 -Attitude and Heading Reference System (AHRS) - Description .....	07-78
07-41 -Air Data Computer (ADC) - Description .....	07-79
07-42 -PFD / MFD Control Unit (KEYPAD) - Description .....	07-80
<b>Autopilot</b>	
07-43 -Autopilot GFC700 - Description .....	07-82
<b>Pitot Static System</b>	
07-44 -Pitot-Static System - Description .....	07-88
<b>Stall Warning System</b>	
07-45 -Stall Warning System - Description .....	07-90
<b>Baggage Compartment</b>	
07-46 -Baggage Compartment - Description .....	07-92
07-47 -Trim Weight - Description .....	07-97
<b>08 - Airplane Handling, Care and Maintenance .....</b>	<b>08-1</b>
<b>General</b>	
08-01 -General - Description .....	08-3
08-02 -Airplane Inspection Intervals - Description .....	08-4
08-03 -Airplane Alterations or Repairs - Description .....	08-5
<b>Servicing</b>	
08-04 -Refueling - Handling .....	08-7
08-05 -Engine Oil Level Check - Handling .....	08-9
08-06 -Gearbox Oil Level Check - Handling .....	08-10
08-07 -Tire Inflation Pressure Check - Handling .....	08-11
<b>Ground Handling</b>	
08-08 -Ground Handling - Description .....	08-13
08-09 -Parking - Description .....	08-15
08-10 -Mooring - Description .....	08-17
08-11 -Jacking - Description .....	08-18
08-12 -Cleaning and Care - Description .....	08-19
08-13 -Cleaning the Aircraft from Ice and Snow - Description .....	08-20

---

<b>Subject</b>	<b>Page</b>
<b>09 - Supplements</b> .....	<b>09-1</b>
09-01 -Supplements - Description .....	09-2

## LIST OF EFFECTIVE DATA MODULES

<b>Document title</b>	<b>Data Module Code</b>	<b>Issue date</b>
Certification Basis - Description	DA50-A-00-00-00-01A-040A-D	16-05-2022
List of Incorporated AFM Changes - Change record	DA50-A-00-40-01-00A-00TA-D	06-12-2023
AFM Introduction - Description	DA50-A-00-40-00-01A-040A-D	06-12-2023
Warnings, Cautions and Notes - Description	DA50-A-00-40-00-05A-040A-D	26-08-2020
Dimensions and areas - Description	DA50-A-06-00-00-00A-040A-D	18-02-2022
Acronyms - Description	DA50-A-00-40-00-06A-040A-D	17-01-2022
Conversion Factors - Description	DA50-A-06-00-01-00A-040A-D	26-08-2020
Three-View Drawing - Description	DA50-A-06-00-00-01A-040A-D	18-02-2022
G1000 NXi Avionics System - Description	DA50-A-34-00-00-99A-040A-D	17-01-2022
Aircraft release/operating limitations - Description	DA50-A-15-10-00-00A-040A-D	26-08-2020
Airspeed Limitations - Description	DA50-A-15-10-00-01A-040A-D	28-05-2021
Airspeed Indicator Markings - Description	DA50-A-15-10-00-02A-040A-D	26-08-2020
Power Plant Limitations - Description	DA50-A-15-10-00-04A-040A-D	28-05-2021
Engine Instrument Markings - Description	DA50-A-15-10-00-05A-040A-D	27-10-2021
Mass (Weight) - Description	DA50-A-15-10-00-06A-040A-D	25-05-2021
Center of Gravity - Description	DA50-A-15-10-00-07A-040A-D	13-12-2022
Approved Maneuvres, Attitudes and Flight Conditions - Description	DA50-A-15-10-00-08A-040A-D	28-05-2021
Maneuvering Load Factors - Description	DA50-A-15-10-00-09A-040A-D	28-05-2021
Operating Altitude - Description	DA50-A-15-10-00-10A-040A-D	26-08-2020
Flight Crew - Description	DA50-A-15-10-00-11A-040A-D	26-08-2020
Kinds of Operation - Description	DA50-A-15-10-00-12A-040A-D	26-06-2023
Limitation Placards - Description	DA50-A-11-30-00-99A-040A-D	13-12-2022
Fuel - Description	DA50-A-15-10-00-13A-040A-D	30-11-2022
Temperature Limitations - Description	DA50-A-15-10-00-15A-040A-D	25-05-2021
Battery Charge - Description	DA50-A-15-10-00-16A-040A-D	26-08-2020
Door Locking Device - Description	DA50-A-15-10-00-17A-040A-D	26-08-2020
Electronic Equipment - Description	DA50-A-15-10-00-18A-040A-D	17-01-2022
Smoking - Description	DA50-A-15-10-00-19A-040A-D	26-08-2020
Garmin G1000 NXi Avionics System - Description	DA50-A-15-10-00-24A-040A-D	18-05-2022
Garmin G1000 NXi GPS Navigation System Limitations - Description	DA50-A-15-10-00-25A-040A-D	28-05-2021
Autopilot Limitations - Description	DA50-A-15-10-00-21A-040A-D	15-07-2021
Emergency procedures - Description	DA50-A-15-40-00-00A-040A-D	26-08-2020
Certain Airspeeds in Emergencies - Description	DA50-A-15-41-01-00A-040A-D	28-05-2021

Document title	Data Module Code	Issue date
Selecting Emergency Frequency - Emergency operation procedure	<a href="#">DA50-A-15-41-02-00A-141A-D</a>	26-08-2020
Airplane related G1000 Warning Messages - Emergency operation procedure	<a href="#">DA50-A-15-49-00-00A-141A-D</a>	18-05-2022
ALTN 1/2 AMPS - Emergency operation procedure	<a href="#">DA50-A-15-42-00-03A-141A-D</a>	26-08-2020
ALTN 1/2 FAIL - Emergency operation procedure	<a href="#">DA50-A-15-42-00-04A-141A-D</a>	16-08-2022
COOLANT TEMP - Emergency operation procedure	<a href="#">DA50-A-15-45-00-01A-141A-D</a>	28-05-2021
ENG OIL TEMP - Emergency operation procedure	<a href="#">DA50-A-15-45-00-03A-141A-D</a>	28-05-2021
FUEL PRESS - Emergency operation procedure	<a href="#">DA50-A-15-44-02-02A-141A-D</a>	28-05-2021
GB OIL TEMP - Emergency operation procedure	<a href="#">DA50-A-15-45-00-04A-141A-D</a>	28-05-2021
Unlocked Doors - Emergency operation procedure	<a href="#">DA50-A-15-41-00-03A-141A-D</a>	26-08-2020
L/R FUEL TEMP - Emergency operation procedure	<a href="#">DA50-A-15-44-02-04A-141A-D</a>	28-05-2021
OIL PRES - Emergency operation procedure	<a href="#">DA50-A-15-45-00-02A-141A-D</a>	28-05-2021
Starter Malfunction - Emergency operation procedure	<a href="#">DA50-A-15-42-00-02A-141A-D</a>	26-05-2021
ENG INTAKE - Emergency operation procedure	<a href="#">DA50-A-15-45-00-06A-141A-D</a>	18-05-2022
Engine Failure during Take-Off - Emergency operation procedure	<a href="#">DA50-A-15-45-01-01A-141A-D</a>	09-09-2021
Engine Failures on Ground - Emergency operation procedure	<a href="#">DA50-A-15-45-00-00A-141A-D</a>	28-05-2021
Engine Failure in Flight - Emergency operation procedure	<a href="#">DA50-A-15-45-01-02A-141A-D</a>	28-05-2021
Restart Engine in Flight - Emergency operation procedure	<a href="#">DA50-A-15-45-01-03A-141A-D</a>	28-05-2021
Defective RPM Regulating System - Emergency operation procedure	<a href="#">DA50-A-15-45-01-05A-141A-D</a>	28-05-2021
Defective Cowl Flap - Emergency operation procedure	<a href="#">DA50-A-15-45-00-05A-141A-D</a>	28-05-2021
Inflight Engine Troubleshooting - Emergency operation procedure	<a href="#">DA50-A-15-45-01-00A-141A-D</a>	09-09-2021
Emergency Gear Extension - Emergency operation procedure	<a href="#">DA50-A-15-44-01-01A-141A-D</a>	28-05-2021
Landing with A Defective Tire on the MLG - Emergency operation procedure	<a href="#">DA50-A-15-44-01-03A-141A-D</a>	28-05-2021
Landing with Defective Brakes - Emergency operation procedure	<a href="#">DA50-A-15-44-01-04A-141A-D</a>	28-05-2021
Landing Gear Unsafe Warning - Emergency operation procedure	<a href="#">DA50-A-15-44-01-00A-141A-D</a>	09-09-2021
Landing with Gear Up - Emergency operation procedure	<a href="#">DA50-A-15-44-01-02A-141A-D</a>	09-09-2021
Complete Failure of the Electrical System - Emergency operation procedure	<a href="#">DA50-A-15-42-00-00A-141A-D</a>	28-05-2021
Engine Fire on Ground - Emergency operation procedure	<a href="#">DA50-A-15-43-00-00A-141A-D</a>	28-05-2021
Electrical Fire with Smoke on Ground - Emergency operation procedure	<a href="#">DA50-A-15-43-00-01A-141A-D</a>	28-05-2021

Document title	Data Module Code	Issue date
If Take-Off Can Be Aborted - Emergency operation procedure	DA50-A-15-43-01-00A-141A-D	28-05-2021
If Take-Off CANNOT Be Aborted - Emergency operation procedure	DA50-A-15-43-01-01A-141A-D	28-05-2021
Engine Fire in Flight - Emergency operation procedure	DA50-A-15-43-02-00A-141A-D	28-05-2021
Electrical Fire with Smoke in Flight - Emergency operation procedure	DA50-A-15-43-02-01A-141A-D	28-05-2021
Unintentional Flight Into Icing Conditions - Emergency operation procedure	DA50-A-15-41-00-01A-141A-D	09-09-2021
Suspicion of Carbon Monoxide Contamination in the Cabin - Emergency operation procedure	DA50-A-15-41-00-02A-141A-D	28-05-2021
Recovery from Spin - Emergency operation procedure	DA50-A-15-41-00-06A-141A-D	28-05-2021
Gliding - Emergency operation procedure	DA50-A-15-41-00-07A-141A-D	28-05-2021
Emergency Descent - Emergency operation procedure	DA50-A-15-41-00-08A-141A-D	28-05-2021
Emergency Exit - Emergency operation procedure	DA50-A-15-46-00-01A-141A-D	25-05-2021
Emergency Landing with Engine Off - Emergency operation procedure	DA50-A-15-45-01-04A-141A-D	28-05-2021
Autopilot or Electric Trim Malfunction / Failure - Emergency operation procedure	DA50-A-15-47-10-00A-141A-D	15-07-2021
Airplane related G1000 Caution Messages - Emergency operation procedure	DA50-A-15-49-01-00A-141A-D	18-05-2022
ALTN 1 FAIL - Special operation	DA50-A-15-52-04-01A-161A-D	26-08-2020
ALTN 2 FAIL - Special operation	DA50-A-15-52-04-02A-161A-D	26-08-2020
CHECK GEAR - Special operation	DA50-A-15-52-01-01A-161A-D	28-05-2021
COOLANT LVL - Special operation	DA50-A-15-52-03-16A-161A-D	26-08-2020
ECU A FAIL - Special operation	DA50-A-15-52-03-10A-161A-D	28-05-2021
ECU B FAIL - Special operation	DA50-A-15-52-03-09A-161A-D	09-09-2021
FUEL LOW - Special operation	DA50-A-15-52-02-06A-161A-D	28-05-2021
PITOT HEAT FAIL / PITOT HEAT OFF - Special operation	DA50-A-15-52-04-05A-161A-D	28-05-2021
STALL HT FAIL / STALL HT OFF - Special operation	DA50-A-15-52-04-09A-161A-D	09-09-2021
VOLTS LOW - Special operation	DA50-A-15-52-04-12A-161A-D	26-08-2020
STALL WARN FAIL - Special operation	DA50-A-15-52-04-13A-161A-D	28-05-2021
ENG INTAKE - Special operation	DA50-A-15-52-03-19A-161A-D	18-05-2022
Failure in the Electrical Rudder Trim System - Special operation	DA50-A-15-54-00-02A-161A-D	16-05-2022
Failure in Flap Operating System - Special operation	DA50-A-15-54-00-01A-161A-D	28-05-2021
Before Starting Engine with External Power - Special operation	DA50-A-15-50-01-01A-161A-D	28-05-2021
Starting Engine with External Power - Special operation	DA50-A-15-50-01-02A-161A-D	28-05-2021
Lightning Strike - Special operation	DA50-A-15-50-02-00A-161A-D	26-08-2020

Document title	Data Module Code	Issue date
Defective Fuel Transfer System - Emergency operation procedure	DA50-A-15-44-02-01A-141A-D	28-05-2021
Autopilot Disconnect - Emergency operation procedure	DA50-A-15-47-10-01A-141A-D	15-07-2021
Autopilot Overspeed Recovery - Emergency operation procedure	DA50-A-15-47-10-02A-141A-D	15-07-2021
Loss of Navigation Information - Emergency operation procedure	DA50-A-15-47-10-03A-141A-D	15-07-2021
Autopilot Out Of Trim - Emergency operation procedure	DA50-A-15-47-10-04A-141A-D	15-07-2021
Flashing Yellow Mode Annunciation - Emergency operation procedure	DA50-A-15-47-10-05A-141A-D	15-07-2021
Effects Of G1000 NXi Losses Upon Autopilot Operation - Description	DA50-A-15-47-10-06A-040A-D	15-07-2021
Normal Operating Procedures - Description	DA50-A-15-30-00-00A-040A-D	15-07-2021
Flight Characteristics - Description	DA50-A-15-30-00-04A-040A-D	26-08-2020
Airspeeds for Normal Operation - Description	DA50-A-15-30-00-01A-040A-D	28-05-2021
Daily Checks - Pre-operation procedure	DA50-A-15-32-00-00A-121A-D	09-09-2021
Pre-Flight Inspection - Cabin Check - Pre-operation procedure	DA50-A-15-33-00-01A-121A-D	26-06-2023
Pre-Flight Inspection - Walk Around Check - Pre-operation procedure	DA50-A-15-33-00-02A-121A-D	04-07-2022
Before Starting Engine - Pre-operation procedure	DA50-A-15-33-00-03A-121A-D	09-09-2021
Starting Engine - Pre-operation procedure	DA50-A-15-33-00-04A-121A-D	28-05-2021
Before Taxiing - Pre-operation procedure	DA50-A-15-33-00-06A-121A-D	06-12-2023
Taxiing - Pre-operation procedure	DA50-A-15-33-00-07A-121A-D	28-05-2021
Before Take-Off - Pre-operation procedure	DA50-A-15-33-00-08A-121A-D	16-08-2022
Take-Off - Normal operation procedure	DA50-A-15-34-00-01A-131A-D	09-09-2021
Climb - Normal operation procedure	DA50-A-15-34-00-03A-131A-D	09-09-2021
Climb Autopilot - Normal operation procedure	DA50-A-15-34-01-03A-131A-D	15-07-2021
Cruise - Normal operation procedure	DA50-A-15-34-00-04A-131A-D	09-09-2021
Cruise Autopilot - Normal operation procedure	DA50-A-15-34-01-04A-131A-D	15-07-2021
Fuel Transfer - Normal operation procedure	DA50-A-15-34-00-05A-131A-D	28-05-2021
Descent - Normal operation procedure	DA50-A-15-34-00-06A-131A-D	17-01-2022
Descent Autopilot - Normal operation procedure	DA50-A-15-34-01-06A-131A-D	15-07-2021
Approach and Landing - Normal operation procedure	DA50-A-15-34-00-07A-131A-D	28-05-2021
Approach and Landing Autopilot - Normal operation procedure	DA50-A-15-34-01-07A-131A-D	15-07-2021
Go Around - Normal operation procedure	DA50-A-15-34-00-08A-131A-D	28-05-2021
Go Around Autopilot - Normal operation procedure	DA50-A-15-34-01-08A-131A-D	15-07-2021
After Landing - Post-operation procedure	DA50-A-15-35-00-01A-151A-D	28-05-2021
Engine Shut Down - Post-operation procedure	DA50-A-15-35-00-02A-151A-D	28-05-2021

Document title	Data Module Code	Issue date
Exit Airplane - Post-operation procedure	<a href="#">DA50-A-15-35-00-03A-151A-D</a>	26-08-2020
Post Flight Inspection - Post-operation procedure	<a href="#">DA50-A-15-35-00-04A-151A-D</a>	26-08-2020
Parking - Post-operation procedure	<a href="#">DA50-A-15-35-00-05A-151A-D</a>	16-08-2022
Flight in Rain - Normal operation procedure	<a href="#">DA50-A-15-36-00-03A-131A-D</a>	28-05-2021
Refueling - Description	<a href="#">DA50-A-15-36-00-04A-040A-D</a>	28-05-2021
Flight at High Altitude - Description	<a href="#">DA50-A-15-36-00-05A-040A-D</a>	26-08-2020
Performance data - Description	<a href="#">DA50-A-15-60-00-00A-040A-D</a>	28-05-2021
Use Of Performance Tables and Diagrams - Description	<a href="#">DA50-A-15-60-01-00A-040A-D</a>	26-08-2020
Airspeed Calibration - Description	<a href="#">DA50-A-15-61-00-00A-040A-D</a>	26-08-2020
International Standard Atmosphere - Description	<a href="#">DA50-A-15-61-02-00A-040A-D</a>	26-08-2020
Stalling Speeds - Description	<a href="#">DA50-A-15-62-08-00A-040A-D</a>	28-05-2021
Wind Components - Description	<a href="#">DA50-A-15-61-03-00A-040A-D</a>	26-06-2023
Take-Off Distance - Description	<a href="#">DA50-A-15-62-00-00A-040A-D</a>	28-05-2021
Take-Off Distance 1999 kg - Description	<a href="#">DA50-A-15-62-00-01A-040A-D</a>	09-09-2021
Take-Off Distance 1800 kg - Description	<a href="#">DA50-A-15-62-00-02A-040A-D</a>	09-09-2021
Take-Off Distance 1600 kg - Description	<a href="#">DA50-A-15-62-00-03A-040A-D</a>	09-09-2021
Climb Performance - Take-Off Climb - Description	<a href="#">DA50-A-15-62-02-00A-040A-D</a>	26-08-2020
Climb Performance - Take-Off Climb 1999 kg - Description	<a href="#">DA50-A-15-62-02-01A-040A-D</a>	06-05-2022
Climb Performance - Take-Off Climb 1800 kg - Description	<a href="#">DA50-A-15-62-02-02A-040A-D</a>	06-05-2022
Climb Performance - Take-Off Climb 1600 kg - Description	<a href="#">DA50-A-15-62-02-03A-040A-D</a>	06-05-2022
Climb Performance - Cruise Climb - Description	<a href="#">DA50-A-15-62-03-00A-040A-D</a>	26-08-2020
Climb Performance - Cruise Climb 1999 kg - Description	<a href="#">DA50-A-15-62-03-01A-040A-D</a>	06-05-2022
Climb Performance - Cruise Climb 1800 kg - Description	<a href="#">DA50-A-15-62-03-02A-040A-D</a>	06-05-2022
Climb Performance - Cruise Climb 1600 kg - Description	<a href="#">DA50-A-15-62-03-03A-040A-D</a>	06-05-2022
Time, Fuel and Distance to Climb 1999 kg - Description	<a href="#">DA50-A-15-62-01-02A-040A-D</a>	06-05-2022
Time, Fuel and Distance to Climb 1800 kg - Description	<a href="#">DA50-A-15-62-01-01A-040A-D</a>	06-05-2022
Time, Fuel and Distance to Climb 1600 kg - Description	<a href="#">DA50-A-15-62-01-00A-040A-D</a>	06-05-2022
Cruise Performance - Description	<a href="#">DA50-A-15-62-05-00A-040A-D</a>	16-05-2022
Cruise Performance 1999 kg - Description	<a href="#">DA50-A-15-62-05-01A-040A-D</a>	27-10-2021
Landing Distances - Description	<a href="#">DA50-A-15-62-06-00A-040A-D</a>	26-05-2021
Landing Distances 1999 kg - Description	<a href="#">DA50-A-15-62-06-01A-040A-D</a>	09-09-2021
Landing Distances 1800 kg - Description	<a href="#">DA50-A-15-62-06-02A-040A-D</a>	09-09-2021
Landing Distances 1600 kg - Description	<a href="#">DA50-A-15-62-06-03A-040A-D</a>	09-09-2021
Landing Distances - Abnormal Flap Position 1999 kg - Description	<a href="#">DA50-A-15-62-09-01A-040A-D</a>	09-09-2021
Landing Distances - Abnormal Flap Position 1800 kg - Description	<a href="#">DA50-A-15-62-09-02A-040A-D</a>	09-09-2021

Document title	Data Module Code	Issue date
Landing Distances - Abnormal Flap Position 1600 kg - Description	DA50-A-15-62-09-03A-040A-D	09-09-2021
Go-Around Climb Performance - Description	DA50-A-15-62-07-00A-040A-D	26-08-2020
Go-Around Climb Performance 1999 kg - Description	DA50-A-15-62-07-01A-040A-D	06-05-2022
Go-Around Climb Performance 1800 kg - Description	DA50-A-15-62-07-02A-040A-D	06-05-2022
Go-Around Climb Performance 1600 kg - Description	DA50-A-15-62-07-03A-040A-D	06-05-2022
Glide - Description	DA50-A-15-62-10-00A-040A-D	28-05-2021
Approved Noise Data - Description	DA50-A-15-61-06-00A-040A-D	06-12-2023
General - Description	DA50-A-15-81-00-01A-040A-D	26-08-2020
Datum Plane - Description	DA50-A-15-81-06-00A-040A-D	28-05-2021
Mass and Balance Report - Description	DA50-A-15-81-00-00A-040A-D	26-08-2020
Flight Mass and Center of Gravity - Description	DA50-A-15-81-03-01A-040A-D	25-05-2021
Moment Arms - Description	DA50-A-15-81-01-00A-040A-D	27-10-2021
Loading Diagram - Description	DA50-A-15-81-02-00A-040A-D	28-05-2021
Calculation of Loading Condition - Description	DA50-A-15-81-03-00A-040A-D	09-09-2021
Permissible Center of Gravity Range - Description	DA50-A-15-81-04-00A-040A-D	28-05-2021
Permissible Moment Range - Description	DA50-A-15-81-05-00A-040A-D	28-05-2021
Equipment - Description	DA50-A-15-82-00-00A-040A-D	06-12-2023
Airframe - Description	DA50-A-51-00-00-99A-040A-D	26-08-2020
Flight Controls - Description	DA50-A-27-00-00-99A-040A-D	26-08-2020
Ailerons - Description	DA50-A-27-10-00-99A-040A-D	26-08-2020
Flaps - Description	DA50-A-27-50-00-99A-040A-D	28-05-2021
Rudder - Description	DA50-A-27-20-00-98A-040A-D	26-08-2020
Elevator - Description	DA50-A-27-30-00-99A-040A-D	28-05-2021
Elevator Trim - Description	DA50-A-27-30-01-99A-040A-D	26-08-2020
Rudder Trim - Description	DA50-A-27-20-01-99A-040A-D	28-05-2021
Rudder Pedal - Description	DA50-A-27-20-00-99A-040A-D	28-05-2021
Instrument Panel - Description	DA50-A-31-10-00-99A-040A-D	28-05-2021
Landing Gear - Description	DA50-A-32-00-00-99A-040A-D	28-05-2021
Hydraulic Gear Extension System Schematic - Description	DA50-A-32-30-00-99A-040A-D	09-09-2021
Brake System - Description	DA50-A-32-40-30-99A-040A-D	06-12-2023
Crew Seat - Description	DA50-A-25-10-00-01A-040A-D	28-05-2021
LH/RH Pilot Door - Description	DA50-A-52-10-00-98A-040A-D	28-05-2021
Passenger Door - Description	DA50-A-52-10-00-99A-040A-D	28-05-2021
Emergency Exit Window - Description	DA50-A-56-10-00-99A-040A-D	08-07-2022
Egress Hammer - Description	DA50-A-25-00-00-01A-040A-D	26-08-2020
Heating and Ventilation - Description	DA50-A-21-40-00-00A-040A-D	28-05-2021
Engine, General - Description	DA50-A-72-00-00-99A-040A-D	28-05-2021



Document title	Data Module Code	Issue date
Propeller - Description	DA50-A-61-00-00-99A-040A-D	28-05-2021
Propeller Control - Description	DA50-A-61-20-00-99A-040A-D	13-02-2023
Engine Operating Controls - Description	DA50-A-76-00-99-00A-040A-D	09-09-2021
Engine Instruments - Description	DA50-A-77-00-00-99A-040A-D	09-09-2021
Cooling System - Description	DA50-A-75-20-00-99A-040A-D	16-05-2022
Turbo-Charger System - Description	DA50-A-81-20-00-99A-040A-D	27-10-2021
FADEC - Description	DA50-A-24-00-99-01A-040A-D	28-05-2021
Fuel System - Description	DA50-A-28-00-99-00A-040A-D	16-05-2022
Fuel Pumps - Description	DA50-A-28-00-99-01A-040A-D	28-05-2021
Fuel Valve - Description	DA50-A-28-00-99-02A-040A-D	16-05-2022
Fuel Tanks - Description	DA50-A-28-00-99-03A-040A-D	28-05-2021
Fuel Level Check Tool - Description	DA50-A-28-40-00-99A-040A-D	18-08-2022
Electrical System - Description	DA50-A-24-00-99-00A-040A-D	09-09-2021
Standby Attitude Module - Description	DA50-A-34-20-00-01A-040A-D	26-08-2020
Crew Alerting System (CAS) - Description	DA50-A-24-00-99-02A-040A-D	28-05-2021
Garmin G1000 NXi Integrated Avionics System - Description	DA50-A-31-40-99-00A-040A-D	26-08-2020
Primary Flight Display (PFD) - Description	DA50-A-31-40-99-01A-040A-D	26-08-2020
Multi-Function Display (MFD) - Description	DA50-A-31-40-99-02A-040A-D	28-05-2021
Audio Panel - Description	DA50-A-31-40-99-03A-040A-D	26-08-2020
Attitude and Heading Reference System (AHRS) - Description	DA50-A-31-40-99-04A-040A-D	26-08-2020
Air Data Computer (ADC) - Description	DA50-A-31-40-99-05A-040A-D	26-08-2020
PFD / MFD Control Unit (KEYPAD) - Description	DA50-A-31-40-99-06A-040A-D	13-04-2021
Autopilot GFC700 - Description	DA50-A-22-10-00-99A-040A-D	09-09-2021
Pitot-Static System - Description	DA50-A-34-10-01-00A-040A-D	26-08-2020
Stall Warning System - Description	DA50-A-34-10-00-01A-040A-D	28-05-2021
Baggage Compartment - Description	DA50-A-25-50-00-99A-040A-D	09-09-2021
Trim Weight - Description	DA50-A-53-10-00-99A-040A-D	27-10-2021
General - Description	DA50-A-15-37-00-00A-040A-D	26-08-2020
Airplane Inspection Intervals - Description	DA50-A-15-37-00-01A-040A-D	26-08-2020
Airplane Alterations or Repairs - Description	DA50-A-15-37-00-02A-040A-D	26-08-2020
Refueling - Handling	DA50-A-15-37-01-00A-170A-D	26-08-2020
Engine Oil Level Check - Handling	DA50-A-15-37-01-01A-170A-D	26-08-2020
Gearbox Oil Level Check - Handling	DA50-A-15-37-01-02A-170A-D	28-05-2021
Tire Inflation Pressure Check - Handling	DA50-A-15-37-01-03A-170A-D	09-09-2021
Ground Handling - Description	DA50-A-15-37-02-00A-040A-D	04-07-2022
Parking - Description	DA50-A-15-37-02-01A-040A-D	04-07-2022

<b>Document title</b>	<b>Data Module Code</b>	<b>Issue date</b>
Mooring - Description	<a href="#">DA50-A-15-37-02-02A-040A-D</a>	26-08-2020
Jacking - Description	<a href="#">DA50-A-15-37-02-03A-040A-D</a>	26-08-2020
Cleaning and Care - Description	<a href="#">DA50-A-15-37-03-00A-040A-D</a>	28-05-2021
Cleaning the Aircraft from Ice and Snow - Description	<a href="#">DA50-A-15-37-04-00A-040A-D</a>	08-06-2022
Supplements - Description	<a href="#">DA50-A-00-40-00-07A-040A-D</a>	13-02-2023

## LIST OF FIGURES

Figure	Title	Page
<b>01 - General</b>		
1	Three-View Drawing .....	01-13
<b>02 - Operating Limitations</b>		
1	Permissible Center of Gravity Range .....	02-9
2	Limitation Placards 1 .....	02-16
3	Limitation Placards 2 .....	02-17
4	Limitation Placards 3 .....	02-18
5	Limitation Placards 4 .....	02-19
6	Limitation Placards 5 .....	02-20
7	Limitation Placards 6 .....	02-21
8	Limitation Placards 5 .....	02-21
9	Limitation Placards 8 (if Tablet Mount is installed) .....	02-22
<b>05 - Performance</b>		
<b>Performance General</b>		
1	International Standard Atmosphere .....	05-7
2	Wind Components Diagram .....	05-9
<b>Climb Performance Take Off Climb</b>		
1	Gradient Formula .....	05-23
<b>Climb Performance Cruise Climb</b>		
1	Gradient Formula .....	05-28
<b>Go Around Climb Performance</b>		
1	Gradient Formula .....	05-57
<b>06 - Mass and Balance / Equipment</b>		
<b>Mass and Balance</b>		
1	Datum Plane .....	06-4
2	Loading Diagram .....	06-9
3	Permissible Center of Gravity Range .....	06-14
4	Permissible Moment Range .....	06-15
<b>07 - Description of the Airplane and its Systems</b>		
<b>Instrument Panel</b>		
1	Instrument Panel .....	07-14
<b>Landing Gear</b>		
1	Extension of the Landing Gear .....	07-19
2	Landing Gear Extended .....	07-20
3	Retraction of the Landing Gear .....	07-21

<b>Figure</b>	<b>Title</b>	<b>Page</b>
4	Landing Gear Retracted .....	07-22
5	Emergency Extension of the Landing Gear .....	07-23
6	Brake System Functional Diagram .....	07-25
<b>Seats and Safety Harnesses</b>		
1	Pilots Seat .....	07-28
<b>Doors and Interior</b>		
1	Emergency Exit Window .....	07-33
<b>Powerplant</b>		
1	Propeller Setpoint Curve .....	07-41
2	G1000 NXi Engine page .....	07-45
3	G1000 NXi Full Engine Page .....	07-46
4	Liquid Cooling System Schematic Diagram .....	07-48
5	Turbo-Charger System Schematic .....	07-50
<b>Fuel System</b>		
1	Fuel System .....	07-54
2	Schematic Normal Fuel Supply .....	07-57
3	Schematic Emergency Fuel Supply .....	07-58
4	Fuel Level Check Tool .....	07-63
5	Fuel Level Check Tool on Wing .....	07-64
<b>Electrical Systems</b>		
1	Electrical System .....	07-68
<b>Garmin G1000 NXI</b>		
1	Primary Flight Display .....	07-75
<b>Baggage Compartment</b>		
1	Baggage Compartment I .....	07-93
2	Baggage Compartment II .....	07-94
3	Baggage Compartment III .....	07-95
4	Front Barrier and Baggage Tray Step .....	07-96
<b>08 - Airplane Handling, Care and Maintenance</b>		
<b>Ground Handling</b>		
1	Steering Bar .....	08-14
2	Gust Lock Installation .....	08-16

**00**  
**FRONT MATTER**

## 00-01 Certification Basis

### Description

#### 1 Certification Basis

##### CAUTION

THE DA 50 C IS A SINGLE ENGINE AIRPLANE. WHEN THE OPERATING LIMITATIONS AND MAINTENANCE REQUIREMENTS ARE COMPLIED WITH, IT HAS THE HIGH DEGREE OF RELIABILITY, WHICH IS REQUIRED BY THE CERTIFICATION BASIS. NEVERTHELESS, AN ENGINE FAILURE IS NOT COMPLETELY IMPOSSIBLE. FOR THIS REASON, FLIGHTS DURING THE NIGHT, ON TOP, UNDER INSTRUMENT METEOROLOGICAL CONDITIONS (IMC), OR ABOVE TERRAIN WHICH IS UNSUITABLE FOR A LANDING, CONSTITUTE A RISK. IT IS THEREFORE HIGHLY RECOMMENDED TO SELECT FLIGHT TIMES AND FLIGHT ROUTES SUCH THAT THIS RISK IS MINIMIZED.

The certification basis is CS-23 including Amdt. 4, published on 15-Jul-2015 and additional requirements as laid down in CRI A-01 and published in the Type Certificate Data Sheet.

## 00-02 List of Incorporated AFM Changes

### Change record

#### 1 List of Incorporated AFM Changes

##### 1 Issue 1

Basic Manual

Issue date: 26-Aug-2020

##### 2 Issue 2

Following changes are incorporated in Issue 2

Change	Title
MÄM	
50-013	Baggage Compartment
50-033	Stall Warning Improvement
50-064	Engine restart envelope expansion
50-065	9.01.01-E AFM Rev.1
50-072	Emergency Exit at PAX
50-099	AFM. Ground Idle / Flight Idle
OÄM	
50-014	Sun Visor
50-018	Installation of Armrest with Integrated Key-Pad
50-020	Tablet Mount on A-Column
50-035	Removable RH Control Stick

**Table 1 - Issue 2 Changes**

The technical content of Issue 2 has been approved under the authority of the DOA ref. EASA.21J.052.

Issue date: 28-May-2021

### 3 Issue 3

Following changes are incorporated in Issue 3

Change	Title
MÄM	
50-117	AFM Landing Distance - Imperial Values
50-118	AFM Doc. No. 9.01.01-E Issue 3
OÄM	
50-006	Avidyne TAS 605A Series
50-009	Electronic Stability and Protection
50-010	GSR 56 Satellite Receiver
50-013	WX-500 Stormscope
50-031	GFC 700 Autopilot

**Table 2 - Issue 3 Changes**

The technical content of Issue 3 has been approved under the authority of the DOA ref. EASA.21J.052.

Issue date: 15-Jul-2021

### 4 Issue 4

Following changes are incorporated in Issue 4

Change	Title
MÄM	
50-135	Cylinder crankcase with cast-in gray iron liners
50-141	AFM Doc. No. 9.01.01-E Issue 4
OÄM	

**Table 3 - Issue 4 Changes**

The technical content of Issue 4 has been approved under the authority of the DOA ref. EASA.21J.052.

Issue date: 25-Aug-2021



**5 Issue 5**

Following changes are incorporated in Issue 5

Change	Title
MÄM	
50-136	No. 3 Jet Fuel
50-145	AFM Doc. No. 9.01.01-E Issue 5
OÄM	
50-003	ADF Installation

**Table 4 - Issue 5 Changes**

The technical content of Issue 5 has been approved under the authority of the DOA ref. EASA.21J.052.

Issue date: 09-Sep-2021

**6 Issue 6**

Following changes are incorporated in Issue 6

Change	Title
MÄM	
50-133	Trim Mass in Ventral Fin
50-157	AFM Doc. No. 9.01.01-E Issue 6
OÄM	
50-001	Oxygen System

**Table 5 - Issue 6 Changes**

The technical content of Issue 6 has been approved under the authority of the DOA ref. EASA.21J.052.

Issue date: 27-Oct-2021

**7 Issue 7**

Following changes are incorporated in Issue 7

Change	Title
MÄM	
50-097	Exhaust System Modification
50-148	Use of PED
50-166	AFM Doc. No. 9.01.01-E Issue 7
50-175	Power Lever Marking Harmonization
OÄM	
50-032	Flight Stream 510

**Table 6 - Issue 7 Changes**

The technical content of Issue 7 has been approved under the authority of the DOA ref. EASA.21J.052.

Issue date: 27-Jan-2022

**8 Issue 8**

Following changes are incorporated in Issue 8

Change	Title
MÄM	
50-140	Garmin GMU 44B
50-188	Recording of Oxygen System Components
50-191	Climb Performance
50-200	AFM Doc. No. 9.01.01-E Issue 8
50-202	Various Corrections
50-221	Intake Air Temperature Warning G1000
OÄM	
50-002	RACC III Installation

**Table 7 - Issue 8 Changes**

The technical content of Issue 8 has been approved under the authority of the DOA ref. EASA.21J.052.

Issue date: 18-May-2022

**9 Issue 9**

Following changes are incorporated in Issue 9

Change	Title
MÄM	
50-229	Cleaning from Ice and Snow
50-238	AFM Doc. No. 9.01.01-E Issue 9
OÄM	
50-011	Ice Protection System for flights into known icing

**Table 8 - Issue 9 Changes**

The technical content of Issue 9 has been approved under the authority of the DOA ref. EASA.21J.052.

Issue date: 14-Jun-2022

**10 Issue 10**

Following changes are incorporated in Issue 10

Change	Title
MÄM	
50-138	Gust Lock Provisions
50-201	Emergency Exit Unauthorized Entry Protection Information
50-232	PST300-AR-2 Pitot Static Probe
50-248	AFM Doc. No. 9.01.01-E Issue 10

**Table 9 - Issue 10 Changes**

The technical content of Issue 10 has been approved under the authority of the DOA ref. EASA.21J.052.

Issue date: 16-Aug-2022

**11 Issue 11**

Following changes are incorporated in Issue 11

Change	Title
MÄM	
50-199	Jet A Fuel (ASTM D1655)
50-217	AFM - Doc. No. 9.01.01-E Incorporation of FAA Comments
50-259	Fuel Level Check Tool Information
50-270	Consolidation of Limitation Placard
50-282	AFM Doc. No. 9.01.01-E Issue 11
OÄM	
50-002/g	RACC III Installation
50-011/n	Ice Protection System (TKS)
50-048	GDC72 New Part Number

**Table 10 - Issue 11 Changes**

The technical content of Issue 11 has been approved under the authority of the DOA ref. EASA.21J.052.

Issue date: 14-Dec-2022

**12 Issue 12**

Following changes are incorporated in Issue 12

Change	Title
MÄM	
50-295	Engine Mapping V28D112DA50
50-325	AFM Doc. No. 9.01.01-E Issue 12
NÄM	
50-022	Operation in China
OÄM	
50-047	Business Seating Pax Row 1

**Table 11 - Issue 12 Changes**

The technical content of Issue 12 has been approved under the authority of the DOA ref. EASA.21J.052.

Issue date: 13-Feb-2023

**13 Issue 13**

Following changes are incorporated in Issue 13

Change	Title
MÄM	
50-326	New Fire Extinguisher
50-328	AFM - Cross Wind Component
50-333	AFM - Correction of Noise Data Requirement Reference
50-362	AFM Doc. No. 9.01.01-E Issue 13
OÄM	

**Table 12 - Issue 13 Changes**

The technical content of Issue 13 has been approved under the authority of the DOA ref. EASA.21J.052.

Issue date: 26-Jun-2023

**14 Issue 14**

Following changes are incorporated in Issue 14

Change	Title
MÄM	
50-110	Turbocharger Interface Change
50-347	AFM - 2nd Alternator Function Test Procedure
50-390	AFM CS - Removal of Exhaust Part Number
50-415	AFM Doc. No. 9.01.01-E Issue 14
OÄM	
50-027/a	GDL 69A
50-037	GTX345R Transponder new part number
50-056	GIA64W new part number

**Table 13 - Issue 14 Changes**

The technical content of Issue 14 has been approved under the authority of the DOA ref. EASA.21J.052.

Issue date: 06-Dec-2023

**01**  
**GENERAL**

## 01-01 AFM Introduction

### Description

#### 1 Introduction

This Airplane Flight Manual has been prepared in order to provide pilots and instructors with all the information required for the safe and efficient operation of the airplane.

The Airplane Flight Manual includes all the data which must be made available to the pilot according to the CS-23 requirements. Beyond this, it contains further data and operating instructions which, in the manufacturer's opinion, could be of value to the pilot.

Equipment and modification level (design details) of the airplane may vary from serial number to serial number. Therefore, some of the information contained in this manual is applicable depending on the respective equipment and modification level. The exact equipment of your serial number is recorded in section [06-10 - Equipment - Description](#). The modification level is recorded in the following table (as far as necessary for this manual).

Modification	Source	Installed	
		<input type="checkbox"/> yes	<input type="checkbox"/> no
Turbo Charger Interface Change	MÄM 50-110	<input type="checkbox"/> yes	<input type="checkbox"/> no
Installation of Armrest with Integrated Key-Pad	OÄM 50-018	<input type="checkbox"/> yes	<input type="checkbox"/> no
Tablet Mount on A-Column	OÄM 50-020	<input type="checkbox"/> yes	<input type="checkbox"/> no

**Table 1 - Modification Level**

This Airplane Flight Manual must be kept on board the airplane at all times. Its designated place is the bag on the rear side of the forward right seat. The designated place for the Garmin G1000 NXi Cockpit Reference Guide is the bag on the rear side of the forward left seat. If AFM and GCRG are combined in one folder, the designated place is the bag on the rear side of the forward right seat.

## 01-02 Warnings, Cautions and Notes

### Description

#### 1 Warnings, Cautions and Notes

##### **WARNING**

MEANS THAT THE NON-OBSERVATION OF THE CORRESPONDING PROCEDURE LEADS TO AN IMMEDIATE OR IMPORTANT DEGRADATION IN FLIGHT SAFETY.

##### **CAUTION**

MEANS THAT THE NON-OBSERVATION OF THE CORRESPONDING PROCEDURE LEADS TO A MINOR OR TO A MORE OR LESS LONG TERM DEGRADATION IN FLIGHT SAFETY.

##### **NOTE**

Draws the attention to any special item not directly related to safety but which is important or unusual.

Special statements in the Airplane Flight Manual concerning the safety or operation of the airplane are highlighted by being prefixed by one of the terms.



## 01-03 Dimensions and areas

### Description

#### 1 Dimensions

The DA 50 C uses the System Internationale (SI) for dimensions and areas. Imperial dimensions are also given in brackets. For example: Wing span 13.41 m (44 ft).

DA 50 C Dimensions	
<b>Overall Dimensions</b>	
Wing span	13.41 m (44 ft)
Length	9.239 m (30.31 ft)
Height	2.953 m (9.69 ft)
<b>Wing</b>	
Airfoil	Wortmann FX 63-137/20-W4
Area	16.43 m <sup>2</sup> (176.85 ft <sup>2</sup> )
Dihedral	5.5°
Aspect ratio	11.0
Leading edge sweep back	1°
MAC	1.274 m (4.18 ft)
Geometrical twist	-2.2°
<b>Flaps</b>	
Span	2 x 4.210 m (13.81 ft)
Area	2 x 1.385 m <sup>2</sup> (14.91 ft <sup>2</sup> )
<b>Aileron</b>	
Span	2 x 1.669 m (5.48 ft)
Area	2 x 0.325 m <sup>2</sup> (3.50 ft <sup>2</sup> )
<b>Horizontal Stabilizer</b>	
Span	4.130 m (13.55 ft)
Area (incl. elevator, tips and trim tab)	3.14 m <sup>2</sup> (33.80 ft <sup>2</sup> )
HT tips area	0.129 m <sup>2</sup> (1.389 ft <sup>2</sup> )
Aspect ratio	5.433
Leading edge sweep back	12.4°
Airfoil	FX 71-L-150/30
<b>Elevator</b>	
Span	2.95 m (9.68 ft)

Table 1 - DA 50 C Dimensions

DA 50 C Dimensions	
Area	0.84 m <sup>2</sup> (9.04 ft <sup>2</sup> )
<b>Elevator Trim Tab</b>	
Span	1.140 m (3.74 ft)
Area	0.099 m <sup>2</sup> (1.07 ft <sup>2</sup> )
<b>Vertical Stabilizer</b>	
Span	1.719 m (5.64 ft)
Area	2.435 m <sup>2</sup> (26.21 ft <sup>2</sup> )
Leading edge sweep back	34°
Airfoil	FX 71-L-150/30
<b>Rudder</b>	
Span	1.677 m (5.50 ft)
Area (incl. rudder trim tab)	0.748 m <sup>2</sup> (8.05 ft <sup>2</sup> )
<b>Rudder Trim Tab</b>	
Span	0.717 m (2.35 ft)
Area (incl. rudder trim tab)	0.049 m <sup>2</sup> (0.53 ft <sup>2</sup> )
<b>Landing Gear</b>	
Wheel track	2.87 m (9.41 ft)
Wheel base (unloaded)	2.77 m (9.08 ft)
<b>Main Wheel</b>	
Tire	6.00-6, for details refer to AMM
Tire inflation pressure (unloaded)	3.8 bar (55 psi)
Damper gas pressure (unloaded)	20 bar (290 psi)
<b>Nose Wheel</b>	
Tire	5.00-5, for details refer to AMM
Tire inflation pressure (unloaded)	6.1 bar (88.5 psi)
Damper gas pressure (unloaded)	8 bar (116 psi)

Table 1 - DA 50 C Dimensions

## 01-04 Acronyms

### Description

## 1 Acronyms

### Airspeeds

IAS	Indicated Airspeed as shown on an airspeed indicator.
KCAS	Calibrated Airspeed in knots. Indicated airspeed, corrected for installation and instrument errors. Calibrated Airspeed equals TAS at standard atmospheric conditions (ISA) at MSL.
KIAS	IAS in knots.
TAS	True Airspeed. The speed of the airplane relative to the air. TAS is CAS corrected for errors due to altitude and temperature.
$V_O$	Operating Maneuvering Speed. Full or abrupt control surface movement is not permissible above this speed.
$V_{FE}$	Maximum Flaps Extended Speed. This speed must not be exceeded with the given flap setting.
$V_{LE}$	Maximum Landing Gear Extended Speed. This speed may not be exceeded if the landing gear is extended.
$V_{LOE}$	Maximum Landing Gear Operating Speed for Extension. This speed may not be exceeded during the extension of the landing gear.
$V_{LOR}$	Maximum Landing Gear Operating Speed for Retraction. This speed may not be exceeded during the retraction of the landing gear.
$V_{NE}$	Never Exceed Speed in smooth air. This speed must not be exceeded in any operation.
$V_{NO}$	Maximum Structural Cruising Speed. This speed may be exceeded only in smooth air, and then only with caution.
$V_R$	Rotation Speed.
$V_{SO}$	Stalling Speed, or the minimum continuous speed at which the airplane is still controllable in the landing configuration.
$V_{S1}$	Stalling Speed, or the minimum continuous speed at which the airplane is still controllable in the given configuration.
$V_x$	Best Angle-of-Climb Speed.
$V_y$	Best Rate-of-Climb Speed.
$V_{50ft}$	Speed at 50 ft above take-off surface.

### Meteorological Terms

ISA	International Standard Atmosphere. Conditions at which air is identified as an ideal dry gas. The temperature at mean sea level is 15 °C (59 °F), air pressure at MSL is 1013.25 hPa (29.92 inHg); the temperature gradient up to the altitude at which the temperature
-----	---

reaches  $-56.5^{\circ}\text{C}$  ( $-69.7^{\circ}\text{F}$ ) is  $-0.0065^{\circ}\text{C/m}$  ( $-0.00357^{\circ}\text{F/ft}$ ), and above this  $0^{\circ}\text{C/m}$  ( $0^{\circ}\text{F/ft}$ ).

MSL	Mean Sea Level.
OAT	Outside Air Temperature.
QNH	Theoretical atmospheric pressure at MSL, calculated from the elevation of the measuring point above MSL and the actual atmospheric pressure at the measuring point.
Density Altitude	Altitude in ISA conditions at which the air density is equal to the current air density.
Indicated Pressure Altitude	Altitude reading with altimeter set to 1013.25 hPa (29.92 inHg).
Pressure Altitude	Altitude indicated by a barometric altimeter, which is set to 1013.25 hPa (29.92 inHg). The Pressure Altitude is the Indicated Pressure Altitude corrected for installation and instrument errors. In this Airplane Flight Manual altimeter instrument errors are regarded as zero.
Wind	The wind speeds which are shown as variables in the diagrams and tables in this manual should be regarded as headwind or tailwind components of the measured wind.

### Flight Performance and Flight Planning

AGL	Above Ground Level.
Demonstrated Crosswind Component	The speed of the crosswind component at which adequate maneuverability for take-off and landing has been demonstrated during type certification.
MET	Weather, weather advice.
NAV	Navigation, route planning.
RoC	Rate of Climb.

### Mass and Balance

CG	Center of Gravity, also called 'center of mass'. Imaginary point in which the airplane mass is assumed to be concentrated for mass and balance calculations. Its distance from the Datum Plane is equal to the Center of Gravity Moment Arm.
Center of Gravity Moment Arm	The Moment Arm which is obtained if one divides the sum of the individual moments of the airplane by its total mass.
Center of Gravity Limits	The Center of Gravity range within which the airplane, at a given mass, must be operated.
DP	Datum Plane; an imaginary vertical plane from which all horizontal distances for center of gravity calculations are measured.
Empty Mass	The mass of the airplane including unusable fuel, all operating fluids and the maximum quantity of oil.
Maximum Take-off Mass	The maximum permissible mass for take-off.
Maximum Landing Mass	The highest mass for landing conditions at the maximum descent velocity. This velocity was used in the strength calculations to determine the landing gear loads during a particularly hard landing.

Moment Arm	The horizontal distance from the Datum Plane to the Center of Gravity of a component.
Moment	The mass of a component multiplied by its moment arm.
Usable Fuel	The quantity of fuel available for flight planning.
Unusable Fuel	The quantity of fuel remaining in the tank which cannot be used for flight.
Useful load	The difference between take-off mass and empty mass.

### Designation of the Circuit Breakers on the Instrument Panel

#### Essential Bus

SAM	Standby Altitude Module
AHRS	Attitude Heading Reference System
COM1	COM Radio No. 1
GPS/NAV1	Global Positioning System and NAV Receiver No. 1
ADC	Air Data Computer
ENG INST	Engine Instruments
XPDR	Transponder
FLAPS	Flap System
PITOT	Pitot Heating System
LANDING	Landing Light
FLOOD	Flood Light
GEAR WARN	Landing Gear Annunciation
PFD	Primary Flight Display
MASTER CTRL.	Master Control (Essential Tie Relay/Avionic Master Relay)
ESS TIE	Essential Tie Relay
BATT	Battery

#### Main Bus

COWL FLAP	Cowl flap system
AV/GDU FAN	Avionic-, GDU-Cooling Fans
GEAR	Landing Gear Control
AV BUS	Avionics Bus
MFD	Multi Function Display
STROBE	Anti Collision Light
POSITION	Position Light
TAXI/MAP	Taxi-, Map-Light
INST.LT	Instrument Light
XFR PUMP	Fuel Transfer Pump
GCU / FLT STRM	Control Unit (Keypad) / Flight Stream

STALL/STATIC HT. Stall Warning/Static Heating System

RUDDER TRIM Rudder Trim System

AIR CTRL. ECS Fan

ALT1 Alternator 1

ALT2 Alternator 2

ECS ECS Control

MAIN TIE Main Tie Relay

USB PORTS USB Ports

PEDALS Adjustable Rudder Pedals

#### **Avionics Bus**

TAS Traffic Advisory System

ADF Automatic Direction Finder

IRIDIUM Satellite Receiver

COM2 COM Radio No. 2

GPS/NAV2 Global Positioning System and NAV Receiver No. 2

AUDIO Audio Panel

AFCS/ESP Auto Pilot System

DME Distance Measuring Equipment

TWX Lightning Detection System

DATA LINK Data Link System

#### **For the engine**

ECU A Engine Control Unit A

ECU B Engine Control Unit B

MAIN PUMP Main Fuel Pump

EMERG PUMP Emergency Fuel Pump

#### **Equipment**

ELT Emergency Locator Transmitter

#### **Design Change Advisories**

MÄM Mandatory Design Change Advisory

OÄM Optional Design Change Advisory

VÄM Variant Design Change Advisory

#### **Miscellaneous**

AC Advisory Circular

AFM Airplane Flight Manual

---

AMC	Acceptable Means of Compliance
AMM	Airplane Maintenance Manual
AIRAC	Aeronautical Information Regulation and Control
ATC	Air Traffic Control
B-RNAV	Basic Area Navigation
CAS	Crew Alerting System
CFRP	Carbon Fiber Reinforced Plastic
EASA	European Aviation Safety Agency
EFB	Electronic Flight Bag
EGNOS	European Geostationary Navigation Overlay Service
EPU	External Power Unit
ETSO	European Technical Standard Order
GIA	Garmin Integrated Avionics
GFRP	Glass Fiber Reinforced Plastic
GNSS	Global Navigation Satellite System
GPS	Global Positioning System
IFR	Instrument Flight Rules
IPL	Interference Path Loss
LNAV+V	Lateral Navigation with Advisory Vertical Guidance
LNAV/VNAV	Lateral Navigation / Vertical Navigation
LPV	Localizer Performance with Vertical Guidance
MAC	Mean Aerodynamical Chord
MSAS	Multi-functional Satellite Augmentation System
PCA	Primary Certification Authority
PED	Portable Electronic Device
P-RNAV	Precision Area Navigation
RAIM	Receiver Autonomous Integrity Monitoring
RNAV	Area Navigation
RNP	Required Navigation Performance
SBAS	Satellite Based Augmentation System
SID	Standard Instrument Departure
STAR	Standard Terminal Arrival Route
T-PED	Transmitting Portable Electronic Device
VFR	Visual Flight Rules
WAAS	Wide Area Augmentation System
WFDE	WAAS Fault Detection/Exclusion

## 01-05 Conversion Factors

### Description

#### 1 Conversion Factors

Dimension	SI-Units	US-Units	Conversion
Length	[mm] millimeters	[in] inches	$[mm] / 25.4 = [in]$
	[m] meters	[ft] feet	$[m] / 0.3048 = [ft]$
	[km] kilometers	[NM] nautical miles	$[km] / 1.852 = [NM]$
Volume	[l] liters	[US gal] US gallons	$[l] / 3.7854 = [US\ gal]$
		[qts] US quarts	$[l] / 0.9464 = [qts]$
	[ml] milliliter	[oz] ounce	$[ml] \times 0.033814 = [oz]$
Speed	[km/h] kilometers per hour	[kts] knots	$[km/h] / 1.852 = [kts]$
		[mph] miles per hour	$[km/h] / 1.609 = [mph]$
	[m/s] meters per second	[fpm] feet per minute	$[m/s] \times 196.85 = [fpm]$ $[fpm] / 196.85 = [m/s]$
Speed of rotation	[RPM] revolutions per minute		-
Mass	[kg] kilograms	[lb] pounds	$[kg] \times 2.2046 = [lb]$
Force, weight	[N] newtons	[lbf] pounds force	$[N] \times 0.2248 = [lbf]$
Pressure	[hPa] hectopascals	[inHg] inches of mercury	$[hPa] = [mbar]$
	[mbar] millibars		$[hPa] / 33.86 = [inHg]$
	[bar] bars	[psi] pounds per square inch	$[bar] \times 14.504 = [psi]$
Temperature	[°C] degrees Celsius	[°F] degrees Fahrenheit	$[°C] \times 1.8 + 32 = [°F]$ $([°F] - 32) / 1.8 = [°C]$
Intensity of electric current	[A] ampères		-
Electric charge (battery capacity)	[Ah] ampère-hours		-
Electric potential	[V] volts		-
Time	[sec] seconds		-

**Table 1 - Conversion Factors**



Liters	US Gallons		US Gallons	Liters
5	1.3		1	3.8
10	2.6		2	7.6
15	4.0		4	15.1
20	5.3		6	22.7
25	6.6		8	30.3
30	7.9		10	37.9
35	9.2		12	45.4
40	10.6		14	53.0
45	11.9		16	60.6
50	13.2		18	68.1
60	15.9		20	75.7
70	18.5		22	83.3
80	21.1		24	90.9
90	23.8		26	98.4
100	26.4		28	106.0
110	29.1		30	113.6
120	31.7		32	121.1
130	34.3		34	128.7
140	37.0		36	136.3
150	39.6		38	143.8
160	42.3		40	151.4
170	44.9		45	170.3
180	47.6		50	189.3

Table 2 - Conversion Chart Liters / US Gallons

# 01-06 Three-View Drawing Description

## 1 Three-View Drawing

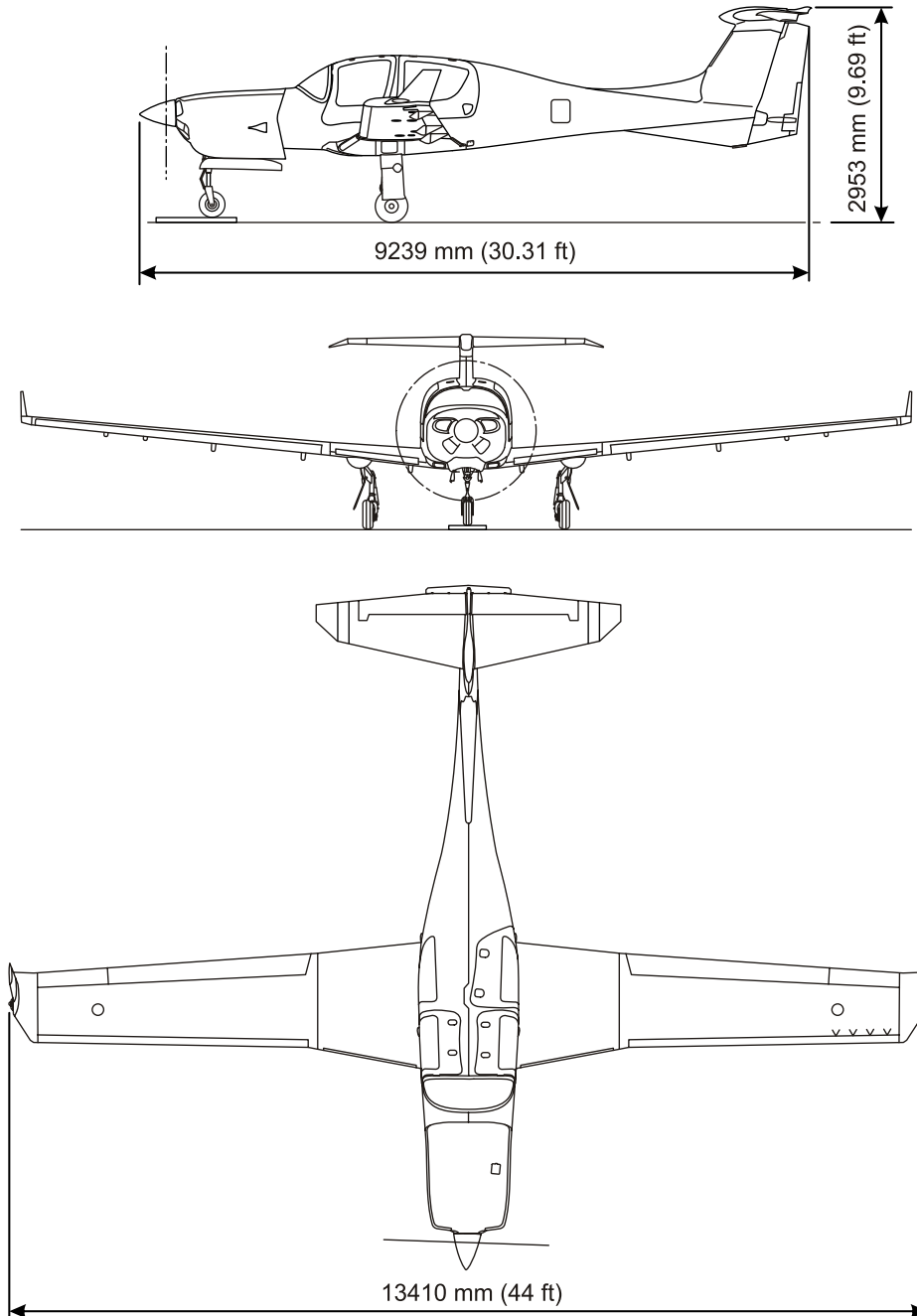

Figure 1 - Three-View Drawing

## 01-07 G1000 NXi Avionics System

### Description

#### 1 G1000 NXi Avionics System

The DA 50C airplane is equipped with a Garmin G1000 NXi Avionics System.

The Garmin GNSS navigation system installed in this airplane is a GPS system with a Satellite Based Augmentation System (SBAS) comprised of two TSO-C145a Class 3 approved Garmin GIA 64Ws, TSO-C146d Class 3 approved Garmin GDU 1050 Display Units, one Garmin GA 36 antenna, one Comant CI 2580-200 antenna, and GPS software version 5.1 or later approved version. The Garmin G1000 NXi Integrated Avionics GNSS navigation system in this airplane is installed in accordance with FAA AC 20-138D, EASA AMC 20-28 and EASA AMC 20-27.

#### NOTE

The following listing of the Garmin G1000 NXi operational capabilities does not constitute an operational approval. For the operational approval of the aircraft contact the appropriate governing authority.

The G1000 NXi Integrated Avionics GNSS navigation system as installed in this airplane is approved for navigation using GPS and GPS/SBAS (within the coverage of a Satellite Based Augmentation System complying with ICAO Annex 10) for IFR en-route, terminal area, non-precision approach, and approach procedures with vertical guidance operation.

The G1000 NXi Integrated Avionics GNSS navigation system as installed in this airplane complies with the equipment, performance and functional requirements to conduct RNAV and RNP operations in accordance with the applicable requirements of the reference documents listed in the following table.

Specification	Reference Document		ICAO Flight Plan Code	Integrated flight deck G1000 NXi with SBAS
	FAA	EASA or JAA		
RNAV 10 (RNP 10) Oceanic	FAA Order 8400.12B	-	A1	Yes
B-RNAV/RNAV 5 (operations in Europe)	FAA AC 90-96A CHG 1	EASA AMC 20-4	B2	Yes
RNAV 2	FAA AC 90-100A	-	C2	Yes
RNAV 1	FAA AC 90-100A	-	D2	Yes
P-RNAV (operations in Europe)	FAA AC 90-96A CHG 1	JAA TGL 10 Rev 1	D2	Yes
RNP 4 (Oceanic)	FAA Order 8400.33	-	L1	Yes
RNP 1	FAA AC 90-105	-	O2	No
RNP APCH LNAV	FAA AC 90-105	EASA AMC 20-27	S1	Yes
RNP APCH LNAV/VNAV	FAA AC 90-105	EASA AMC 20-27 with CM-AS-002	S2	Yes
LP	FAA AC 90-107	-	N/A	Yes, if GDU software version

**Table 1 - Requirements RNAV and RNP Operations**

Specification	Reference Document		ICAO Flight Plan Code	Integrated flight deck G1000 NXi with SBAS
	FAA	EASA or JAA		
				13.00 or later is installed.
LPV	FAA AC 90-107	EASA AMC 20-28	N/A	Yes
RNP AR APCH	FAA AC 90-101A	EASA 20-26	T1	No

**Table 1 - Requirements RNAV and RNP Operations**

Garmin International holds an FAA Type 2 Letter of Acceptance (LOA) in accordance with RTCA/DO-200A and AC 20-153B for database Integrity, quality, and database management processes for many of its aviation databases. Pilots and operators can view the LOA status and RTCA/DO-200A List of Applicable Avionics (190-01999-00) at [www.FlyGarmin.com](http://www.FlyGarmin.com) > Aviation Databases > Type 2 LOA Status.

Navigation information is referenced to WGS-84 reference system.

The airplane has been assessed for back door coupling susceptibility in accordance with EUROCAE ED-239 Section 3 and found PED tolerant for back door coupling. The airplane has been assessed for front door coupling susceptibility in accordance with EUROCAE ED-130A Appendix A. No IPL determination was made.

# 02 OPERATING LIMITATIONS

## 02-01 Aircraft release/operating limitations

### Description

#### 1 Aircraft Operating Limitations Introduction

##### **WARNING**

**OPERATION OF THE AIRPLANE OUTSIDE OF THE  
APPROVED OPERATING LIMITATIONS IS NOT  
PERMISSIBLE.**

Chapter 2 of this Airplane Flight Manual includes operating limitations, instrument markings, and placards necessary for the safe operation of the airplane, its power-plant, standard systems and standard equipment.

The limitations included in this Chapter are approved.

## 02-02 Airspeed Limitations

### Description

#### 1 Airspeed Limitations

	Airspeed		KIAS	Remarks
V <sub>O</sub>	Operating maneuvering speed	above 1850 kg	133 KIAS	Do not make full or abrupt control surface movement above this speed.
		above 1650 kg	125 KIAS	
		above 1480 kg	119 KIAS	
V <sub>FE</sub>	Max. flaps extended speed	T/O	133 KIAS	Do not exceed these speeds with the given flap setting.
		LDG	121 KIAS	
V <sub>NO</sub> = V <sub>C</sub>	Max. structural cruising speed		152 KIAS	Do not exceed this speed except in smooth air, and then only with caution.
V <sub>NE</sub>	Never exceed speed in smooth air		191 KIAS	Do not exceed this speed in any operation.
V <sub>LO</sub>	Max. landing gear operating speed (normal operation)		162 KIAS	Do not operate landing gear above this speed.
	Max. landing gear operating speed (emergency operation/manual extension)		102 KIAS	Do not operate landing gear above this speed.
V <sub>LE</sub>	Max. speed with landing gear extended		162 KIAS	Do not exceed this speed with the landing gear extended.

Table 1 - Airspeed Limitations

## 02-03 Airspeed Indicator Markings

### Description

#### 1 Airspeed Indicator Markings

Marking	KIAS	Significance
White arc	59 - 121	Operating range with flaps fully extended
Green arc	72 - 152	Normal operating range
Yellow arc	152 - 191	"Caution" range - only in smooth air
Red line	191	Never exceed speed in smooth air

**Table 1 - Airspeed Indicator Markings**



## 02-04 Power Plant Limitations

### Description

#### 1 Power Plant Limitations

##### 1 Engine

Manufacturer	Continental Aerospace Technologies
Type	Centurion 3.0 (CD-300)

##### 2 Engine power

Take-off power (max. 5 min)	100% 300 hp (221 kW) at 2340 Propeller RPM
Max. continuous power	90% 272 hp (200 kW) at 2300 Propeller RPM

##### 3 Propeller

Manufacturer	mt-Propeller
Type	MTV-12-D/210-56
Diameter	2.10 m

##### 4 Propeller RPM

Maximum take-off	2340 RPM
Maximum continuous	2300 RPM
Maximum overspeed (up to 20 s)	2500 RPM

##### 5 Oil pressure

Minimum	2.0 bar
Minimum (above 1800 RPM)	3.5 bar
Maximum	7.5 bar
Normal	3.5 - 7.0 bar

##### 6 Oil quantity

Normal range	10 - 12 l (as per OM)
Maximum allowed oil consumption	0.1 l/h

##### 7 Oil temperature

Minimum (maximum power)	50 °C
Maximum	125 °C

Starting min. -25 °C

#### 8 Coolant temperature

Normal operation 60 °C - 101 °C

Maximum 105 °C

Starting min. -25 °C

#### 9 Gearbox temperature

Minimum 50 °C

Maximum 110 °C

#### 10 Fuel pressure (gauge pressure)

Minimum -0.3 bar

Maximum 1.0 bar

#### 11 Fuel temperature

Minimum (during operation) -25 °C

Maximum (at engine feed pump) 60 °C

#### 12 Oil specification

AeroShell Oil Diesel Ultra

#### 13 Gearbox oil specification

CENTURION Gearbox Oil N1

#### 14 Engine starting temperature

Minimum -25 °C

#### 15 Maximum restart altitude

Maximum restart altitude 15,000 ft pressure altitude

#### 16 Restart airspeed (windmilling):

Restart airspeed 122 KIAS  
(windmilling):

#### 17 Power Setting:

Power setting below flight idle in flight is prohibited.

## 02-05 Engine Instrument Markings

### Description

### 1 Engine Instrument Markings

Engine instrument markings and their colour code significance are shown in the table below.

Indication	Red arc/bar	Yellow arc/bar	Green arc/bar	Yellow arc/bar	Red arc/bar
	lower prohibited range	caution range	normal operating range	caution range	upper prohibited range
Prop RPM	-	-	0 to 2300 RPM	2300 to 2340 RPM	above 2340 RPM
Oil pressure	0.0 to 2.0 bar	2.0 to 3.5 bar	3.5 to 7.0 bar	7.0 to 7.5 bar	max. 7.5 bar
Oil temperature	below -25 °C	-25 to 50 °C	50 to 115 °C	115 to 125 °C	above 125 °C
Coolant temperature	below -25 °C	-25 to 60 °C	60 to 101 °C	101 to 105 °C	above 105 °C
Gearbox temperature	below -25 °C	-25 to 50 °C	50 to 105 °C	105 to 110 °C	above 110 °C
Fuel temperature	below -25 °C	-25 to -20 °C	-20 to 55 °C	55 to 60 °C	above 60 °C
Fuel pressure	below -0.3 bar	-	-0.3 to 1.0 bar	-	above 1.0 bar
Fuel quantity	below 1 US gal	-	1 to 25 US gal LH 1 to 24 US gal RH	-	-
Load	-	-	up to 90%	90 - 100%	-
Amp	-	-	below 60 A	60 A to 70 A	above 70 A
Voltmeter	below 24.1 V	24.1 to 25 V	25 to 30 V	30 to 32 V	above 32 V

**Table 1 - Engine Instrument Markings**

## 02-06 Mass (Weight)

### Description

#### 1 Mass (Weight)

#### WARNING

**EXCEEDING THE MASS LIMITS WILL LEAD TO AN OVERSTRESSING OF THE AIRPLANE AS WELL AS TO A DEGRADATION OF FLIGHT CHARACTERISTICS AND FLIGHT PERFORMANCE.**

Value	Mass (Weight)	
	kg	lb
Maximum take-off mass	1999 kg	4407 lb
Minimum flight mass	1480 kg	3263 lb
Maximum zero fuel mass	1900 kg	4189 lb
Maximum landing mass	1999 kg	4407 lb
Max. load in Area A of baggage compartment	40 kg	88 lb
Max. load in Area B of baggage compartment	35 kg	77 lb
Max. load in Compartment C of baggage compartment	10 kg	22 lb
Max. load in Compartment D of baggage compartment	5 kg	11 lb

**Table 1 - Mass (Weight)**

#### NOTE

In some countries the beginning of a flight is defined by starting the engine. In those countries a maximum ramp mass 2008 kg (4427 lb) above the maximum take-off mass is approved. At the time of lift-off the maximum permitted take-off mass must not be exceeded.

#### NOTE

The maximum zero fuel mass is the highest mass with empty fuel tanks.

## 02-07 Center of Gravity Description

### 1 Centre of Gravity

The Datum Plane (DP) is located 2.196 m forward of the most forward point of the root rib on the stub wing.

The flight CG position must be within the following limits:

Most forward flight CG:

- 2.315 m aft of datum plane at 1480 kg to 1750 kg
- 2.315 m aft of datum plane at 1750, increasing linearly to (see next row)
- 2.42 m aft of datum plane at 1999 kg

Most rearward flight CG:

- 2.355 m aft of datum plane at 1480 kg, increasing linearly to (see next row)
- 2.458 m aft of datum plane at 1645 kg, increasing linearly to (see next row)
- 2.47 m aft of datum plane at 1999 kg

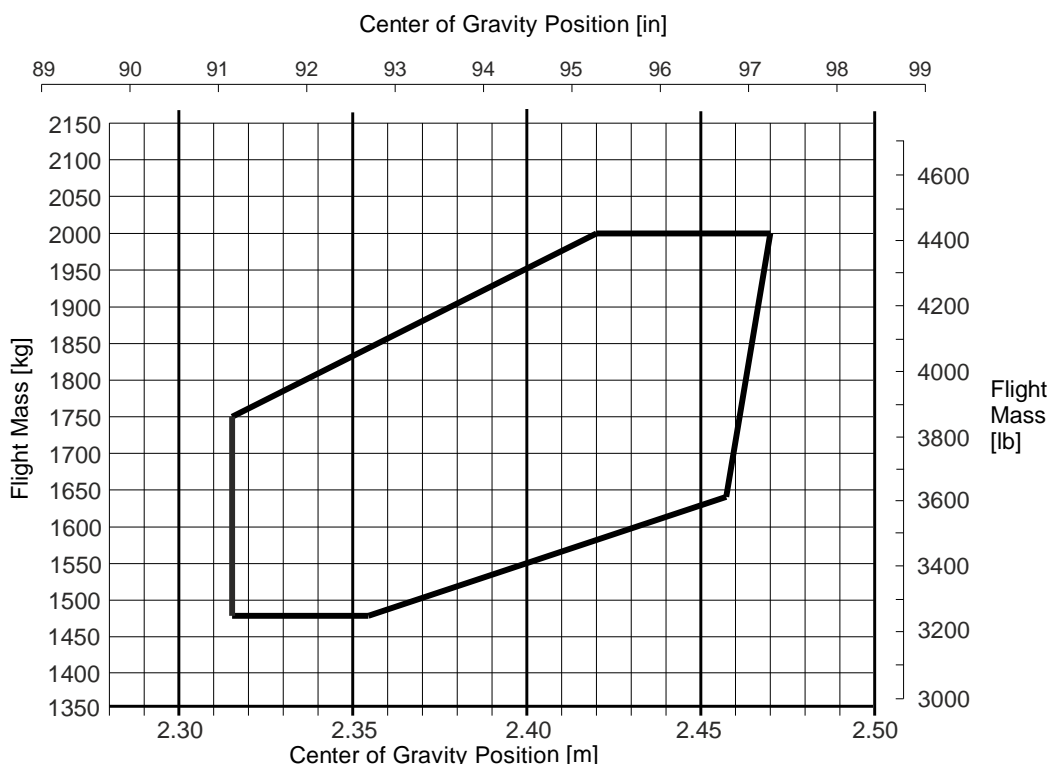

Figure 1 - Permissible Center of Gravity Range

## 02-08 Approved Maneuvres, Attitudes and Flight Conditions

### Description

#### 1 Approved Maneuvres

##### CAUTION

AEROBATICS, SPINNING, AND FLIGHT MANEUVERS WITH MORE THAN 60° OF BANK ARE NOT PERMITTED IN THE NORMAL CATEGORY.

##### CAUTION

INTENTIONAL NEGATIVE G-MANEUVERS ARE NOT PERMITTED.

The airplane is certified in the Normal Category in accordance with CS-23.

##### Approved Maneuvres

- All normal flight maneuvers;
- Stalling (with the exception of dynamic stalling); and
- Lazy Eights, Chandelles, as well as steep turns and similar maneuvers, in which an angle of bank of not more than 60° is attained.

## 02-09 Maneuvring Load Factors

### Description

#### 1 Maneuvring Load Factors

##### WARNING

THE TABLE BELOW SHOWS STRUCTURAL LIMITATIONS. EXCEEDING THE MAXIMUM LOAD FACTORS WILL LEAD TO AN OVERSTRESSING OF THE AIRPLANE.

##### CAUTION

INTENTIONAL NEGATIVE G-MANEUVERS ARE NOT PERMITTED.

	at $v_o$	at $v_{NE}$	with flaps in T/O or LDG position
Positive	3.8	3.8	2.0
Negative	-1.52	0	0

Table 1 - Maneuvring Load Factors

## 02-10 Operating Altitude

### Description

#### 1 Operating Altitude

The maximum operating altitude is 20,000 ft (6,096 m) pressure altitude.

#### **NOTE**

Additional altitude restrictions based on operational requirements for supplemental oxygen may apply.



## 02-11 Flight Crew Description

### 1 Flight Crew

Minimum crew: 1 (one person)  
Maximum number of  
occupants: 5 (five persons)

## 02-12 Kinds of Operation

### Description

#### 1 Kinds of Operation

Provided that national operational requirements are met, the following kinds of operation are approved:

- Daytime flights according to Visual Flight Rules (VFR)
- With the appropriate equipment: night flights according to Visual Flight Rules (NVFR)
- With the appropriate equipment: flights according to Instrument Flight Rules (IFR)
- Take-off and landing on paved surfaces
- Take-off and landing on unpaved surfaces

Flights into known or forecasted icing conditions are prohibited.

Flights into known or forecasted thunderstorms are prohibited.

#### 1 Minimum Operational Equipment (Serviceable)

The following table lists the minimum serviceable equipment required by CS-23. Additional minimum equipment for the intended operation may be required by national operating rules and also depends on the route to be flown.

#### NOTE

Many of the items of minimum equipment listed in the following table are integrated in the G1000 NXi.

	For daytime VFR flights	In addition for night VFR flights	In addition for IFR flights
Flight and navigation instruments	Airspeed indicator Altimeter Magnetic compass 1 headset, used by pilot in command	Vertical speed indicator (VSI) Artificial horizon (2x) Turn & bank indicator Directional gyro VHF radio (COM) VOR receiver Transponder (XPDR) GPS receiver Second headset	Second airspeed indicator (on PFD and backup) Second altimeter Second attitude gyro (on PFD and backup) Second VHF radio (COM) VOR-LOC-GP receiver Second GPS receiver
Engine instruments	Fuel quantity Oil pressure Oil temperature Coolant temperature Coolant level caution Gearbox temperature	Ammeter Voltmeter	

Table 1 - Minimum Equipment

	For daytime VFR flights	In addition for night VFR flights	In addition for IFR flights
	Load Propeller RPM Fuel temperature left & right tank Fuel flow Fuel pressure ECU A/B caution		
Electrical System	Alternator (1x)	Alternators (2x)	
Lighting		Position lights Strobe lights (anti collision lights) Landing light Instrument lighting Flood light Flashlight	
Other operational minimum equipment	Stall warning system Safety belts for each occupied seat Airplane Flight Manual Egress Hammer Fire Extinguisher Garmin Cockpit Reference Guide	Pitot heating system Alternate static valve	

Table 1 - Minimum Equipment

## 02-13 Limitation Placards

### Description

#### 1 Limitation Placards

All limitation placards relevant for the DA 50 C airplane are shown below. A list of all placards is included in the Airplane Maintenance Manual, latest revision, Chapter 11.

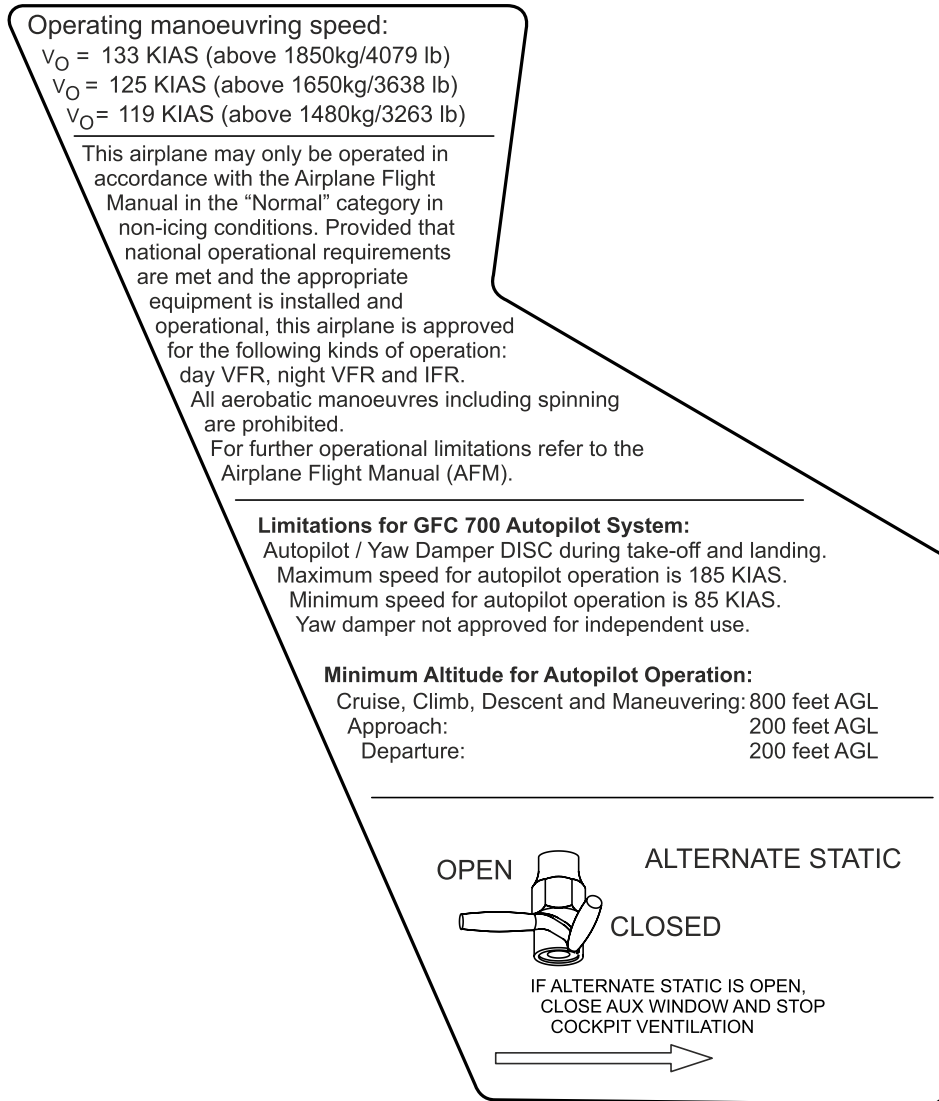

Figure 2 - Limitation Placards 1

On the Instrument Panel:

LANDING GEAR  
 $V_{LE} / V_{LO} = 162$  KIAS

On the Emergency Landing Gear Extension Lever:

EMERGENCY  
Gear Extension  
Max. 102 KIAS

On the Instrument Panel:

max. usable fuel:  
LH (Main) Tank: 25.0 US gal  
RH (Aux) Tank: 24.0 US gal  
max. difference LH/RH  
tank: 9 US gal

Figure 3 - Limitation Placards 2

Next to Each of the Two Filler Necks:



On the Engine Cowling:

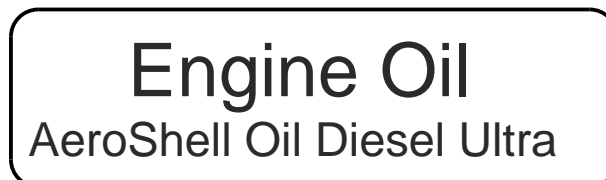
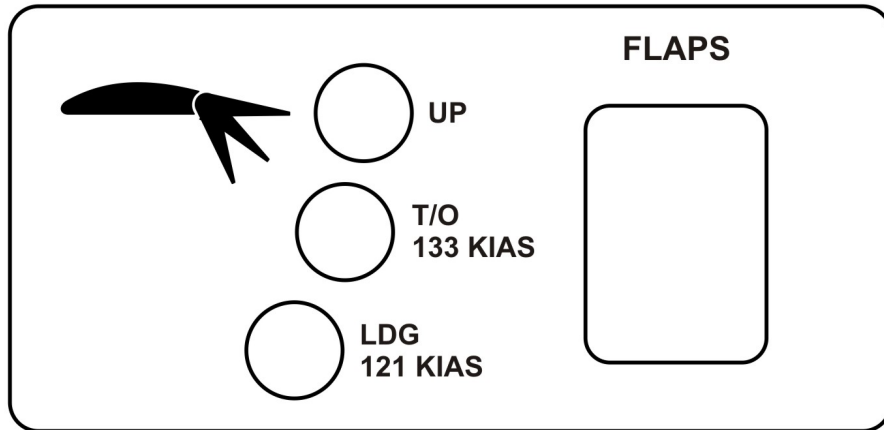

Figure 4 - Limitation Placards 3

Next to the Flap Selector Switch:



Beside the Door Locking Device Installed in the Passengers Door:



On the Bottom Center of the Instrument Panel:



Figure 5 - Limitation Placards 4

On the rear wall:

**BAGGAGE COMPARTMENT**

TOTAL MAX. 75 kg [165 lb]  
 MAX. SINGLE HARDPOINT PRETENSION 8kg [18 lb]  
 BAGGAGE MASS ABOVE FRONT BARRIER MUST NOT EXCEED 50 kg [110 lb]

ALL ITEMS MUST BE PLACED IN FRONT OF EACH BAGGAGE AREA "A" OR "B" AND SECURED AGAINST MOTION

**CAUTION:**  
 OBSERVE WEIGHT & BALANCE LIMITATIONS, SEE AIRPLANE FLIGHT MANUAL CHAPTER 06

**AREA - B**  
 MAX. 35 kg [77lb]  
 ARM: 4.35 m [171.3"]  
 MAX. SURFACE LOAD:  
 123kg/sq. m [25.2 lb/sq. ft]

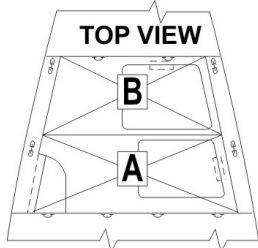

**TOP VIEW**

**AREA - A**  
 MAX. 40 kg [88lb]  
 ARM: 3.98 m [156.7"]  
 MAX. SURFACE LOAD:  
 153kg/sq. m [31.3 lb/sq. ft]

On the inside of the cover and on the inner rear wall of the compartment:

**C-COMP.:**  
 MAX. 10kg [22lb]  
 ARM: 3.98M [156.7"]  
 MAX. SURFACE LOAD:  
 149kg/sq.m [30.5lb/sq.ft]

On the inside of the cover:

**D-COMP.:**  
 MAX. 5kg [11lb]  
 ARM: 4.35m [171.3"]  
 MAX. SURFACE LOAD:  
 60kg/sq.m [12.3lb/sq.ft]

Figure 6 - Limitation Placards 5



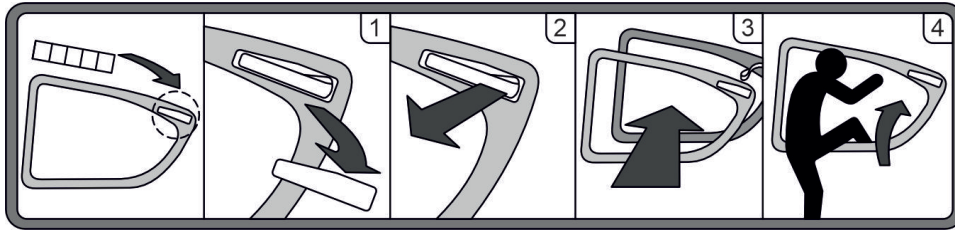

Figure 7 - Limitation Placards 6

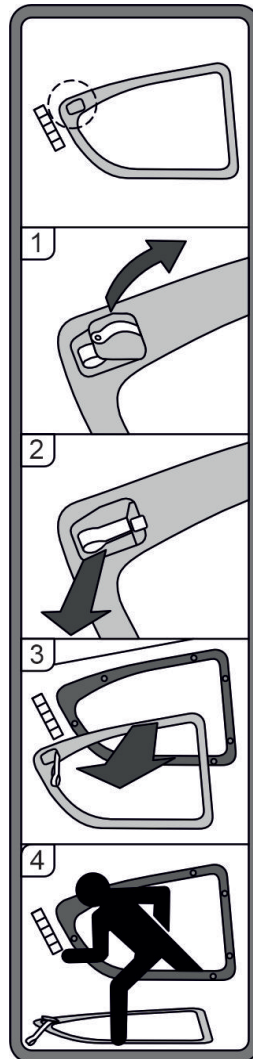

Figure 8 - Limitation Placards 5

TABLET MOUNT:

- SIZE MAX.: 255mm x 200mm  
(10.03" x 7.87")
- WEIGHT MAX.: 1.1kg (2.43lb)
- INTERCONNECTING ARM  
LENGTH MAX.: 76.2mm (3")

Figure 9 - Limitation Placards 8 (if Tablet Mount is installed)

## 02-14 Fuel

### Description

#### 1 Fuel

Approved fuel designations: JET A-1 (ASTM D 1655)  
 JET A (ASTM D 1655)  
 No.3 Jet Fuel (China, GB 6537-2018)

#### NOTE

Use only uncontaminated fuel from reliable sources.

	Main tank (LH)		Aux tank (RH)		Total	
	US gal	Liter	US gal	Liter	US gal	Liter
Total fuel quantity	26.0	98.4	25.5	96.5	51.5	195.0
Unusable fuel	1.0	3.8	1.5	5.7	2.5	9.5
Useable fuel	25.0	94.6	24.0	90.8	49.0	185.5
Max. permissible difference LH/ RH					9.0	35.0

Table 1 - Fuel Tanks

#### 1 Additives

#### CAUTION

IN CASE OF AN UNKNOWN OR AN OVER DOSAGE OF THE FUEL ADDITIVES THE FUEL SYSTEM MUST BE PURGED UNTIL THE DOSAGE IS WITHIN THE PERMITTED LIMITS.

#### NOTE

The specified additives are qualified for the operation with the certified fuel designations.

To clean the fuel system of the airplane a higher dosage of the specified additive is allowed under consideration of the instructions of the additive supplier. During cleaning the engine must not be operated.

Any mixture of the different types of fuel additives is not permitted.

##### 1.1 Operation with Anti-Microbial Life Fuel Additives

The application of the following additives is permitted:

BIOBOR JF MIL-	max. 270 ppm for initial treatment
S-53021A	max. 135 ppm for permanent use after initial treatment

**NOTE**

The instructions of the fuel additive supplier must be followed.

**1.2 Operation with Anti-Icing Fuel Additives**

The application of the following additive is permitted:

PRIST Hi-Flash MIL- max. 1500 ppm  
DTL-85470(B) ASTM D  
4171

**NOTE**

The instructions of the fuel additive supplier must be followed.

## 02-15 Temperature Limitations

### Description

#### 1 Temperature Limits

The airplane may only be operated when its temperature prior to operation is not less than -25 °C (-13 °F).

With the airplane cold soaked and its temperature below -20 °C (-4 °F) the use of an external pre-heater for the engine and pilot compartment prior to operation is mandatory.

## 02-16 Battery Charge

### Description

#### 1 Battery Charge

Take-off for a Night VFR or IFR flight with an empty main battery is not permitted.

The use of an external power supply for engine starting with an empty airplane main battery is not permitted if the subsequent flight is intended to be a Night VFR or an IFR flight. In this case the airplane main battery must be charged first.

## 02-17 Door Locking Device

### Description

#### 1 Door Locking Device

The LH and RH crew doors and the passenger door must not be blocked by the key lock during operation of the airplane.

## 02-18 Electronic Equipment Description

### 1 Portable Electronic Devices

The use of Portable Electronic Devices (PED) during low visibility approaches is prohibited.

#### **NOTE**

Refer to EASA AMC 20-25 or FAA AC 120.76A for the use of PED associated to electronic flight bag (EFB) operation

The use of any device as an EFB may require separate approvals.



## 02-19 Smoking Description

### 1 Smoking

Smoking in the airplane is not permitted.

## 02-20 Garmin G1000 NXi Avionics System

### Description

#### 1 Garmin G1000 Avionics System

- A. The Garmin G1000 NXi Cockpit Reference Guide, P/N 190-02800-( ), appropriate revision must be immediately available to the flight crew.
- B. The Garmin G1000 NXi must utilize the software Garmin 190-02576-( ), approved software in accordance with the mandatory service bulletin DAI MSB 50-003, latest version. [Table 1](#)

#### NOTE

The database version is displayed on the MFD power-up page immediately after system power-up and must be acknowledged. The remaining system software versions can be verified on the AUX group sub-page 5, "AUX-SYSTEM STATUS".

- C. IFR enroute, oceanic and terminal navigation predicated upon the G1000 NXi GPS Receiver is prohibited unless the pilot verifies the currency of the database or verifies each selected way point for accuracy by reference to current approved data.
- D. Instrument approach navigation predicated upon the G1000 NXi GPS Receiver must be accomplished in accordance with approved instrument approach procedures that are retrieved from the GPS equipment database. The GPS equipment database must incorporate the current update cycle.
  - (1) Instrument approach navigation predicated upon the G1000 NXi GPS Receiver must be accomplished in accordance with approved instrument approach procedures that are retrieved from the GPS equipment database. The GPS equipment database must incorporate the current update cycle.
  - (2) Accomplishment of ILS, LOC, LOC-BC, LDA, SDF, MLS or any other type of approach not approved for GPS overlay with the G1000 NXi GPS receiver is not authorized.
  - (3) Use of the G1000 NXi VOR/ILS receiver to fly approaches not approved for GPS require VOR/ILS navigation data to be present on the display.
  - (4) When an alternate airport is required by the applicable operating rules, it must be served by an approach based on other than GPS navigation, the airplane must have the operational equipment capable of using that navigation aid, and the required navigation aid must be operational.
  - (5) VNAV information may be utilized for advisory information only. Use of VNAV information for Instrument Approach Procedures does not guarantee step-down fix altitude protection, or arrival at approach minimums in normal position to land.
  - (6) RNAV (GPS) approaches must be conducted utilizing the GPS sensor.
  - (7) RNP RNAV operations are not authorized, except as noted in Chapter 1 of this AFM.

#### NOTE

Not all published approaches are in the FMS database. The pilot must ensure that the planned approach is in the database.

- E. If not previously defined, the following default settings must be made in the "SYSTEM SETUP" menu of the G1000 NXi prior to operation (refer to Pilot's Guide for procedure if necessary):
  - (1) DIS, SPD : nm, kt (sets navigation units to "nautical miles" and "knots")

- (2) ALT, VS : ft, fpm (sets altitude units to "feet" and "feet per minute")
- (3) POSITION : deg-min (sets navigation grid units to decimal minutes)

### NOTE

Navigation Information is referenced to WGS-84 reference system, and should only be used where the Aeronautical Information Publication (including electronic data and aeronautical charts) conforms to WGS-84 or equivalent.

- F. When AHRS is required to meet the items listed in the minimum operational equipment (serviceable) table in [02-12 - Kinds of Operation - Description](#), operation is prohibited in the following areas:
- North of 72° N latitude at all longitudes.
  - South of 70° S latitude at all longitudes.
  - North of 65° N latitude between longitude 75° W and 120° W (Northern Canada).
  - North of 70° N latitude between longitude 70° W and 128° W (Northern Canada).
  - North of 70° N latitude between longitude 85° E and 114° E (Northern Russia).
  - South of 55° S latitude between longitude 120° E and 165° E (Region south of Australia and New Zealand).

When day VFR operations are conducted in the above areas, the MFD must be in a non-heading up orientation.

- G. The fuel quantity, fuel required, and fuel remaining functions of the FMS are supplemental information only and must be verified by the flight crew.
- H. The GPS is approved for SBAS operations. Refer to [01-07 - G1000 NXi Avionics System - Description](#) for SBAS and P-RNAV Operation.
- I. The availability of SafeTaxi®, ChartView, or FliteCharts® in electronic form on the G1000 NXi is for information purposes only, it is still mandatory to carry another source of charts on-board the airplane.

Software Part Number	Approved Version	Function
System	for approved version see DAI MSB 50-003 latest version	
010-02576-( )		
Manifest		
006-B0093-( )		GPS1, GPS2
006-B0172-( )		GTX1-GIA1, GTX1-GIA2
006-B0190-( )		GIA1, GIA2
006-B0193-( )		GEA1-GIA1; GEA1-GIA2
006-B0203-( )		GMA1-GIA1, GMA1-GIA2
006-B0223-( )		GRS1-GIA1, GRS1-GIA2
006-B0224-( )		GMU1
006-B0319-( )		PFD1, MFD1
006-B0328-( )		
006-B0329-( )		
006-C0048-( )		GMU1 FPGA
006-C0049-( )		GRS1 FPGA
006-C0055-( )		GDC1 FPGA
006-D0159-( )		GRS1 MV DB
006-D0202-( )		
006-B0261-( )		GDC1-GIA1
006-B0081-( )		COM1, COM2
006-B0083-( )		GS1, GS2
006-B0082-( )		NAV1, NAV2

Table 1 - Garmin Software Versions

## 02-21 Garmin G1000 NXi GPS Navigation System Limitations

### Description

#### 1 G1000 NXi GPS Navigation System Limitations

##### 1 Flight Preparation Phase

For flight planning purposes, operations on RNP and RNAV procedures when SBAS signals are not available, the availability of GPS integrity RAIM shall be confirmed for the intended route of flight. In the event of a predicted continuous loss of RAIM of more than five minutes for any part of the intended route of flight, the flight should be delayed, cancelled, or re-routed on a track where RAIM requirements can be met.

For flight planning purposes for operations within European B-RNAV and P-RNAV airspace, if more than one satellite is scheduled to be out of service, then the availability of GPS integrity RAIM shall be confirmed for the intended flight (route and time). In the event of a predicted continuous loss of RAIM of more than five minutes for any part of the intended flight, the flight should be delayed, cancelled, or re-routed on a track where RAIM requirements can be met.

For flight planning purposes, operations where the route requires Class II navigation the airplane's operator or pilot-in-command must use the Garmin WFDE Prediction program to demonstrate that there are no outages on the specified route that would prevent the Garmin GNSS navigation system to provide primary means of Class II navigation in oceanic and remote areas of operation that requires (RNP-10 or RNP-4) capability. If the Garmin WFDE Prediction program indicates fault exclusion (FDE) unavailability will exceed 34 minutes in accordance with FAA Order 8400.12A for RNP-10 requirements, or 25 minutes in accordance with FAA Order 8400.33 for RNP-4 requirements, then the operation must be rescheduled when FDE is available.

#### NOTE

Within the United States, RAIM availability can be determined using the Garmin WFDE Prediction program 3.00 or later approved version with Garmin GA36 or Comant CI 2580-200 antenna selected, or the FAA's en route and terminal RAIM prediction website: <http://sapt.faa.gov>, or by contacting a Flight Service Station.

#### NOTE

Within Europe, RAIM availability can be determined using the Garmin WFDE Prediction program or Europe's AUGER GPS RAIM Prediction Tool at: <http://augur.ecacnav.com/augur/app/home>. For other areas, use the Garmin WFDE Prediction program. This requirement is not necessary if SBAS coverage is confirmed to be available along the entire route of flight. The route planning and WFDE prediction program may be downloaded from the GARMIN website on the internet. For information on using the WFDE Prediction Program, refer to GARMIN WAAS FDE Prediction Program, part number 190-00643-01, 'WFDE Prediction Program Instructions'.

Navigation information is referenced to WGS-84 reference system, and should only be used where the Aeronautical Information Publication (including electronic data and aeronautical charts) conform to WGS-84 or equivalent.

## 2 Preflight Phase

SBAS functionality must be enabled on the G1000 NXi GPS Status page (refer to the G1000 NXi Pilot's Guide for procedure).

The pilot must confirm at system initialization that the Navigation database is current. GPS/SBAS based IFR enroute, oceanic, and terminal navigation is prohibited unless the pilot verifies and uses a valid, compatible, and current Navigation database or verifies each waypoint for accuracy by reference to current approved data.

Navigation database is expected to be current for the duration of the flight. If the AIRAC cycle will change during flight, the pilot must ensure the accuracy of navigation data, including suitability of navigation facilities used to define the routes and procedures for flight. If an amended chart affecting navigation data is published for the procedure, the database must not be used to conduct the procedure.

### NOTE

Discrepancies that invalidate a procedure must be reported to Garmin International. The affected procedure is prohibited from being flown using data from the Navigation database until a new Navigation database is installed in the airplane and verified that the discrepancy has been corrected. Contact information to report Navigation database discrepancies can be found at [www.Garmin.com](http://www.Garmin.com)>Support>Contact Garmin Support>Aviation. Pilots and operators can view navigation data base alerts at [www.Garmin.com](http://www.Garmin.com) > In the Air> NavData Alerts.

Both Garmin GPS navigation receivers must be operating and providing GPS navigation guidance to their PFD for operations requiring RNP-4 performance.

North Atlantic (NAT) Minimum Navigational Performance Specifications (MNPS) Airspace operations per FAA AC 91-49 and FAA AC 120-33 require both GPS/SBAS receivers to be operating and receiving usable signals except for routes requiring only one Long Range Navigation sensor.

## 3 In Flight Phase

Manual entry of waypoints using latitude/longitude or place/bearing is prohibited.

### NOTE

Whenever possible, RNP and RNAV routes including Standard Instrument Departures (SIDs) and Obstacle Departure Procedures (ODPs), Standard Terminal Arrival (STAR), and enroute RNAV "Q" and RNAV "T" routes should be loaded into the flight plan from the database in their entirety, rather than loading route waypoints from the database into the flight plan individually. Selecting and inserting individual named fixes from the database is permitted, provided all fixes along the published route to be flown are inserted.

## 4 Approach Phase

GPS based instrument approaches must be flown in accordance with an approved instrument approach procedure that is loaded from the Navigation database.

**NOTE**

Not all published Instrument Approach Procedures (IAP) are in the Navigation database. Pilots planning on flying an RNAV instrument approach must ensure that the Navigation database contains the planned RNAV Instrument Approach Procedure and that approach procedure must be loaded from the Navigation database into the FMS flight plan by its name.

IFR non-precision approach approval using the GPS/SBAS sensor is limited to published approaches authorized by the appropriate governing authority.

The navigation equipment required to join and fly an instrument approach procedure is indicated by the title of the procedure and notes on the IAP chart. Use of the Garmin GPS/SBAS receivers to provide navigation guidance during the final approach segment of an ILS, LOC, LOC-BC, LDA, SDF, MLS or any other type of approach not approved for "or GPS" navigation is prohibited. When using the Garmin VOR/LOC/GS receivers to fly the final approach segment, VOR/LOC/GS navigation data must be selected and presented on the CDI of the pilot flying.

## 02-22 Autopilot Limitations

### Description

#### 1 Autopilot Limitations

- A. It is the responsibility of the pilot in command to monitor the autopilot when it is engaged. The pilot should be prepared to immediately disconnect the autopilot and to take prompt corrective action in the event of unexpected or unusual autopilot behavior.
- B. The autopilot and yaw damper must be disconnected (using the AP DISC button) during take-off and landing.
- C. Following an autopilot or electric trim malfunction, reengaging the autopilot or manual electric trim, or resetting the AFCS / ESP circuit breaker is prohibited, until the cause of the malfunction has been determined and corrected.
- D. The Garmin G1000 NXi Cockpit Reference Guide for the Diamond DA 50 C, P/N 190-02800- ( ) approved revision must be immediately available to the flight crew.
- E. ILS approaches using the autopilot / flight director are limited to Category I approaches only.
- F. Autopilot maximum airspeed: 185 KIAS  
Autopilot minimum airspeed: 85 KIAS
- G. Altitude select captures below 1200 feet AGL are prohibited.
- H. The autopilot must be disengaged:
  - below 200 ft AGL during approach,
  - below 200 ft AGL during departure,
  - below 800 ft AGL for all other phases of flight.
- I. Overriding the autopilot to change pitch or roll attitude is prohibited. (Disengage or press CWS while maneuvering.)
- J. The AFCS pre-flight test must be successfully completed prior to use of the autopilot, flight director, yaw damper or manual electric trim.
- K. A pilot with the seat belt fastened must occupy the left pilot's seat during all operations.
- L. The yaw damper is an integral part of the autopilot system and must not be used separately.



# 03 EMERGENCY PROCEDURES

# EMERGENCY PROCEDURES GENERAL

## 03-01 Emergency procedures

### Description

#### 1 Introduction

##### **WARNING**

**IN EACH EMERGENCY, CONTROL OVER THE FLIGHT ATTITUDE AND THE PREPARATION OF A POSSIBLE EMERGENCY LANDING HAVE PRIORITY OVER ATTEMPTS TO SOLVE THE CURRENT PROBLEM ("FIRST FLY THE AIRCRAFT"). PRIOR TO THE FLIGHT THE PILOT MUST CONSIDER THE SUITABILITY OF THE TERRAIN FOR AN EMERGENCY LANDING FOR EACH PHASE OF THE FLIGHT. FOR A SAFE FLIGHT THE PILOT MUST CONSTANTLY KEEP A SAFE MINIMUM FLIGHT ALTITUDE. SOLUTIONS FOR VARIOUS ADVERSE SCENARIOS SHOULD BE THOUGHT OVER IN ADVANCE. THIS SHOULD PREVENT A SITUATION WHERE THE PILOT IS FACED WITH AN EMERGENCY HE CANNOT HANDLE CALMLY AND WITH DETERMINATION.**

This Chapter contains checklists as well as the description of recommended procedures to be followed in the event of an emergency. Engine failure or other airplane-related emergencies are most unlikely to occur if the prescribed procedures for pre-flight checks and airplane maintenance are followed.

If, nonetheless, an emergency does arise, the guidelines given here should be followed and applied in order to clear the problem.

As it is impossible to foresee all kinds of emergencies and cover them in this Airplane Flight Manual, a thorough understanding of the airplane by the pilot is, in addition to his knowledge and experience, an essential factor in the solution of any problems which may arise.

## 03-02 Certain Airspeeds in Emergencies

### Description

#### 1 Certain Airspeeds in Emergencies

Event		KIAS
Airspeed for best glide angle (Flaps UP)		94
Airspeed for emergency landing with engine off	Flaps UP	94
	Flaps T/O	85
	Flaps LDG	77
Emergency gear extension		≤ 102
Airspeed for Engine Restart (windmilling)		122

**Table 1 - Certain Airspeeds in Emergencies**

## 03-03 Selecting Emergency Frequency

### Emergency operation procedure

#### 1 Selecting Emergency Frequency

In an in-flight emergency, depressing and holding the Com transfer button ↔ on the G1000 for 2 seconds will tune the emergency frequency of 121.500 MHz. If the display is available, it will also show it in the "Active" frequency window.

# AIRPLANE RELATED CAS WARNINGS

## 03-04 Airplane related G1000 Warning Messages

### Emergency operation procedure

#### 1 Crew Alert System (CAS) Warning Messages

CAS Message	Cause	Corrective Action
<b>ALTN 1 AMPS</b>	Engine alternator 1 output is higher than 70 A.	See <a href="#">03-05 - ALTN 1/2 AMPS - Emergency operation procedure.</a>
<b>ALTN 2 AMPS</b>	Engine alternator 2 output is higher than 70 A.	See <a href="#">03-05 - ALTN 1/2 AMPS - Emergency operation procedure.</a>
<b>ALTN 1 FAIL</b>  AND <b>ALTN 2 FAIL</b>	Engine alternator 1 AND engine alternator 2 have failed.	See <a href="#">03-06 - ALTN 1/2 FAIL - Emergency operation procedure.</a>
<b>COOLANT TEMP</b>	Coolant temperature is above 105 °C.	See <a href="#">03-07 - COOLANT TEMP - Emergency operation procedure.</a>
<b>ENG INTAKE</b>	Engine air intake temperature is above 80 °C.	See <a href="#">03-15 - ENG INTAKE - Emergency operation procedure.</a>
<b>ENG OIL TEMP</b>	Engine oil temperature is above 125 °C.	See <a href="#">03-08 - ENG OIL TEMP - Emergency operation procedure.</a>
<b>FUEL PRESS</b>	Engine fuel pressure is above 1.0 bar or below -0.3 bar.	See <a href="#">03-09 - FUEL PRESS - Emergency operation procedure.</a>
<b>GB OIL TEMP</b>	Gearbox oil temperature is above 110 °C.	See <a href="#">03-10 - GB OIL TEMP - Emergency operation procedure.</a>
<b>L DOOR OPEN</b>	Front left door is not closed and locked.	See <a href="#">03-11 - Unlocked Doors - Emergency operation procedure.</a>
<b>L FUEL TEMP</b>	Fuel temperature in left fuel tank is above 60 °C.	See <a href="#">03-12 - L/R FUEL TEMP - Emergency operation procedure.</a>
<b>OIL PRES</b>	Engine oil pressure is above 7.5 bar or below 2.0 bar.	See <a href="#">03-13 - OIL PRES - Emergency operation procedure.</a>

CAS Message	Cause	Corrective Action
<b>R DOOR OPEN</b>	Front right door is not closed and locked.	See <a href="#">03-11 - Unlocked Doors - Emergency operation procedure.</a>
<b>R FUEL TEMP</b>	Fuel temperature in right fuel tank is above 60 °C.	See <a href="#">03-12 - L/R FUEL TEMP - Emergency operation procedure.</a>
<b>REAR DOOR OPEN</b>	Rear door is not closed and locked.	See <a href="#">03-11 - Unlocked Doors - Emergency operation procedure.</a>
<b>STARTER</b>	Engine starter is engaged.	See <a href="#">03-14 - Starter Malfunction - Emergency operation procedure.</a>



## 03-05 ALTN 1/2 AMPS

### Emergency operation procedure

#### 1 Alternator High Load / High Current

**ALTN 1 AMPS**

**ALTN 2 AMPS**

Engine alternator output is in the upper red range (too high / above 70 A).

This warning is indicated when the consumption of electrical power is too high.

Possible reasons are a fault in wiring or equipment.

- A ENGINE SYSTEM DISPLAY.....select by pressing ENGINE softkey on MFD
- B Electrical equipment.....switch OFF as necessary and possible  
to reduce electric load
- C Circuit breakers.....check
- D Ammeter/Voltmeter.....monitor
- E Land on the nearest suitable airfield.

**03-06 ALTN 1/2 FAIL**  
**Emergency operation procedure**

**1 Alternator 1 and Alternator 2 Failure**

**ALTN 1 FAIL**

AND

**ALTN 2 FAIL**

Both engine alternators have failed.

**WARNING**

**THE ECU, WHICH IS ABSOLUTELY NECESSARY FOR ENGINE OPERATION, NEEDS ELECTRICAL POWER. IF BOTH ALTERNATORS FAIL AT THE SAME TIME, REDUCE ALL ELECTRICAL EQUIPMENT TO A MINIMUM. EXPECT BATTERY POWER TO LAST 30 MINUTES AND LAND THE AIRPLANE AS SOON AS POSSIBLE. EXPECT ENGINE STOPPAGE AFTER THIS PERIOD OF TIME. BE PREPARED FOR AN ENGINE FAILURE AND AN EMERGENCY LANDING.**

A Circuit breakers.....all in

***If there is still no electrical power available:***

- B Landing Gear.....DOWN,  
when down and locked pull Emergency Release
- C ESSENTIAL BUS.....ON
- D Alternator 1/2 switches.....OFF
- E PITOT/STALL HEAT.....OFF
- F All lights.....OFF
- G Electrical equipment.....switch OFF all equipment which is not needed
- H Land on the nearest suitable airfield.

Prepare for an engine failure in accordance with [03-18 - Engine Failure in Flight - Emergency operation procedure](#).

## 03-07 COOLANT TEMP

### Emergency operation procedure

#### 1 Coolant Temperature High

COOLANT TEMP

Engine coolant temperature is in the upper red range (too high / above 105 °C).

Coolant temperatures above the limit value of 105 °C can lead to a total loss of power due to engine failure.

A COOLANT LVL caution message.....check

***If COOLANT LVL is displayed***

B POWER.....reduce

C COWL FLAP.....open

D Expect loss of coolant.

E A further increase in coolant temperature must be expected.

Prepare for an engine failure in accordance with [03-18 - Engine Failure in Flight - Emergency operation procedure](#).

#### NOTE

If high coolant temperature is indicated and the COOLANT LVL caution message is not displayed, it can be assumed that there is no technical defect in the cooling system and that the below mentioned procedure can decrease the temperature(s).

***If COOLANT LVL is NOT displayed***

***During climb***

F POWER.....reduce by 10% or more as required

G COWL FLAP.....open

H Airspeed.....increase by 10 KIAS or more as required

I COOLANT TEMP.....check for green range

If the coolant temperature does not reach the green range within 60 seconds, reduce power as far as possible and increase airspeed.

J If the coolant temperature does not return to the green range perform a precautionary landing on the nearest suitable airfield.

Prepare for an engine failure in accordance with [03-18 - Engine Failure in Flight - Emergency operation procedure](#).

***During cruise***

- K POWER.....reduce  
or
- L Airspeed.....increase, if necessary by initiating a descent
- M COWL FLAP.....open
- N COOLANT TEMP.....check for green range
- O If the coolant temperature does not return to the green range, perform a precautionary landing on the nearest suitable airfield.  
Prepare for an engine failure in accordance with [03-18 - Engine Failure in Flight - Emergency operation procedure](#).

**03-08 ENG OIL TEMP**  
**Emergency operation procedure**

**1 Engine Oil Temperature High**

**ENG OIL TEMP**

Engine oil temperature is in the upper red range (too high / above 125 °C).

Oil temperatures above the limit value of 125 °C can lead to a total loss of power due to engine failure.

A OIL PRES .....check

***If OIL PRES Is Outside of Green Range (Lower Limit)***

B POWER.....reduce

C COWL FLAP.....open

D Expect loss of engine oil.

A further increase in oil temperature must be expected.

Prepare for an engine failure in accordance with [03-18 - Engine Failure in Flight - Emergency operation procedure](#).

**NOTE**

If high oil temperature is announced and the oil pressure indication is within the green range, it can be assumed that there is no technical defect in the engine oil system and that the below mentioned procedure can decrease the temperature(s).

***If OIL PRES Is Within Green Range***

E POWER.....reduce

F COWL FLAP.....open

G Airspeed.....increase

H ENG OIL TEMP.....check for green range

I If the oil temperature does not return to the green range, perform a precautionary landing on the nearest suitable airfield.

Prepare for an engine failure in accordance with [03-18 - Engine Failure in Flight - Emergency operation procedure](#).

**03-09 FUEL PRESS**  
**Emergency operation procedure**

**1 Fuel Pressure**

**FUEL PRESS**

Engine fuel pressure is below -0.3 bar or above 1.0 bar.

***Fuel Pressure Low***

- A Fuel quantity.....check
- B FUEL valve.....check NORMAL
- C EMERGENCY FUEL PUMP switch.....ON

***If FUEL PRESS warning remains***

- D FUEL valve.....EMERGENCY
- E EMERGENCY FUEL PUMP switch.....OFF

***If FUEL PRESS warning still remains***

- F Imminent engine failure must be expected.

Prepare for an engine failure in accordance with [03-18 - Engine Failure in Flight - Emergency operation procedure](#).

## 03-10 GB OIL TEMP

### Emergency operation procedure

#### 1 Gearbox Oil Temperature High

GB OIL TEMP

Engine gearbox temperature is in the upper red range (too high / above 110 °C).

Gearbox temperatures above the limit value of 110 °C can lead to a total loss of power due to engine failure.

At high ambient temperature conditions and/or at low airspeeds with high power settings, it can be assumed that there is no technical defect in the gearbox and that the below mentioned procedure will decrease the temperature(s).

- A POWER.....reduce
- B COWL FLAP.....open
- C Airspeed.....increase
- D GB OIL TEMP.....check for green range
- E If the gearbox oil temperature does not return to the green range, perform a precautionary landing on the nearest suitable airfield.

Prepare for an engine failure in accordance with [03-18 - Engine Failure in Flight - Emergency operation procedure](#).

# 03-11 Unlocked Doors

## Emergency operation procedure

### 1 Unlocked Doors

**L DOOR OPEN**

**R DOOR OPEN**

**REAR DOOR OPEN**

Left, Right or Rear Door is not closed.

- A    Airspeed.....reduce immediately
- B    Doors.....check visually if closed
- C    Rear door.....check visually if closed

#### ***Doors Unlocked***

- D    Airspeed.....below 140 KIAS
- E    Land at next suitable airfield.

#### ***Rear Door Unlocked***

### **WARNING**

**DO NOT TRY TO LOCK THE REAR DOOR IN FLIGHT. THE SAFETY LATCH MAY DISENGAGE AND THE DOOR OPENS. USUALLY THIS RESULTS IN A SEPARATION OF THE DOOR FROM THE AIRPLANE.**

### **NOTE**

If the rear door has been lost, the airplane can be safely flown to the next suitable airfield.

- F    Airspeed.....below 140 KIAS
- G    Land at next suitable airfield.



**03-12 L/R FUEL TEMP**  
**Emergency operation procedure**

**1 Fuel Temperature High**

**L FUEL TEMP**

**R FUEL TEMP**

Fuel temperature is in the upper red range (too high / above 61 °C).

Fuel temperatures above the limit value of 61 °C can lead to a noticeable reduction of the high pressure pump efficiency.

At high ambient temperature conditions and/or at low airspeeds with high power settings and low fuel quantities, it can be assumed that the following procedure will decrease the temperature(s).

- A POWER.....reduce
- B COWL FLAP.....open
- C Airspeed.....increase
- D L FUEL TEMP / R FUEL TEMP.....check for green range
- E If the fuel temperature does not return to the green range perform a precautionary landing on the nearest suitable airfield.

**NOTE**

Increased fuel temperature can occur when the fuel quantity in the main tank is low. The fuel temperature can be decreased by transferring fuel from the auxiliary to the main tank.

## 03-13 OIL PRES

### Emergency operation procedure

#### 1 Oil Pressure

**OIL PRES**

Engine oil pressure is in the lower red range (too low / below 2.0 bar) or higher red range (too high / above 7.5 bar).

Oil pressures below the limit value of 2.0 bar can lead to a total loss of power due to engine failure.

#### On Ground

**WARNING**

**IF THE PROBLEM CANNOT BE CLEARED, THE AIRPLANE MUST NOT BE FLOWN.**

**CAUTION**

**IF THE OIL PRESSURE IS IN THE RED RANGE, THE ENGINE MUST BE SHUT DOWN IMMEDIATELY.**

- A POWER lever.....Ground Idle (GI)
- B Brakes.....as required
- C ENGINE MASTER.....OFF

#### During flight

#### Oil Pressure Low

**NOTE**

If the RPM indication is less than 1500 RPM with the power lever at Flight Idle (FI), the oil pressure must drop into the red range to cause the caution light to illuminate.

- D POWER.....reduce
- E Oil temperature.....monitor
- F Expect loss of oil with engine failure. Prepare for an emergency landing without engine power in accordance with [03-41 - Emergency Landing with Engine Off - Emergency operation procedure](#).

#### Oil Pressure High

**CAUTION**

**WHEN STARTING A COLD ENGINE, THE OIL PRESSURE CAN BE AS HIGH AS 6.5 BAR FOR A MAXIMUM OF 20 SECONDS.**

G Oil temperature.....check

H Coolant temperature.....check

***If temperatures are within green range***

I Expect wrong oil pressure indication. Keep monitoring temperatures.

***If temperatures are not within green range***

J POWER.....reduce

K Expect engine failure and prepare for an emergency landing without engine power in accordance with [03-41 - Emergency Landing with Engine Off - Emergency operation procedure](#).

## 03-14 Starter Malfunction

### Emergency operation procedure

#### 1 Starter Malfunction

#### STARTER

If the starter does not disengage from the engine after starting (Starter engaged warning STARTER illuminates after the engine has started).

#### ***On Ground***

- A POWER lever.....Ground Idle (GI)
- B ENGINE MASTER.....OFF
- C ELECT. MASTER.....OFF
- D Terminate flight preparation!

#### ***In Flight***

- E Land as soon as possible.

**03-15 ENG INTAKE**  
**Emergency operation procedure**

**1 Engine Air Intake Temperature High**

**ENG INTAKE**

Engine air intake temperature is high (above 80 °C) for more than 30 seconds.

High engine intake temperatures leads to reduces power output.

- A POWER.....reduce
- B COWL FLAP.....check open
- C Airspeed.....increase
- D Check if ENG INTAKE Warning reverts to Caution status. Continue with [03A-13 - ENG INTAKE - Special operation](#).

# ENGINE FAILURES

## 03-16 Engine Failure during Take-Off

### Emergency operation procedure

#### 1 Engine Failure during Take-Off

##### ***Take-Off Can Still Be Aborted (Sufficient Runway Length Available)***

- A POWER lever.....Ground Idle (GI)
- B Brakes.....Apply, as needed
- C ENGINE MASTER.....OFF
- D FUEL valve.....OFF (lift and turn)

#### **NOTE**

Inform ATC if needed.

- E ELECT. MASTER.....OFF

#### **NOTE**

On night operation keep the ELECT. MASTER ON for LDG and Taxi lights.

- F Abort take-off and land straight ahead.

##### ***Continued Take-Off***

- G POWER lever.....check MAX
- H EMERGENCY FUEL PUMP switch.....check ON
- I FADEC switch.....FORCE B

#### **NOTE**

If selecting FORCE B does not solve the problem, switch back to AUTO.

- J ALTERNATE AIR.....OPEN
- K If power output is sufficient to continue flight land as soon as possible.

##### ***If power output is too low to continue flight***

- L POWER lever.....Flight Idle (FI)
- M ENGINE MASTER.....OFF
- N FUEL valve.....OFF
- O Airspeed, Landing Gear, Flaps.....as required
- P Land at best location within safe reach (if possible straight ahead, turning only to avoid obstacles).

# 03-17 Engine Failures on Ground Emergency operation procedure

## 1 Engine Failures on Ground

- A POWER lever.....Ground Idle (GI)
- B Brakes.....as required

### WARNING

**IF THE PROBLEM CANNOT BE CLEARED, TAKE-OFF IS PROHIBITED.**

### CAUTION

**IF THE OIL PRESSURE IS IN THE RED RANGE, THE ENGINE MUST BE SHUT DOWN IMMEDIATELY.**

### NOTE

If considered necessary, the engine must be shut down. Otherwise the cause of the problem must be established in order to re-establish engine performance.



## 03-18 Engine Failure in Flight

### Emergency operation procedure

#### 1 Engine Failure in Flight

#### WARNING

**CONTROL OVER THE FLIGHT ATTITUDE HAS PRIORITY OVER ATTEMPTS TO SOLVE THE CURRENT PROBLEM ("FIRST FLY THE AIRPLANE").**

#### NOTE

As long as there is no major mechanical engine defect, the propeller will continue to windmill.

A	Airspeed.....	94 KIAS
B	FLAPS.....	UP
C	COWL FLAP.....	CLOSED
D	ELECT. MASTER.....	check ON
E	Engine parameters.....	check
F	Fuel quantity MAIN tank.....	check
G	FUEL valve.....	check NORMAL
H	EMERGENCY FUEL PUMP switch.....	ON

#### ***If in icing conditions, visible moisture***

I	ALTERNATE AIR.....	ON
---	--------------------	----

#### ***If failure persists***

J	POWER lever.....	MAX
K	FUEL valve.....	EMERGENCY
L	ECU A/B FAIL caution.....	check PFD annunciation window

#### ***If one ECU FAIL caution is present***

M	Engine parameters.....	check
N	PFD.....	monitor for eventual second ECU FAIL caution
O	Continue flight to next suitable airfield	

#### ***If two ECU FAIL cautions are present***

P	Engine parameters.....	check
Q	Continue flight to next suitable airfield	

**If Failure persists**

R FADEC switch.....FORCE B

**NOTE**

If selecting FORCE B does not solve the problem, switch back to AUTO.

**If engine failure does not clear itself immediately, and the engine is no longer producing sufficient power**

S Try to restart the engine, refer to [03-19 - Restart Engine in Flight - Emergency operation procedure](#).

**If the remaining altitude is NOT sufficient for a restart attempt**

T Perform a precautionary landing on the nearest airfield.

U Prepare for an emergency landing without engine power in accordance with [03-41 - Emergency Landing with Engine Off - Emergency operation procedure](#).

## 03-19 Restart Engine in Flight

### Emergency operation procedure

#### 1 Restart Engine in Flight

The propeller probably continues to windmill. A stopped propeller may indicate a major mechanical defect. In this case use starter assisted restart with extreme caution.

Initiate engine restart below 15000 ft.

#### ***If above 15000 ft***

A Initiate descent to 15000 ft

Gear.....DOWN

Airspeed.....122 KIAS

COWL FLAP.....CLOSED

#### ***On reaching 15000 ft***

B Gear.....UP

C COWL FLAP.....check CLOSED

D ELECT. MASTER.....check ON

E Fuel quantity.....check

F FUEL valve.....If MAIN tank is empty, select AUX tank

G EMERGENCY FUEL PUMP switch.....ON

H FADEC switch.....check AUTO

I POWER lever.....Flight Idle (FI)

J Airspeed.....122 KIAS

K ENGINE MASTER.....OFF - ON

L POWER lever..... move forward and check whether engine is producing thrust

#### **NOTE**

If necessary repeat [step I](#) through [step L](#) multiple times in 1.000 ft steps.

#### **NOTE**

In absence of mechanical defects prohibiting a successful restart it was demonstrated that even in a worst case setting (low grade fuel quality and cold environmental conditions) the engine restarts at altitudes below 6.500 ft.

#### ***If engine does not restart***

M Prepare for an emergency landing without engine power in accordance with [03-41 - Emergency Landing with Engine Off - Emergency operation procedure](#).

# 03-20 Defective RPM Regulating System Emergency operation procedure

## 1 Defective RPM Regulating System

### WARNING

IN CASE OF DEFECTIVE RPM REGULATING SYSTEM, REDUCED ENGINE PERFORMANCE SHOULD BE ANTICIPATED.

### CAUTION

FOLLOWING A FAILURE OF THE PROPELLER CONTROL REGULATOR THE RPM SHOULD BE ADJUSTED WITH THE POWER LEVER.

### CAUTION

THE POWER LEVER SHOULD BE MOVED SLOWLY, IN ORDER TO AVOID OVER-SPEEDING AND EXCESSIVELY RAPID RPM CHANGES. THE LIGHT WOODEN PROPELLER BLADES PRODUCE MORE RAPID RPM CHANGES THAN METAL BLADES.

### *Oscillating RPM*

A POWER setting.....change

### *If the Problem Does Not Clear*

B FADEC switch.....FORCE B

### *If the Problem Does Not Clear*

C FADEC switch.....AUTO

D Land on the nearest suitable airfield.

### *Propeller Overspeed*

### CAUTION

CLIMB PERFORMANCE WILL BE REDUCED.

### NOTE

The propeller now works like a fixed pitch propeller. RPM is controlled by the engine power setting. Flight to the nearest airfield can be continued with a lower power setting and at a lower airspeed. Climb and go-around may not be possible under all conditions.

E POWER lever.....reduce to not exceed 2300 RPM

F Airspeed.....94 KIAS

G FLAPS.....check UP

**After RPM has Stabilized Below 2300 RPM**

- H    Airspeed..... as required, do not exceed 2300 RPM
- I    POWER lever..... as required, do not exceed 2300 RPM

**If the Problem Does Not Clear:**

- J    FADEC switch.....FORCE B

**If Selecting FORCE B Does Not Solve the Problem**

- K    FADEC switch.....AUTO
- L    Keep controlling the climb/sink rate with the POWER lever and do not exceed 2300 RPM.

**If the Problem Does Not Clear**

- M    Land on the nearest suitable airfield.

**If an Increased Climb Gradient is Required**

- N    FLAPS.....T/O position
- O    Airspeed.....79 KIAS
- P    POWER lever.....as required, do not exceed 2300 RPM

**Propeller Underspeed**

- Q    POWER lever.....as required

**If the Problem Does Not Clear**

- R    FADEC switch.....FORCE B

**If the Problem Does Not Clear**

- S    FADEC switch.....AUTO
- T    POWER lever.....as required

**WARNING**

**DUE TO THIS PROBLEM THE PROPELLER RPM WILL DROP.  
THERE MAY BE NO CLIMB PERFORMANCE AND NO GO-  
AROUND POWER AVAILABLE.**

Land on the nearest suitable airfield.

## 03-21 Defective Cowl Flap Emergency operation procedure

### 1 Defective Cowl Flap

Cowl flap indicator light does not indicate the selected cowl flap position.

A Coolant temperature.....check

The flight can be continued, but coolant temperature has to be monitored.

If the coolant temperature becomes high follow the procedure according to [03-07 - COOLANT TEMP - Emergency operation procedure](#).

## 03-22 Inflight Engine Troubleshooting

### Emergency operation procedure

#### 1 Engine Troubleshooting

#### WARNING

**CONTROL OVER THE FLIGHT ATTITUDE HAS PRIORITY OVER ATTEMPTS TO SOLVE THE CURRENT PROBLEM ("FIRST FLY THE AIRCRAFT")**

#### NOTE

As long as there is no major mechanical engine defect, the propeller will continue to windmill.

- A    Airspeed.....94 KIAS
- B    FLAPS.....UP
- C    POWER lever.....check

#### NOTE

If the loss of power was due to unintentional setting of the POWER lever, you may adjust the friction lock and continue your flight.

- D    If in icing conditions.....ALTERNATE AIR OPEN
- E    Fuel quantity.....check

#### NOTE

In case of low fuel quantity in the main fuel tank you may feed it from the auxiliary fuel tank by setting the FUEL valve to EMERGENCY.

- F    FUEL valve.....check ON / EMERGENCY if required

#### NOTE

If the loss of power was due to unintentional setting of the FUEL valve to the OFF position you may continue your flight but have the proper function of the restrainer lock checked prior to next flight.

- G    FADEC.....FORCE B

#### NOTE

If the swap to ECU B has restored engine power land as soon as possible. If selecting FORCE B does not solve the problem, switch back to AUTO in order to maintain the engine control system redundancy.

- H    Circuit breakers.....check / reset if necessary

#### NOTE

If resetting the circuit breakers has restored engine power, land as soon as possible.

If the engine power could not be restored by this procedure, prepare for [03-18 - Engine Failure in Flight - Emergency operation procedure](#) and land as soon as possible.



# LANDING GEAR SYSTEM FAILURES

## 03-23 Emergency Gear Extension

### Emergency operation procedure

## 1 Emergency Gear Extension

### NOTE

In case of a failure of the electrical pump, which is driving the landing gear actuators, the landing gear can be extended manually at speeds up to 102 KIAS. The manual extension of the landing gear may take up to 20 sec.

***The following checks shall be completed before extending the landing gear manually:***

- A ELECT. MASTER.....check ON
- B Gear indicator lights.....push toggle to test switch
- C Bus voltage.....check in normal range
- D Circuit breaker.....check in / reset if required

***Emergency landing gear extension procedure:***

- E Gear selector.....select DOWN
- F Airspeed.....max. 102 KIAS
- G Emergency Gear Extension lever.....pull out

### NOTE

The landing gear should now extend by gravity, spring force and relief of hydraulic pressure from the system. If one or more landing gear indicator lights do not indicate the gear down and locked after completion of the manual extension procedure [step A](#) through [step G](#) reduce airspeed below 102 KIAS and apply moderate yawing and pitching to bring the landing gear into the locked position.

- H Gear indicator lights.....check 3 green lights

### NOTE

If the landing gear is correctly extended and locked, as indicated by the 3 green lights, the red light is illuminated additionally if the GEAR circuit breaker is pulled.

***If the landing gear cannot be extended to the down and locked position or red light does not extinguish:***

- I Continue according to [03-27 - Landing with Gear Up - Emergency operation procedure](#).

## 03-24 Landing with A Defective Tire on the MLG

### Emergency operation procedure

#### 1 Landing with a Defective Tire on the MLG

##### CAUTION

A DEFECTIVE (E.G. BURST) TIRE IS NOT USUALLY EASY TO DETECT. THE DAMAGE NORMALLY OCCURS DURING TAKE-OFF OR LANDING, AND IS HARDLY NOTICEABLE DURING FAST TAXIING. IT IS ONLY DURING THE ROLL-OUT AFTER LANDING OR AT LOWER TAXIING SPEEDS THAT A TENDENCY TO SWERVE OCCURS. RAPID AND DETERMINED ACTION IS THEN REQUIRED.

- A Advise ATC.
- B Land the airplane at the edge of the runway that is located on the side of the intact tire, so that changes in direction which must be expected during roll-out due to the braking action of the defective tire can be corrected on the runway.
- C Land with one wing low. The wing on the side of the intact tire should be held low.
- D Direction should be maintained using the rudder. This should be supported by use of the brake. It is possible that the brake must be applied strongly - if necessary to the point where the wheel locks. The wide track of the landing gear will prevent the airplane from tipping over a wide speed range. There is no pronounced tendency to tip even when skidding.

## 03-25 Landing with Defective Brakes

### Emergency operation procedure

#### 1 Landing with Defective Brakes

In general, a landing on grass is recommended in order to reduce the landing run due to the greater rolling resistance.

**WARNING**  
**IF SUFFICIENT TIME IS REMAINING, THE RISK OF FIRE IN THE**  
**EVENT OF A COLLISION CAN BE REDUCED AS FOLLOWS**  
**AFTER A SAFE TOUCH-DOWN:**

- A FUEL valve.....OFF
- B ENGINE MASTER.....OFF
- C EMERGENCY FUEL PUMP switch.....OFF
- D FUEL TRANS. switch.....OFF
- E ELECT. MASTER.....OFF

## 03-26 Landing Gear Unsafe Warning

### Emergency operation procedure

## 1 LANDING GEAR UNSAFE WARNING

### NOTE

The landing gear unsafe warning light illuminates, if the landing gear is neither in the final up or down and locked position. Illumination of this light is therefore normal during transit.

### NOTE

If the landing gear cannot be retracted to the final up position, you may continue the flight with the landing gear extended in the down and locked position. Consider for higher aerodynamic drag, resulting in degraded flight performance, increased fuel consumption and decreased range. With the landing gear extended and at aft CG-locations, with flaps up and full power applied, the airplane will easily recover from sideslip if the trim is set to neutral (normal procedure). Otherwise it may require corrective action with a moderate amount of rudder input. In cold ambient temperatures it may help to reduce the airspeed below 102 KIAS for landing gear operation.

### ***If the light remains on for longer than 20 seconds during landing gear retraction / extension***

- A    Airspeed.....check below  $v_{LO} = 162$  KIAS  
 B    Gear selector.....re-cycle if continued illumination occurs

### ***If the landing gear cannot be extended to the down and locked position or red light does not extinguish***

- C    Continue with [03-23 - Emergency Gear Extension - Emergency operation procedure](#).

## 03-27 Landing with Gear Up Emergency operation procedure

### 1 Landing with Gear Up

#### NOTE

This procedure applies, if the landing gear is completely retracted.

- A Approach.....with power at normal approach airspeeds and flap settings
- B Sun visors (if installed).....locked in fully upward position
- C PFD/MFD control unit (keypad) (if installed).....stowed
- D POWER lever.....Flight Idle (FI) / just before touchdown

***If the time / situation allows, the following steps can help to reduce the risk of fire***

- E ENGINE MASTER.....OFF
- F EMERGENCY FUEL PUMP switch.....check OFF
- G FUEL TRANS. switch.....check OFF
- H FUEL valve.....OFF

#### ***Touchdown***

- I Touchdown.....contact surface with minimum airspeed
- J On ground.....maintain directional control with rudder as long as possible so as to avoid collision with obstacles

#### ***Immediately after touchdown***

#### NOTE

If the ELECT. MASTER is switched OFF before touchdown, the landing gear will extend slowly.

- K ELECT. MASTER.....OFF

# FAILURES IN THE ELECTRICAL SYSTEM

## 03-28 Complete Failure of the Electrical System

### Emergency operation procedure

#### 1 Complete Failure of the Electrical System

- A Circuit breakers.....all in
- B ESSENTIAL BUS.....ON
- C Electrical equipment.....switch OFF all equipment which is not needed
- D Land on the nearest suitable airfield.

Be prepared for an engine failure and an emergency landing in accordance with [03-41 - Emergency Landing with Engine Off - Emergency operation procedure](#).



# SMOKE AND FIRE

**03-29 Engine Fire on Ground**  
**Emergency operation procedure**

**1 Engine Fire on Ground**

- A ENGINE MASTER.....OFF
- B FUEL valve.....OFF
- C ELECT. MASTER.....OFF

***After Standstill***

- D Door.....open
- E Airplane .....evacuate immediately

**03-30 Electrical Fire with Smoke on Ground**  
**Emergency operation procedure**

**1 Electrical Fire with Smoke on Ground**

A ELECT. MASTER.....OFF

***If the Engine Is Running***

B POWER lever.....Ground Idle (GI)

C ENGINE MASTER.....OFF

D FUEL valve.....OFF (lift and turn)

***When the Engine Has Stopped***

E Door.....open

F Airplane.....evacuate immediately

**03-31 If Take-Off Can Be Aborted**  
**Emergency operation procedure**

**1 Smoke and Fire During Take-Off**

***If Take-Off Can Still Be Aborted***

- A POWER lever.....Ground Idle (GI)
- B ECS shut-off.....PULL
- C Brakes.....apply - bring the airplane to a stop
- D ENGINE MASTER.....OFF
- E FUEL valve.....OFF (lift and turn)
- F ELECT. MASTER.....OFF

***After Standstill***

- G Door.....open
- H Airplane.....evacuate immediately

## 03-32 If Take-Off CANNOT Be Aborted

### Emergency operation procedure

#### 1 Smoke and Fire During Take-Off

##### If Take-Off CANNOT Be Aborted

#### WARNING

IF, IN THE EVENT OF AN ENGINE PROBLEM OCCURRING DURING TAKE-OFF, THE TAKE-OFF CAN NO LONGER BE ABORTED AND A SAFE HEIGHT HAS NOT BEEN REACHED, THEN A STRAIGHT-AHEAD EMERGENCY LANDING SHOULD BE CARRIED OUT. DO NOT ATTEMPT TO TURN BACK TO THE AIRFIELD. TURNING BACK CAN BE FATAL. REFER TO [03-16 - ENGINE FAILURE DURING TAKE-OFF - EMERGENCY OPERATION PROCEDURE](#).

- A ECS shut-off.....PULL
- B If possible, fly along a short-cut traffic circuit and land on the airfield.

##### ***After Climbing to a Height From Which the Selected Landing Area Can Be Reached Safely***

- C ENGINE MASTER.....OFF
- D FUEL valve.....OFF
- E ELECT. MASTER.....OFF
- F Emergency windows.....open if necessary
- G Perform an emergency landing with engine off. Allow for increased landing distance due to the flap position.  
Refer to [03-41 - Emergency Landing with Engine Off - Emergency operation procedure](#).

##### ***When Airplane Has Stopped***

- H Doors.....open
- I Airplane.....evacuate immediately

# 03-33 Engine Fire in Flight Emergency operation procedure

## 1 Engine Fire in Flight

### WARNING

**IN THE EVENT OF SMOKE OR FIRE, PREPARE TO LAND THE AIRPLANE WITHOUT DELAY WHILE COMPLETING FIRE SUPPRESSION AND/OR SMOKE EVACUATION PROCEDURES. IF IT CANNOT BE VISUALLY VERIFIED THAT THE FIRE HAS BEEN COMPLETELY EXTINGUISHED, WHETHER THE SMOKE HAS CLEARED OR NOT, LAND IMMEDIATELY.**

- A CIRCULATING AIR.....OFF / FRESH AIR
- B ECS shut-off.....PULL
- C Select appropriate emergency landing area.
- D ENGINE MASTER.....OFF
- E FUEL valve.....OFF
- F ELECT. MASTER.....OFF
- G Airspeed.....as required, if possible  
select a faster airspeed to try to put out the fire
- H Emergency Windows.....OPEN if required
- I Perform an emergency landing without engine power in accordance with [03-41 - Emergency Landing with Engine Off - Emergency operation procedure](#).

### ***When Airplane Has Stopped***

- J Doors.....open
- K Airplane.....evacuate immediately

**03-34 Electrical Fire with Smoke in Flight**  
**Emergency operation procedure**

**1 Electrical Fire in Flight**

**WARNING**

**IN THE EVENT OF SMOKE OR FIRE, PREPARE TO LAND THE AIRPLANE WITHOUT DELAY WHILE COMPLETING FIRE SUPPRESSION AND/OR SMOKE EVACUATION PROCEDURES. IF IT CANNOT BE VISUALLY VERIFIED THAT THE FIRE HAS BEEN COMPLETELY EXTINGUISHED, WHETHER THE SMOKE HAS CLEARED OR NOT, LAND IMMEDIATELY.**

A AVIONIC MASTER.....OFF

**WARNING**

**SWITCHING OFF THE ELECT. MASTER WILL LEAD TO TOTAL FAILURE OF ALL ELECTRONIC AND ELECTRIC EQUIPMENT.**

B ELECT. MASTER.....OFF

C CIRCULATING AIR.....FRESH AIR

D ECS shut-off.....PULL

E Emergency Windows.....OPEN if required

F Perform a precautionary landing on the nearest airfield.

***When Airplane Has Stopped***

G Doors.....open

H Airplane.....evacuate immediately

## OTHER EMERGENCIES



# 03-35 Unintentional Flight Into Icing Conditions

## Emergency operation procedure

### 1 Unintentional Flight Into Icing Conditions

#### *Unintentional Flight Into Icing Conditions*

- A Leave the icing area (by changing altitude or turning back in order to reach zones with a higher ambient temperature).
- B PITOT/STALL HEAT.....ON
- C Cabin heat.....ON
- D Cabin air.....DEFROST
- E POWER lever.....increase power, in order to prevent ice build-up on the propeller blades apply power changes periodically
- F ALTERNATE AIR.....OPEN
- G Alternate static.....OPEN
- H Emergency windows.....open if required

#### **CAUTION**

ICE BUILD-UP INCREASES THE STALLING SPEED.

#### **CAUTION**

WHEN THE PITOT HEATING FAILS EXPECT LOSS OF AIRSPEED INDICATION.

- I ATC.....advise if an emergency is expected

## 03-36 Suspicion of Carbon Monoxide Contamination in the Cabin

### Emergency operation procedure

#### 1 Suspicion of Carbon Monoxide Contamination in the Cabin

Carbon monoxide (CO) is a gas which is developed during the combustion process. It is poisonous and without smell. Since it occurs however usually together with flue gases, it can be detected. Increased concentration of carbon monoxide in closed spaces can be fatal. The occurrence of CO in the cabin is possible only due to a defect. If a smell similar to exhaust gases is noticed in the cabin, the following measures should be taken:

- A ECS FAN.....OFF
- B CIRCULATING AIR.....FRESH air
- C ECS shut-off.....PULL
- D Emergency windows.....open

## 03-37 Recovery from Spin

### Emergency operation procedure

#### 1 Recovery from Spin

#### CAUTION

STEPS A TO D MUST BE CARRIED OUT **IMMEDIATELY** AND **SIMULTANEOUSLY**.

- A POWER lever.....Flight Idle (FI)
- B Ailerons.....neutral
- C Rudder.....full deflection against direction of spin
- D Elevator (control stick).....forward

#### ***When rotation has stopped:***

- E Rudder.....neutral
- F FLAPS.....UP
- G Elevator (control stick).....pull carefully
- H Return the airplane from a descending into a normal flight attitude.
- I Do not exceed the "never exceed speed",  $V_{NE}$ .

**03-38 Gliding**  
**Emergency operation procedure**

**1 Gliding**

**NOTE**

The glide ratio is 10; i.e., for every 1000 ft (~300 m) of altitude loss the maximum horizontal distance traveled in still air is 1.6 NM (~ 3.0 km). During this the propeller will continue to windmill.

- A FLAPS.....UP
- B Gear.....UP
- C COWL FLAP.....CLOSED
- D Airspeed.....94 KIAS

**03-39 Emergency Descent**  
**Emergency operation procedure**

**1 Emergency Descent**

A FLAPS.....UP

**WARNING**  
**MAX. LANDING GEAR EXTENDED SPEED  $V_{LE}/V_{LO} = 162$  KIAS.**

B Airspeed.....not above 162 KIAS

C Gear.....DOWN

D POWER lever.....Flight Idle (FI)

## 03-40 Emergency Exit

### Emergency operation procedure

#### 1 Emergency Exit

- A In case of a roll over of the airplane on ground, the emergency exit is at the RH side of the PAX row. The red release belt is located at the upper rear corner of the emergency exit window. For activation follow instructions as placarded.

In case the emergency exit is blocked, the egress hammer may be used to break through the windows.

---

## 03-41 Emergency Landing with Engine Off

### Emergency operation procedure

#### 1 Emergency Landing with Engine Off

- A POWER lever.....Flight Idle (FI)
- B ENGINE MASTER.....OFF
- C PFD/MFD control unit (keypad) (if installed).....stowed
- D FUEL valve.....OFF
- E Airspeed, Landing Gear, Flaps.....as required

#### ***Before touchdown***

- F Belts and Harnesses.....fasten
- G Sun visors (if installed).....locked in fully upward position
- H Doors.....unlatch
- I ELECT. MASTER.....OFF

## 03-42 Autopilot or Electric Trim Malfunction / Failure

### Emergency operation procedure

#### 1 Autopilot or Electric Trim Malfunction / Failure

#### NOTE

An autopilot or electric trim malfunction may be recognized by an unexpected deviation from the desired flight path, abnormal flight control or trim wheel movement, or flight director commands which cause unexpected or contradictory information on the other cockpit displays. It may be accompanied by the aural autopilot disconnect tone, a red AFCS, red PTCH, red ROL, red YAW, red AP or yellow AP indication on the PFD, or a yellow CHECK ATTITUDE on the PFD. The autopilot and AHRS monitors normally detect failures and automatically disconnect the autopilot.

Failure of the electric pitch trim, indicated by a red boxed PTRM flashing on the PFD, may not cause the autopilot to disconnect. Be alert to possible autopilot out of trim conditions (see AUTOPILOT OUT OF TRIM procedure below), and expect residual control forces upon disconnect. The autopilot will not re-engage after disconnect with failed pitch trim. If AUTOPILOT OUT OF TRIM ELE indication is present, expect substantial elevator forces on autopilot disconnect.

#### NOTE

Accomplish [step A](#) and [step B](#) simultaneously!

- A Airplane control stick.....grasp firmly and regain airplane control
- B AP DISC switch.....depress and hold
- C Trim.....retrim airplane manually as required
- D AFCS / ESP circuit breaker.....pull
- E AP DISC switch.....release

#### WARNING

**DO NOT ATTEMPT TO RE-ENGAGE THE AUTOPILOT FOLLOWING AN AUTOPILOT, AUTOTRIM, OR MANUAL ELECTRIC TRIM MALFUNCTION UNTIL THE CAUSE FOR THE MALFUNCTION HAS BEEN CORRECTED.**

#### NOTE

When the AFCS / ESP circuit breaker is pulled, the manual electric trim and autopilot autotrim systems will be disabled. The steps of disengaging the autopilot should be committed to memory and the pilot should be able to accomplish all steps without reference to a manual or other pilot documentation.



# 03A

## ABNORMAL OPERATING PROCEDURES

# AIRPLANE RELATED CAS CAUTIONS

## 03A-01 Airplane related G1000 Caution Messages

### Emergency operation procedure

#### 1 Crew Alert System (CAS) Caution Messages

CAS Message	Cause	Corrective Action
<b>ALTN 1 FAIL</b>	Engine alternator 1 has failed.	See <a href="#">03A-02 - ALTN 1 FAIL - Special operation.</a>
<b>ALTN 2 FAIL</b>	Engine alternator 2 has failed.	See <a href="#">03A-03 - ALTN 2 FAIL - Special operation.</a>
<b>ALTN 1 FAIL</b>  AND  <b>ALTN 2 FAIL</b>	Engine alternator 1 AND engine alternator 2 have failed.	See <a href="#">03-06 - ALTN 1/2 FAIL - Emergency operation procedure.</a>
<b>CHECK GEAR</b>	Landing gear is not down and locked during approach.	See <a href="#">03A-04 - CHECK GEAR - Special operation.</a>
<b>COOLANT LVL</b>	Coolant level low.	See <a href="#">03A-05 - COOLANT LVL - Special operation.</a>
<b>ECU A FAIL</b>	Engine ECU A has failed.	See <a href="#">03A-06 - ECU A FAIL - Special operation.</a>
<b>ECU B FAIL</b>	Engine ECU B has failed.	See <a href="#">03A-07 - ECU B FAIL - Special operation.</a>
<b>ENG INTAKE</b>	Engine air intake temperature is above 70 °C.	See <a href="#">03A-13 - ENG INTAKE - Special operation.</a>
<b>FUEL LOW</b>	Main tank fuel quantity is below 4 ± 1 US gal usable fuel.	See <a href="#">03A-08 - FUEL LOW - Special operation.</a>
<b>PITOT FAIL</b>	Pitot heat has failed.	See <a href="#">03A-09 - PITOT HEAT FAIL / PITOT HEAT OFF - Special operation.</a>
<b>PITOT HT OFF</b>	Pitot heat is off.	See <a href="#">03A-09 - PITOT HEAT FAIL / PITOT HEAT OFF - Special operation.</a>

CAS Message	Cause	Corrective Action
<b>STALL HT FAIL</b>	Stall warning heat has failed.	See 03A-10 - STALL HT FAIL / STALL HT OFF - Special operation.
<b>STALL HT OFF</b>	Stall warning heat is off.	See 03A-10 - STALL HT FAIL / STALL HT OFF - Special operation.
<b>VOLTS LOW</b>	Essential bus voltage is below 25 V.	See 03A-11 - VOLTS LOW - Special operation.
<b>STALL WARN FAIL</b>	Stall warning system has failed.	See 03A-12 - STALL WARN FAIL - Special operation.

### 03A-02 ALTN 1 FAIL

#### Special operation

## 1 Alternator 1 Failure

**ALTN 1 FAIL**

Engine alternator 1 has failed.

- A Circuit breakers.....check if all OK (pressed in)
- B Alternator 1 switch.....OFF

#### NOTE

By switching the essential bus ON, alternator 2 supplies electrical power to the main and essential bus and charges the main battery. Electrical equipment connected to Alternator 2 (e.g. RACC system) will loose power.

- C ESSENTIAL BUS.....ON
- D Bus voltage.....monitor
- E NVFR or IFR operation.....terminate, land on the next suitable airfield

## 03A-03 ALTN 2 FAIL

### Special operation

#### 1 Alternator 2 Failure

**ALTN 2 FAIL**

Engine alternator 2 has failed.

- A Circuit breakers.....check if all OK (pressed in)
- B Alternator 2 switch.....OFF
- C Bus voltage.....monitor
- D NVFR or IFR operation.....terminate, land on the next suitable airfield

## 03A-04 CHECK GEAR

### Special operation

## 1 CHECK GEAR

**CHECK GEAR**

Landing gear retracted.

### NOTE

The CHECK GEAR caution message is displayed when either the flaps are in LDG position or the POWER lever is set to less than approx. 20% and the landing gear is not down and locked.

A Landing gear.....down / as required

## 03A-05 COOLANT LVL

### Special operation

#### 1 COOLANT LVL

#### COOLANT LVL

Coolant level is low.

A low coolant caution alert may indicate a loss of coolant. This will subsequently lead to decreased engine cooling capability / loss of engine power due to engine failure.

#### NOTE

The indication is calibrated for straight and level flight. The caution message may be triggered during turns which are flown with slip, or while taxiing in curves.

A Annunciations / Engine instruments.....monitor

See [03-07 - COOLANT TEMP - Emergency operation procedure](#).



## 03A-06 ECU A FAIL

### Special operation

## 1 ECU A FAIL

### ECU A FAIL

Engine ECU A has detected a failure.

#### ***On Ground***

- A Terminate flight preparation.

#### ***In Flight***

- B ALTERNATE AIR.....OPEN  
 C EMERGENCY FUEL PUMP switch.....ON  
 D Circuit breakers.....check / reset if necessary

#### **NOTE**

In case of a failure in the electronic ECU (Engine Control Unit) 'A' the system automatically switches to ECU 'B'.

- E FADEC TEST button.....press for more than 2 seconds  
 to reset the caution message

#### ***If the ECU A FAIL caution re-appears or cannot be reset***

- F Land on nearest suitable airfield.  
 G The engine must be serviced after landing.

#### ***If the ECU A FAIL caution can be reset***

- H Continue flight.  
 I The engine must be serviced after landing.

## 03A-07 ECU B FAIL

### Special operation

## 1 ECU B FAIL

### ECU B FAIL

Engine ECU B has detected a failure.

#### ***On Ground***

- A Terminate flight preparation.

#### ***In Flight***

- B ALTERNATE AIR.....OPEN
- C EMERGENCY FUEL PUMP switch.....ON
- D Circuit breakers.....check / reset if necessary
- E FADEC TEST button.....press for more than 2 seconds  
to reset the caution message

#### ***If the ECU B FAIL caution re-appears or cannot be reset***

- F Land on nearest suitable airfield.
- G The engine must be serviced after landing.

#### ***If the ECU B FAIL caution can be reset***

- H Continue flight.
- I The engine must be serviced after landing.

### 03A-08 FUEL LOW

#### Special operation

## 1 FUEL LOW

**FUEL LOW**

Main tank fuel quantity is low.

#### WARNING

**WHEN THE FUEL PUMP TAKES IN AIR (E.G. WHEN THE EMERGENCY FUEL VALVE IS NOT SWITCHED BACK AND THE AUXILIARY TANK IS EMPTY), AN INSPECTION OF THE PUMP IS NECESSARY PRIOR TO NEXT FLIGHT.**

#### CAUTION

AS SOON AS THE AMOUNT OF USABLE FUEL IN THE MAIN TANK IS LESS THAN 4 US GAL (+/-1 US GAL), A CAUTION MESSAGE IS DISPLAYED. THE INDICATION IS CALIBRATED FOR STRAIGHT AND LEVEL FLIGHT. THE CAUTION MESSAGE MAY BE TRIGGERED DURING TURNS WHICH ARE FLOWN WITH SLIP, OR WHILE TAXIING IN CURVES.

A FUEL TRANS. switch.....ON

B Fuel quantity.....check

***If the caution light does not extinguish***

C Expect loss of fuel.

D Be prepared for an emergency landing. Proceed in accordance with [03-41 - Emergency Landing with Engine Off - Emergency operation procedure.](#)

## 03A-09 PITOT HEAT FAIL / PITOT HEAT OFF

### Special operation

#### 1 PITOT FAIL / PITOT HT OFF

**PITOT FAIL**

**PITOT HT OFF**

Pitot heat has failed. / Pitot heat is off.

A PITOT/STALL HEAT.....check ON / as required

#### NOTE

The PITOT HT OFF caution message is displayed when the Pitot heating is switched OFF, or PITOT FAIL when there is a failure of the Pitot heating system. Prolonged operation of the Pitot heating on the ground can also cause the Pitot heating caution message to be displayed.

#### ***If in Icing Conditions***

- B Expect loss of airspeed indicators.
- C Leave icing zone. Refer to [03-35 - Unintentional Flight Into Icing Conditions - Emergency operation procedure](#).

## 03A-10 STALL HT FAIL / STALL HT OFF

### Special operation

#### 1 STALL HT FAIL / STALL HT OFF

**STALL HT FAIL**

**STALL HT OFF**

Stall warning heat has failed. / Stall warning heat is off.

A PITOT/STALL HEAT.....check ON / as required

#### NOTE

The STALL HT OFF caution message is displayed, when the Pitot heating is switched OFF. STALL HT FAIL is displayed when there is a failure of the stall warning heating system. Operation of the stall warning heating on the ground also causes the stall warning heating failed caution message to be displayed. In this case it indicates the activation of the thermal protection relay, which prevents overheating of the stall warning heating system on the ground. This is a normal function of the system.

#### ***If in Icing Conditions***

- B Expect loss of acoustic stall warning.
- C Leave icing zone. Refer to [03-35 - Unintentional Flight Into Icing Conditions - Emergency operation procedure](#).

## 03A-11 VOLTS LOW

### Special operation

## 1 VOLTS LOW

### **VOLTS LOW**

Essential bus voltage is below 25 V.

Possible reasons are:

- a fault in the power supply
- RPM too low.

#### **On Ground**

- A Circuit breakers.....check
- B POWER lever.....increase RPM

#### **If the caution light does not extinguish**

- C Terminate flight preparation.

#### **In Flight**

- D Circuit breakers.....check
- E Electrical equipment.....OFF if not needed

#### **If the caution light does not extinguish**

- F Follow procedure in [03A-02 - ALTN 1 FAIL - Special operation](#).

#### **During Landing**

- G Continue Approach, perform landing.

## 03A-12 STALL WARN FAIL

### Special operation

#### 1 STALL WARN FAIL

##### **STALL WARN FAIL**

Stall warning system has failed.

#### **NOTE**

The STALL WARN FAIL caution message is displayed when the stall warning computer detects a failure of the stall warning system.

- A Loss of acoustic stall warning.
- B Continue flight while exercising caution when flying at lower airspeeds due to missing stall warning. Use careful airspeed control and take into account the increased stalling speeds during banked flight as per [05-05 - Stalling Speeds - Description](#) .

## 03A-13 ENG INTAKE

### Special operation

#### 1 Engine Air Intake Temperature High

**ENG INTAKE**

Engine air intake temperature is high (above 70 °C) for more than 30 seconds.

High engine intake temperatures leads to reduces power output.

- A POWER.....reduce
- B COWL FLAP.....check open
- C Airspeed.....increase
- D Check if ENG INTAKE Caution extinguishes.



# ABNORMAL PROCEDURES

## 03A-14 Failure in the Electrical Rudder Trim System

### Special operation

#### Failure in Electrical Rudder Trim Indication or Function

A Rudder trim movement.....check via indication on PFD and actuation

#### ***In case of indication failure***

B Rudder trim.....adjust as required

#### ***In case of functional failure***

C Airplane attitude.....maintain/regain airplane control,  
use attitude indicator if necessary

D Airspeed..... use convenient airspeed and power setting

#### **NOTE**

Depending on rudder trim tab stuck position it might be necessary to bank/slip slightly to reduce required prolonged forces on rudder pedal.

#### **CAUTION**

A MAX. OF 3° BANK ANGLE, CORRESPONDING TO 3/4 BALL OFF CENTRE IS ALLOWED FOR PROLONGED FORCES ON RUDDER PEDAL.

#### **NOTE**

If the situation allows, the circuit breaker "RUDDER TRIM" can be pulled.

## 03A-15 Failure in Flap Operating System

### Special operation

## 1 FAILURE IN FLAP OPERATING SYSTEM

### ***Failure in Position Indication or Function***

- A FLAPS position.....check visually
- B Airspeed.....keep in white sector (max. 121 KIAS)
- C FLAPS switch.....re-check all positions

### ***Modified Approach Procedure Depending on the Available Flap Setting***

- D For landing distances with abnormal flap positions refer to:

1600 kg	<a href="#">05-30 - Landing Distances - Abnormal Flap Position</a>	1600 kg - Description
1800 kg	<a href="#">05-29 - Landing Distances - Abnormal Flap Position</a>	1800 kg - Description
1999 kg	<a href="#">05-28 - Landing Distances - Abnormal Flap Position</a>	1999 kg - Description

### ***If only UP available***

- E Airspeed.....84 KIAS up to 1600 kg (3527 lb)  
90 KIAS above 1600 kg (3527 lb)  
up to 1800 kg (3968 lb)  
94 KIAS above 1800 kg (3968 lb)
- F Land at a flat approach angle, use POWER lever to control airplane speed and rate of descent.

### ***If only T/O available***

- G Airspeed.....77 KIAS up to 1600 kg (3527 lb)  
79 KIAS above 1600 kg (3527 lb)  
up to 1800 kg (3968 lb)  
85 KIAS above 1800 kg (3968 lb)
- H Land at a flat approach angle, use POWER lever to control airplane speed and rate of descent.

### ***If only LDG available***

- I Perform normal landing.

## 03A-16 Before Starting Engine with External Power

### Special operation

#### 1 Before Starting Engine with External Power

A	Pre-flight inspection.....	complete
B	Rudder pedals.....	adjusted and locked
C	Passengers.....	instructed
D	Safety harnesses.....	all fastened
E	Doors.....	closed and locked
F	Door locks.....	unlocked, key removed
G	Parking brake.....	set
H	Flight controls.....	free movement
I	Gear lever.....	check DOWN
J	Trim wheel.....	T/O
K	POWER lever.....	check Ground Idle (GI)
L	Friction device on POWER lever.....	adjusted
M	Alternate air.....	check CLOSED
N	Emergency gear extension lever.....	check pushed in
O	Alternate static valve.....	check CLOSED
P	FADEC.....	check AUTO
Q	EMERGENCY FUEL PUMP switch.....	check OFF
R	ELECT. MASTER.....	check OFF
S	AVIONIC MASTER.....	check OFF

#### CAUTION

WHEN SWITCHING THE EXTERNAL POWER UNIT ON, THE ELECTRICALLY DRIVEN HYDRAULIC GEAR PUMP MAY ACTIVATE ITSELF FOR 5 TO 20 SECONDS IN ORDER TO RESTORE THE SYSTEM PRESSURE. SHOULD THE PUMP CONTINUE TO OPERATE CONTINUOUSLY OR PERIODICALLY, TERMINATE FLIGHT. THERE IS A MALFUNCTION IN THE LANDING GEAR SYSTEM.

T	External power.....	connect
U	ELECT. MASTER.....	ON
V	G1000 NXi.....	wait until power-up completed.

Press ENT on MFD to acknowledge

W COOLANT LVL caution.....check OFF

X Fuel temperature.....check

**WARNING**  
**NEVER ROTATE THE PROPELLER BY HAND.**

**03A-17 Starting Engine with External Power**  
**Special operation**

**1 Starting Engine with External Power**

**WARNING**

**IF THE OIL PRESSURE HAS NOT MOVED FROM THE RED RANGE WITHIN 3 SECONDS AFTER STARTING, SET THE ENGINE MASTER SWITCH TO OFF AND INVESTIGATE PROBLEM.**

**CAUTION**

**DO NOT OPERATE THE ENGINE STARTER MOTOR FOR MORE THAN 10 SECONDS, BECAUSE OF POSSIBLE OVERHEATING OF THE STARTER MOTOR.**

**IF THE STARTER ANNUNCIATION ON THE G1000 NXI COMES ON AFTER THE ENGINE HAS STARTED AND THE START BUTTON HAS BEEN RELEASED, SET THE ENGINE MASTER TO OFF AND INVESTIGATE THE PROBLEM.**

**NOTE**

At low ambient temperatures it is possible that the engine will not start at the first attempt. In this case wait 60 seconds between the start attempts.

- A Strobe lights (ACL).....ON
- B ENGINE MASTER.....ON
- C Annunciations / GLOW ON.....check ON

**NOTE**

GLOW ON is indicated only when the engine is cold.

- D Annunciations / engine indications.....check

***After the GLOW ON indication is extinguished***

**WARNING**

**BEFORE STARTING THE ENGINE THE PILOT MUST ENSURE THAT THE PROPELLER AREA IS FREE, AND NO PERSONS CAN BE ENDANGERED.**

- E START BUTTON.....PRESS as required / release when engine has started.
- F Annunciations / engine indications.....check OK/normal range
- G Annunciations / STARTER.....check OFF

- H Annunciations / Oil pressure.....check OK
- I Circuit breakers.....check all IN
- J Ground Idle (GI) RPM.....check, 660 RPM  
 (Ground Idle (GI) RPM might be higher in  
 certain environmental conditions)
- K External power.....disconnect
- L External power unit.....check disconnected and moved clear of the  
 airplane
- M Warm up.....Ground Idle (GI) for 2 min, then increase  
 Propeller  
 RPM to 1100 until engine temperatures are within  
 green range.
- N POWER lever.....Ground Idle (GI)
- O ENGINE MASTER.....OFF
- P Restart Engine according to [04-08 - Starting Engine - Pre-operation procedure](#).

### WARNING

**IF STARTING THE ENGINE IS NOT POSSIBLE USING BATTERY POWER, THE STATE OF CHARGE AND OPERABILITY OF THE BATTERY MUST BE VERIFIED BEFORE FLIGHT. IT IS NOT ALLOWED TO TAKE-OFF WITH AN EMPTY MAIN BATTERY OR WITH ANY DOUBT REGARDING THE STATE OF BATTERY CHARGE OF THE MAIN BATTERY.**

## 03A-18 Lightning Strike

### Special operation

### 1 LIGHTNING STRIKE

#### CAUTION

DUE TO POSSIBLE DAMAGE TO THE AIRPLANE OBEY THE FOLLOWING INSTRUCTIONS:

- AVOID ABRUPT OR FULL CONTROL SURFACE MOVEMENTS.
- AVOID HIGH G-LOADS ON THE AIRFRAME.
- AVOID HIGH YAW ANGLES.
- AVOID TURBULENT AIR AS FAR AS POSSIBLE (E.G. LEE EFFECTS).
- DO NOT FLY INTO AREAS OF KNOWN OR FORECAST ICING.

- A   Airspeed.....as low as practicable, do not exceed  $v_o$   
(refer to [02-02 - Airspeed Limitations - Description](#))
- B   Grasp airplane controls firmly.
- C   Autopilot (if installed).....disengage (check)
- D   PFD / Backup instruments.....verify periodically
- E   Continue flight below  $v_o$  (refer to [02-02 - Airspeed Limitations - Description](#)).
- F   Land on the next suitable airfield.



# 03A-19 Defective Fuel Transfer System

## Emergency operation procedure

### 1 Defective Fuel Transfer System

When switching on the fuel transfer pump, and the fuel transfer status light is not illuminated, monitor the fuel quantities. The transfer rate is 1 US gal per minute. If the fuel amount of the main tank is less than 17 US gal the fuel transfer can be activated. If fuel transfer from the auxiliary fuel tank to the main tank cannot be observed within a few minutes after switching on the transfer pump, assume a defective fuel transfer system.

A FUEL valve.....EMERGENCY

#### CAUTION

MAKE SURE NOT TO EXCEED THE FUEL IMBALANCE LIMITATIONS GIVEN IN [02-14 - FUEL - DESCRIPTION](#). WHEN MAX FUEL IMBALANCE IS REACHED SWITCH FUEL VALVE BACK TO NORMAL.

B FUEL valve.....NORMAL

#### NOTE

The procedure has to be repeated if required.

# AUTOPILOT FAILURES

**03A-20 Autopilot Disconnect**  
**Emergency operation procedure**

**1 AUTOPILOT DISCONNECT (yellow AP flashing on PFD)**

- A AP DISC switch.....depress and release  
(to cancel disconnect tone)
- B Pitch trim.....retrim if necessary, using  
the trim wheel

**NOTE**

The autopilot disconnect may be accompanied by a red boxed PTCH (pitch) or ROL on the PFD, indicating the axis which has failed. The autopilot cannot be re-engaged with either of these annunciations present.

**03A-21 Autopilot Overspeed Recovery**  
**Emergency operation procedure**

**1 AUTOPILOT OVERSPEED RECOVERY (yellow MAXSPD on PFD)**

A POWER lever.....reduce power

***When overspeed condition is corrected:***

B1 Autopilot.....reselect vertical mode (if necessary)

**NOTE**

Overspeed recovery mode provides a pitch up command to decelerate the airplane at or below the maximum autopilot operating speed (185 KIAS). Overspeed recovery is not active in altitude hold (ALT) or glideslope (GS) or glidepath (GP) modes.

**03A-22 Loss of Navigation Information**  
**Emergency operation procedure**

**1 LOSS OF NAVIGATION INFORMATION (Yellow VOR, VAPP, GPS or LOC flashing on PFD)**

**NOTE**

If a navigation signal is lost while the autopilot is tracking it, the autopilot will roll the airplane wings level and default to roll mode (ROL).

- A Autopilot.....select HDG on mode controller
- B CDI.....select a valid nav source
- C Autopilot.....select NAV on mode controller

***If on an instrument approach at the time the navigation signal is lost:***

- D Missed approach procedure.....execute (as applicable)

**03A-23 Autopilot Out Of Trim  
Emergency operation procedure**

**1 AUTOPILOT OUT OF TRIM (Yellow ←AIL, AIL→, ↑ELE, ↓ELE, ←RUD or RUD→ on PFD)**

***For ↑ELE, or ↓ELE Indication:***

***If the annunciation remains:***

**WARNING**

**DO NOT ATTEMPT TO OVERPOWER THE AUTOPILOT IN THE EVENT OF A PITCH MISTRIM. THE AUTOPILOT SERVOS WILL OPPOSE PILOT INPUT AND WILL CAUSE PITCH TRIM TO RUN OPPOSITE THE DIRECTION OF PILOT INPUT. THIS WILL LEAD TO A SIGNIFICANT OUT-OF-TRIM CONDITION RESULTING IN LARGE CONTROL STICK FORCE WHEN DISENGAGING THE AUTOPILOT.**

**CAUTION**

**BE PREPARED FOR SIGNIFICANT SUSTAINED CONTROL FORCES IN THE DIRECTION OF THE ANNUNCIATION ARROW. FOR EXAMPLE, AN ARROW POINTING DOWN INDICATES NOSE DOWN CONTROL STICK FORCE WILL BE REQUIRED UPON AUTOPILOT DISCONNECT.**

**NOTE**

Momentary illumination (5 sec or less) of the ↑ELE or ↓ELE indication during configuration or large airspeed changes is normal.

- A AP DISC switch.....depress and hold while grasping control stick firmly
- B Airplane attitude.....maintain / regain airplane control, use standby attitude indicator if necessary
- C Pitch trim .....retrim if necessary, using the trim wheel
- D AFCS / ESP circuit breaker.....pull

**WARNING**

**FOLLOWING AN AUTOPILOT, AUTOTRIM OR MANUAL ELECTRIC TRIM SYSTEM MALFUNCTION, DO NOT ENGAGE THE AUTOPILOT OR OPERATE THE MANUAL ELECTRIC TRIM UNTIL THE CAUSE OF THE MALFUNCTION HAS BEEN CORRECTED.**

E AP DISC switch.....release

**For ←AIL, AIL→ or ←RUD, RUD→ Indication:**

F Rudder trim.....verify slip / skid indicator is centered,  
trim is necessary

**NOTE**

Observe the maximum fuel imbalance limitation.

**If the annunciation remains:**

G Control stick.....grasp firmly with both hands

**CAUTION**

BE PREPARED FOR SUSTAINED CONTROL FORCES IN THE DIRECTION OF THE ANNUNCIATION ARROW. FOR EXAMPLE, AN AIL→ INDICATES THAT SUSTAINED RIGHT WING DOWN CONTROL STICK FORCE OR FOR RUD→ SUSTAINED RIGHT RUDDER FORCE WILL BE REQUIRED UPON AUTOPILOT DISCONNECT.

H AP DISC switch.....depress

I Autopilot.....re-engage if lateral trim is re-established

## 03A-24 Flashing Yellow Mode Annunciation

### Emergency operation procedure

## 1 FLASHING YELLOW MODE ANNUNCIATION

### NOTE

Abnormal mode transitions (those not initiated by the pilot or by normal sequencing of the autopilot) will be annunciated by flashing the disengaged mode in yellow on the PFD. Upon loss of a selected mode, the system will revert to the default mode for the affected axis, either ROL or PIT. After 10 seconds, the new mode (PIT or ROL) will be annunciated in green.

### ***Loss of Selected Vertical Mode (FLC, VS, ALT, GS)***

A Autopilot mode controls.....select another vertical mode

#### ***If on an instrument approach:***

B Autopilot.....disconnect and continue manually  
or execute missed approach

### ***Loss of Selected Lateral Mode (HDG, NAV, GPS, LOC, VAPP, BC):***

C Autopilot mode controls.....select another lateral mode

#### ***If on an instrument approach:***

D Autopilot.....disconnect and continue manually  
or execute missed approach



## 03A-25 Effects Of G1000 NXi Losses Upon Autopilot Operation

### Description

#### 1 EFFECTS OF G1000 NXi LOSSES UPON AUTOPILOT OPERATION

G1000 NXi System Loss	Effect upon Autopilot Operation
AHRS	The autopilot disconnects and autopilot, yaw damper and flight director are inoperative. Manual electric trim is available.
HDG function of AHRS	The autopilot will remain engaged with the loss of the HDG mode.
MFD	The autopilot will remain engaged in the last active mode. Controls are not available. Disengage by using the AP DISC switch.
PFD	The autopilot will remain engaged with no functional limitations.
GIA No. 1	The autopilot disconnects and autopilot, flight director and manual electric trim are inoperative.
GIA No. 2	The autopilot disconnects and autopilot and manual electric trim are inoperative. Flight director is available.
GPS No. 1 and 2	The autopilot and flight director operates in NAV modes only (LOC, BC, VOR, VAPP) with reduced accuracy.
ADC	The autopilot disconnects and autopilot is inoperative. The flight director is available except for air data modes (ALT, VS, FLC). Manual electric trim is available.

**Table 1 - Effects of G1000 NXi Losses upon Autopilot Operation**

**04**  
**NORMAL OPERATING PROCEDURES**

# NORMAL OPERATING PROCEDURES GENERAL

## 04-01 Normal Operating Procedures

### Description

#### 1 Introduction

This Chapter contains checklists and describes procedures for the normal operation of the airplane.

#### **NOTE**

Readability of the G1000 NXi PFD and MFD display may be degraded when wearing polarized sunglasses.

#### **NOTE**

Normal operating procedures for GFC 700 are described in the Garmin G1000 NXi Cockpit Reference Guide, P/N 190-02800-( ) and the Garmin G1000 NXi Pilot's Guide for the Diamond DA 50 C, P/N 190-02799-( ).

## 04-02 Flight Characteristics

### Description

#### 1 Flight Characteristics

The DA 50 C is to be flown with "the feet on the pedals", meaning that coordinated flight in all phases and configurations shall be supported by dedicated use of the rudder and ailerons together.

With the landing gear extended and at aft CG-locations, with flaps up and full power applied, the airplane will easily recover from sideslip if the trim is set to neutral (normal procedure), otherwise it may require corrective action with a moderate amount of rudder input.

## 04-03 Airspeeds for Normal Operation

### Description

#### 1 Airspeeds for Normal Operating Procedures

For all airspeed tables in the following Sections apply linear variations between weights.

Flight Mass	up to 1600 kg (3527 lb)	above 1600 kg (3527 lb) up to 1800 kg (3968 lb)	above 1800 kg (3968 lb)
Airspeed for rotation (Take-off run, $v_R$ ) (Flaps T/O)	59 KIAS	64 KIAS	68 KIAS
Airspeed for initial climb ( $v_{50 ft}$ ) (Flaps T/O)	69 KIAS	73 KIAS	79 KIAS
Airspeed for take-off climb (best rate-of-climb speed $v_Y$ ) (Flaps T/O)	79 KIAS		
Airspeed for cruise climb (Flaps UP)	94 KIAS		
Approach speed for normal landing (Flaps LDG)	73 KIAS	75 KIAS	77 KIAS
Minimum speed during go-around (Flaps T/O)	77 KIAS	79 KIAS	85 KIAS
Max. structural cruising speed Do not exceed this speed except in smooth air, and then only with caution. (Flaps UP)	152 KIAS		

Table 1 - Airspeeds

# DAILY CHECK

## 04-04 Daily Checks

### Pre-operation procedure

#### 1 Daily Check

Before the first flight of a day it must be ensured that the following checks are performed:

- On-condition check of the LH and RH pilot door and the passenger door for cracks and major scratches.
- On-condition check of the hinges for the LH and RH pilot door and the passenger door.
- Visual inspection of the locking bolts for proper movement with no backlash.
- Tire inflation pressure check (main wheels: 3.8 bar / 55 psi, nose wheel: 6.1 bar / 88 psi).
- Visual inspection of the spinner and its attachment (including screws).



# CHECKLISTS FOR NORMAL OPERATING PROCEDURES

## 04-05 Pre-Flight Inspection - Cabin Check

### Pre-operation procedure

#### 1 Pre-Flight Inspection - Cabin Check

##### Preparation

- A Pitot Cover.....removed
- B Parking brake.....set ON
- C MET, NAV, mass and balance.....flight planning completed
- D Airplane documents.....complete and up to date
- E LH and RH Pilot doors and passenger door..... clean, undamaged, check locking mechanism function
- F Baggage.....stowed and secured
- G Foreign objects.....check
- H Emergency Exit window.....remove pin and store in Pilot's or  
Co-Pilot's backrest pocket
- I Sun visors (if installed).....locked in fully upward position

##### Emergency equipment

- A Egress hammer.....stowed and secured
- B First aid kit.....stowed and secured
- C Fire extinguisher.....stowed and secured  
pressure in green arc
- D Equip. necessary by national operation rules.....stowed and secured

## Center console

- A FUEL valve.....check NORMAL
- B COWL FLAP.....check closed
- C POWER lever..... check condition, freedom of movement and full travel,  
set Ground Idle (GI)
- D PFD/MFD control unit (keypad) (if installed).....stowed

## Below instrument panel in front of left seat

- A Alternate Static Source.....check closed
- B Emergency gear extension lever.....check pushed in
- C ECS shut-off.....check pushed in / OPEN

## Below instrument panel in front of right seat

- A Alternate Air.....check closed

## On the instrument panel

- A FADEC.....check AUTO
- B Alternators 1 and 2.....check both ON
- C FUEL TRANS. switch.....check OFF
- D EMERGENCY FUEL PUMP switch.....check OFF
- E ENGINE MASTER.....check OFF
- F ESS Bus.....check OFF
- G AVIONIC MASTER.....check OFF
- H PITOT/STALL HEAT.....check OFF
- I GEAR selector.....check DOWN
- J FLAPS.....check UP
- K ELT.....armed

- L Circuit breakers.....check IN
- M All electrical equipment.....OFF

**Check procedure**

**CAUTION**

WHEN SWITCHING THE ELECT. MASTER ON, THE ELECTRICALLY DRIVEN HYDRAULIC GEAR PUMP MAY ACTIVATE ITSELF FOR 5 TO 20 SECONDS IN ORDER TO RESTORE THE SYSTEM PRESSURE. SHOULD THE PUMP CONTINUE TO OPERATE CONTINUOUSLY OR PERIODICALLY, TERMINATE FLIGHT PREPARATION. THERE IS A MALFUNCTION IN THE LANDING GEAR SYSTEM.

- A ELECT. MASTER.....ON
- B Fuel quantity.....check indication

**CAUTION**

DO NOT LOOK DIRECTLY INTO THE ANTI COLLISION LIGHTS.

- C Position lights, strobe lights (ACL).....check for correct function
- D Landing / Taxi light.....check for correct function

**WARNING**

**THE PITOT PROBE BECOMES VERY HOT DURING OPERATION. BE CAREFULL TO AVOID BURNS. THIS CAN CAUSE INJURIES TO PERSONS.**

**NOTE**

For maximum service life minimize heater operation during ground operation.

**NOTE**

Because the stall warning switch gets slightly warmer on ground, STALL HT FAIL may be indicated on the PFD.

- E PITOT/STALL HEAT, Stall Warning.....check

**CAUTION**

IF THE AURAL ALERT OR THE CAUTION ON THE PFD DOES NOT APPEAR, TERMINATE FLIGHT PREPARATION. UNSCHEDULED MAINTENANCE IS NECESSARY.

- F GEAR warning TOGGLE TO TEST switch.....TOGGLE, check aural alert and CHECK GEAR caution
- G STALL warning TOGGLE TO TEST switch.....TOGGLE, check aural alert and check that CAS message "STALL

WARN FAIL" is not indicated.

- H Electrical trim (rudder).....check indication and free and correct movement up to full deflection
- I COWL FLAP.....open
- J FLAPS.....LDG
- K Ventilation fan.....check ON/OFF
- L ELECT. MASTER.....OFF
- M Flight controls.....check free and correct movement up to full deflection  
 check aileron centering and elevator pull spring  
 (stick should move to aileron neutral, elevator at back stop position)
- N Elevator trim.....check free and correct movement up to full deflection

## 04-06 Pre-Flight Inspection - Walk Around Check

### Pre-operation procedure

#### 1 Pre-Flight Inspection - Walk Around Check, Visual Inspection

##### CAUTION

A VISUAL INSPECTION MEANS: EXAMINATION FOR DAMAGE, CRACKS, DELAMINATION, EXCESSIVE PLAY, LOAD TRANSMISSION, CORRECT ATTACHMENT AND GENERAL CONDITION. IN ADDITION CONTROL SURFACES SHOULD BE CHECKED FOR FREEDOM OF MOVEMENT.

##### CAUTION

IN LOW AMBIENT TEMPERATURES THE AIRPLANE MUST BE COMPLETELY CLEARED OF ICE, SNOW AND SIMILAR ACCUMULATIONS. FOR APPROVED CLEANING FLUIDS REFER TO CHAPTER 8 - [08-13 - CLEANING THE AIRCRAFT FROM ICE AND SNOW - DESCRIPTION](#).

##### CAUTION

AFTER PARKING IN TEMPERATURES BELOW 0 °C, NO FLOWING LIQUID UPON ACTIVATING THE DRAIN VALVES IS A SIGN OF FROZEN WATER IN THE FUEL SYSTEM. IN THIS CASE THE AIRPLANE MUST BE WARMED UP ABOVE 0 °C TO DRAIN WATER FROM THE FUEL SYSTEM.

##### CAUTION

PRIOR TO FLIGHT, REMOVE ITEMS SUCH AS CONTROL SURFACES GUST LOCK, PITOT COVER, TOW BAR, STEERING BAR, ETC.

#### Fuselage, Left Side

A LH pilot door.....Visual inspection

#### Left Main Landing Gear

A Landing gear strut and lock.....Visual inspection, sufficient height (typical visible length of bare piston: at least 5 cm (2.0 in))

- B Down and uplock switches.....Visual inspection
- C Wear, tread depth of tire.....Visual inspection
- D Tire, wheel, brake.....Visual inspection  
 Check discs for cracks and scoring  
 Check brake pad condition  
 Check callipers for free movement
- E Brake line connection.....Check for leaks
- F Slip marks.....Check alignment
- G Landing gear door.....Visual inspection

**Left Wing**

- A Entire wing surface.....Visual inspection
- B Tank drain/tank air inlet.....Drain off to check for water and sediment  
 drain until no water comes out)  
 visual inspection
- C Stall warn device.....Visual inspection
- D Openings on lower surface.....Check for foreign objects and for traces of fuel  
 (if tank is full, fuel may spill over through the tank vent)
- E Tank air outlet on lower surface.....Visual inspection
- F Tank filler.....Visual inspection, check closed
- G Vortex generators.....Undamaged, 10 pieces, clean
- H Pitot probe.....Clean, orifices clear, cover removed, no deformation
- I Wing tip.....Visual inspection
- J Position light, strobe light (ACL).....Visual inspection
- K Tie-down.....Check, clear
- L Static discharger.....Visual inspection
- M Aileron hinges and safety pin.....Visual inspection
- N Foreign objects in aileron paddle.....Visual inspection
- O Aileron and linkage cover.....Visual inspection
- P Flap (LDG position).....Linkages: visual inspection  
 Vanes: visual inspection  
 Hinge and linkage covers: visual inspection
- Q Step.....Visual inspection of attachment

## Fuselage, Left Side, Underside

A	Passenger door and window.....	Visual inspection
B	Fuselage skin.....	Visual inspection
C	Antennas.....	Visual inspection
D	Fuselage.....	Check for contamination (hydraulic fluid, fuel)
E	Drain holes fuselage.....	Check for liquids (water, TKS)
F	Trim weight container.....	Visual inspection
G	Trim weight container attachment screws.....	Visual inspection

## Empennage

A	Stabilizers and control surfaces, elevator tips.....	Visual inspection
B	Hinges.....	Visual inspection
C	Elevator trim tab.....	Visual inspection, check safetying
D	Rudder trim tab.....	Visual inspection, check safetying
E	Tie-down.....	Check, clear
F	Tail skid and lower fin.....	Visual inspection
G	Static dischargers (3).....	Visual inspection
H	Antennas.....	Visual inspection
I	Vortex generators.....	Undamaged, 12 pieces, clean on lower side of horizontal stabilizer

## Fuselage, Right Side

A	Fuselage skin .....	Visual inspection
B	Emergency exit window.....	Visual inspection, release handle cover remains closed.

## Right Main Landing Gear

A	Landing gear strut and lock.....	Visual inspection, sufficient height (typical visible)
---	----------------------------------	--



length of bare piston: at least 5 cm (2.0 in))

- B Down and uplock switches.....Visual inspection
- C Wear, tread depth of tire.....Visual inspection
- D Tire, wheel, brake.....Visual inspection
  - Check discs for cracks and scoring
  - Check brake pad condition
  - Check callipers for free movement
- E Brake line connection.....Check for leaks
- F Slip marks.....Check alignment
- G Landing gear door.....Visual inspection

**Right Wing**

- A Step.....Visual inspection of attachment
- B Flap (LDG position).....Linkages: visual inspection
  - Vanes: visual inspection
  - Hinge and linkage covers: visual inspection
- C Aileron and linkage cover.....Visual inspection
- D Foreign objects in aileron paddle.....Visual inspection
- E Aileron hinges and safety pin.....Visual inspection
- F Static discharger.....Visual inspection
- G Tie-down.....Check, clear
- H Position light, strobe light (ACL).....Visual inspection
- I Wing tip.....Visual inspection
- J Vortex generators.....Undamaged, 10 pieces, clean
- K Tank filler.....Visual inspection, check closed
- L Tank air outlet on lower surface.....Visual inspection
- M Openings on lower surface.....Check for foreign objects and for traces of fuel
  - (if tank is full, fuel may spill over through the tank vent)
- N Tank drain/tank air inlet.....Drain off to check for water and sediment
  - drain until no water comes out)
  - visual inspection
- O Entire wing surface.....Visual inspection
- P OAT sensor.....Check

**Front Fuselage, Engine Compartment, Nose Landing Gear**

A	RH pilot door.....	Visual inspection
B	EPU connector.....	Check
C	Cowling.....	Visual inspection
D	Compart. ventilation small NACA air intake.....	Clear (LH/RH rear cowling)
E	Exhaust.....	Visual inspection
F	COWL FLAP and linkages.....	Visual inspection
G	Nose landing gear strut and lock.....	Visual inspection, sufficient height (at least 5 cm (2.0 in))
H	Down and uplock switches.....	Visual inspection
I	Emergency nose gear extension spring.....	Visual inspection
J	Wear, tread depth of tire.....	Visual inspection
K	Slip marks.....	Visual inspection
L	Nose gear doors and linkages.....	Visual inspection
M	4 Engine air intakes / 2 air outlets.....	Clear

### WARNING

**NEVER MOVE THE PROPELLER BY HAND WHILE THE ENGINE MASTER SWITCH IS ON! ALSO DO NOT MOVE THE PROPELLER BY HAND WHILE THE ENGINE MASTER IS OFF IMMEDIATELY AFTER OPERATION (REMAINING PRESSURE IN THE INJECTION SYSTEM RAIL). SERIOUS PERSONAL INJURY MAY RESULT.**

N	Propeller.....	Visual inspection
O	2 Coolant radiators.....	Visual inspection (use flashlight if necessary)
P	2 Intercoolers.....	Visual inspection
Q	Gearbox oil level.....	Check visually (inspection cover on front side of cowling)
R	Engine oil level.....	Check dipstick (inspection cover on LH top side cowling)
S	Cockpit ventilation NACA air intake.....	Clear (LH rear cowling)
T	Gascolator.....	Drain off to check for water and sediment (drain until no water comes out) / clear
U	Chocks.....	Remove
V	Tow bar / Steering bar.....	Remove

**04-07 Before Starting Engine**  
**Pre-operation procedure**

**1 Before Starting the Engine**

- A Pre-flight inspection.....complete
- B Passengers.....instructed

Ensure all the passengers have been fully briefed on the location, operation and use

- of the seat belts, doors and backrest folding mechanism,
- of the emergency exits, emergency equipment (egress hammer, fire extinguisher and other equipment necessary by the operating rules) and their placarding,
- and the ban on smoking.

**CAUTION**

WHEN OPERATING THE DOORS, PILOTS/OPERATORS MUST ENSURE THAT THERE ARE NO OBSTRUCTIONS BETWEEN THE DOORS AND THE MATING FRAME, FOR EXAMPLE SEAT BELTS, CLOTHING, ETC. WHEN OPERATING THE LOCKING HANDLE DO NOT APPLY UNDUE FORCE. A SLIGHT DOWNWARD/INWARD PRESSURE ON THE DOORS MAY BE REQUIRED TO EASE THE HANDLE OPERATION.

**CAUTION**

FOR TAKE-OFF THE ADJUSTABLE BACKRESTS MUST BE FIXED IN THE UPRIGHT POSITION.

**NOTE**

In case of roll over of the airplane on ground, the emergency exit is at the RH side of the PAX row. The red release belt is located at the upper rear corner of the emergency exit window. For activation follow instructions as placarded.

- C Passenger door.....closed and locked
- D LH/RH Pilot door.....closed and locked
- E Adjustable backrests.....adjust to the upright position described by a placard on the roll-over bar and verify proper fixation
- F Safety harnesses.....all on and fastened
- G POWER lever.....check Ground Idle (GI)
- H Parking brake.....set

**CAUTION**

IF THE PROVISIONS FOR TABLET MOUNTS ARE INSTALLED ON THE LH AND RH A-COLUMN (OÄM-50-020 IS INSTALLED) AND A TABLET COMPUTER IS USED, THE PILOT MUST ENSURE THAT THE MOUNT IS ADJUSTED NOT TO INTERFERE WITH THE COCKPIT CONTROLS, TO PROVIDE SUFFICIENT OUTSIDE AND INSTRUMENTS VIEW AND NOT TO INTERFERE WITH THE CONTROL STICKS IN ANY POSITION.

- I GEAR selector.....check DOWN
- J AVIONIC MASTER.....check OFF
- K FADEC.....check AUTO
- L EMERGENCY FUEL PUMP switch.....check OFF
- M ALTERNATORS 1 and 2.....check both ON

**CAUTION**

WHEN SWITCHING THE ELECT. MASTER ON, THE ELECTRICALLY DRIVEN HYDRAULIC GEAR PUMP MAY ACTIVATE ITSELF FOR 5 TO 20 SECONDS IN ORDER TO RESTORE THE SYSTEM PRESSURE. SHOULD THE PUMP CONTINUE TO OPERATE CONTINUOUSLY OR PERIODICALLY, TERMINATE FLIGHT PREPARATION. THERE IS A MALFUNCTION IN THE LANDING GEAR SYSTEM.

- N ELECT. MASTER.....ON
- O Rudder pedals .....adjusted
- P COWL FLAP.....closed
- Q FLAPS.....Up

**NOTE**

The engine instruments are only available on the MFD after this item has been completed.

- R G1000 NXi.....wait until power-up completed, press ENT on MFD to acknowledge
- S Fuel temperature .....check
- T POWER lever.....check free movement, Ground Idle (GI)

**04-08 Starting Engine  
Pre-operation procedure**

**1 Starting Engine**

**CAUTION**

STARTER CRANKING ALLOWED FOR MAX. 3 SECONDS CONTINUOUS. WAIT AT LEAST 30 SECONDS BEFORE NEW ATTEMPT. AFTER 6 UNSUCCESSFUL RESTARTS, ALLOW 30 MINUTES FOR STARTER MOTOR COOLING.

No engine start should be attempted at outside air temperatures below -25°C. Oil temperature must be above -25°C.

Before starting the engine, ensure that the airplane battery is properly charged. If not, engine will not start and damage to starter and electrical power circuit may occur.

- A Strobe lights (ACL).....ON
- B ENGINE MASTER.....ON

**NOTE**

The glow plugs are supplied with power by a preheat relay before and during starting as well as after engine start. The FADEC is solely responsible for their activation.

- C Annunciators.....check GLOW ON
- D Annunciators.....check OK/normal range

***After the GLOW ON indication is extinguished:***

**WARNING**

**BEFORE STARTING THE ENGINE THE PILOT MUST ENSURE THAT THE PROPELLER AREA IS FREE, AND NO PERSONS CAN BE ENDANGERED.**

- E Propeller area.....check clear

### CAUTION

DO NOT OVERHEAT THE STARTER MOTOR. DO NOT OPERATE THE STARTER MOTOR FOR MORE THAN 3 SECONDS.

AT LOW AMBIENT TEMPERATURES IT IS POSSIBLE THAT THE ENGINE WILL NOT START AT THE FIRST ATTEMPT. IN THIS CASE WAIT 30 SECONDS BETWEEN THE START ATTEMPTS.

IF THE STARTER ANNUNCIATION COMES ON AFTER THE ENGINE HAS STARTED AND THE START PUSH BUTTON HAS BEEN RELEASED, SET THE ENGINE MASTER TO OFF AND INVESTIGATE THE PROBLEM.

- F ENGINE START button.....PRESS as required / release when engine has started  
 G Annunciations.....check OK/normal range  
 H Annunciations / Starter.....check OFF

### WARNING

**IF THE OIL PRESSURE HAS NOT REACHED 2.3 BAR AFTER 3 SECONDS SWITCH THE ENGINE OFF IMMEDIATELY.**

- I Annunciations / Oil pressure.....check OFF, check min 2.3 bar  
 J Circuit breakers.....check all in/as required  
 K Ground Idle RPM.....660 RPM

**04-09 Before Taxiing**  
**Pre-operation procedure**

**1 BEFORE TAXIING**

- A AVIONIC MASTER.....ON
- B Warm up.....Ground Idle (GI) for 2 min, then  
increase Propeller RPM to 1100  
until engine temperatures are in green range
- C Electrical equipment.....ON as required
- D Flight instruments and avionics.....set as required
- E Flood light.....ON, test function, as required

**NOTE**

The stall warning switch gets slightly warmer on ground only and STAL HT FAIL is indicated on the PFD.

- F PITOT/STALL HEAT.....ON, check annunciation
- G PITOT/STALL HEAT.....OFF
- H Strobe lights (ACL).....ON

**CAUTION**

WHEN TAXIING AT CLOSE RANGE TO OTHER AIRPLANES, OR DURING NIGHT FLIGHT IN CLOUDS, FOG OR HAZE, THE STROBE LIGHTS SHOULD BE SWITCHED OFF. THE POSITION LIGHTS MUST ALWAYS BE SWITCHED ON DURING NIGHT FLIGHT.

- I Position lights, landing and taxi lights.....as required
- J Primary flight display (PFD).....no autopilot annunciations
- K Autopilot disconnect tone.....note

**NOTE**

The AFCS system automatically conducts a preflight self-test upon initial power application. The preflight test is indicated by a white boxed PFT on the PFD. Upon successful completion of the preflight test, the PFT is removed, the red AFCS annunciation is removed, and the autopilot disconnect tone sounds. If AFCS annunciation remains on or a failure of the preflight test is indicated terminate flight preparation and investigate the problem.

- L Test the manual electric TRIM as follows:  
Press the AP DISC button down and hold while commanding trim (UP/DN).  
Manual electric trim should not operate either nose up or nose down.

- M Autopilot.....push AP button to engage
- N AP DISC switch.....push. verify that the autopilot disconnects
- O TRIM.....set to take-off position manually
- P Alternator 2 function test:
  - Alternator 1.....check Volts and Amps
  - ESS Bus.....ON

**NOTE**

For maximum service life minimize the duration of PITOT/STALL HEAT ON.

- PITOT/STALL HEAT.....ON
- Alternator 2.....Amps increase
- ESS Bus.....OFF
- Alternator 1.....Amps increase
- Alternator 2.....Amps decrease
- PITOT/STALL HEAT.....OFF



**04-10 Taxiing**  
**Pre-operation procedure**

**1 Taxiing**

**CAUTION**

WHEN TAXIING ON A POOR SURFACE SELECT THE LOWEST POSSIBLE RPM TO AVOID DAMAGE TO THE PROPELLER FROM STONES OR SIMILAR ITEMS.

**CAUTION**

AVOID PROLONGED PERMANENT BRAKING WHILE TAXIING. PROLONGED PERMANENT BRAKING WHILE TAXIING WILL OVERHEAT THE BRAKES AND MAY CAUSE LOSS OF BRAKE CAPACITY AND SUBSEQUENT DAMAGE TO THE AIRPLANE.

- A Parking brake.....release
- B Brakes.....test on moving off
- C Flight instrumentation and avionics.....check for correct indications
- D EMERGENCY FUEL PUMP switch.....check OFF
- E FUEL valve.....EMERGENCY
- F FUEL valve.....NORMAL

## 04-11 Before Take-Off

### Pre-operation procedure

#### 1 Before Take-Off

##### Before Take-Off Check

- A Position airplane into wind if possible.
- B Parking brake.....set

#### CAUTION

FOR TAKE-OFF THE ADJUSTABLE BACKRESTS MUST BE FIXED IN THE UPRIGHT POSITION.

- C Adjustable backrests.....verify upright position and proper fixation
- D Safety harnesses.....CHECK on and fastened
- E Sun visors (if installed).....locked in fully upward position
- F PFD/MFD control unit (keypad) (if installed).....stowed

#### CAUTION

WHEN OPERATING THE DOORS, PILOTS/OPERATORS MUST ENSURE THAT THERE ARE NO OBSTRUCTIONS BETWEEN THE DOORS AND THE MATING FRAME, FOR EXAMPLE SEAT BELTS, CLOTHING, ETC. WHEN OPERATING THE LOCKING HANDLE DO NOT APPLY UNDUE FORCE. A SLIGHT DOWNWARD/INWARD PRESSURE ON THE DOORS MAY BE REQUIRED TO EASE THE HANDLE OPERATION.

- G Passenger door.....check closed and locked
- H LH & RH Pilot doors.....check closed and locked
- I Door warning (DOOR OPEN).....check no indication
- J Annunciations / Engine / System Page.....check OK / normal range  
(except oil pressure may be in the yellow range with a warm engine and POWER lever set to Ground Idle (GI))
- K Circuit breakers.....check IN
- L Fuel valve.....check NORMAL
- M COWL FLAP.....OPEN
- N Elevator and Rudder trim.....set T/O and to bold area

- O POWER lever.....Ground Idle (GI)
- P FLAPS.....check function & indicator / set T/O

**NOTE**

For maximum service life minimize heater operation during ground operation.

- Q PITOT/STALL HEAT.....ON, if required
- R EMERGENCY FUEL PUMP switch.....check OFF
- S FADEC.....check AUTO
- T Landing light.....ON, if required
- U Flight controls.....unrestricted free movement, correct sense
- V Engine temperatures.....check within green range

**FADEC test sequence:**

**CAUTION**

IF THERE ARE PROLONGED ENGINE MISFIRES OR THE ENGINE SHUTS DOWN DURING THE TEST, DO NOT ATTEMPT TAKE-OFF. THE ENTIRE TEST PROCEDURE MUST BE PERFORMED WITHOUT ANY FAULTS. TAKE-OFF IS NOT PERMITTED IF ECU A/ B FAIL CAUTIONS REMAIN ACTIVE FOLLOWING RELEASING THE FADEC TEST BUTTON. THIS APPLIES EVEN IF THE ENGINE SEEMS TO RUN NORMALLY AGAIN AFTER COMPLETION OF THE TEST PROCEDURE.

**NOTE**

If the test button is released before the self-test is completed, the FADEC immediately switches to normal mode. While switching from one FADEC to another, it is normal to hear and feel a momentary surge of the engine.

- A FADEC TEST button.....press and hold

**WARNING**

**IF ECU A/B FAIL CAUTIONS REMAIN OFF, DO NOT ATTEMPT TAKE-OFF.**

- B ECU A/B FAIL Cautions / Propeller RPM.....check both active during initial RPM increase
- C ECU A FAIL Caution / RPM.....check active during RPM decrease,  
after governor cycle check inactive at Ground Idle (GI)  
RPM
- D ECU B FAIL Caution / RPM.....check active during RPM decrease,  
after governor cycle check inactive at Ground Idle (GI)  
RPM

- E FADEC TEST button.....RELEASE when test sequence completed
- F FADEC.....Force B
- G Engine.....check running without a change

**CAUTION**

RUNNING THE ENGINE WITH THE FADEC ON FORCE B, OTHER THAN FOR THIS TEST OR IN AN EMERGENCY, IS PROHIBITED. THE ENGINE CONTROL SYSTEM REDUNDANCY IS ONLY GIVEN WITH THE FADEC SET ON AUTO.

**NOTE**

When switching from one FADEC to the other a slight shake of the engine may occur.

- H FADEC.....AUTO

**Available power check:**

- A POWER lever.....MAX for 10 seconds
- B Annunciations.....check OK
- C Instruments.....check within normal range
- D RPM.....stabilizes at 2290 to 2340 RPM

**CAUTION**

THE LOAD INDICATIONS IN THE TABLE BELOW ARE MINIMUM VALUES TO BE INDICATED WITH THE AIRPLANE STATIONARY IN NO WIND CONDITIONS. IF THE ENGINE DOES NOT STABILIZE AT THE TARGET RPM AND THE REQUIRED LOAD INDICATION, TERMINATE FLIGHT PREPARATION.

- E LOAD indication.....stabilizes at 85% to 100%

Altitude [ft]	OAT								
	-35°C -31°F	-20°C -4°F	-10°C 14°F	0°C 32°F	10°C 50°F	20°C 68°F	30°C 86°F	40°C 104°F	50°C 122°F
0	99%						99%	97%	96%
2000							98%	97%	96%
4000							98%	97%	96%
6000							98%	96%	96%
8000							97%	96%	95%

Table 1 - Load Indication

Altitude [ft]	OAT								
	-35°C	-20°C	-10°C	0°C	10°C	20°C	30°C	40°C	50°C
	-31°F	-4°F	14°F	32°F	50°F	68°F	86°F	104°F	122°F
10000	89%					88%	87%	86%	85%

Table 1 - Load Indication

F POWER lever.....Ground Idle (GI)

**NOTE**

With the POWER lever in Ground Idle (GI) the oil pressure may be in the low yellow range. This is acceptable to continue flight preparation.

- G Engine instruments.....check in green range
- H ALTERNATE STATIC SOURCE.....PULL (ON), check altimeter, PUSH (OFF)
- I EMERGENCY FUEL PUMP switch.....ON, note fuel pump sound
- J PITOT/STALL HEAT.....as required
- K Ammeter.....check charging
- L Low Voltage and Alternator Warnings.....check OFF
- M ECU A/B FAIL cautions.....check none present
- N COWL FLAP.....OPEN
- O CIRCULATING AIR.....check off / FRESH air
- P ECS shut-off.....checked pushed in / OPEN
- Q Parking brake.....release

## 04-12 Take-Off

### Normal operation procedure

#### 1 Take-Off

- A POWER lever..... MAX (take-off power apply smoothly, for max. 5 min.)
- B RPM.....check 2340 RPM reached during take-off roll
- C Elevator.....neutral

#### NOTE

In strong crosswinds steering can be augmented by use of the toe brakes. It should be noted, however, that this method increases the take-off roll, and should not generally be used.

- D Rudder.....maintain direction
- E Elevator input for rotation..... $V_r$
- F Airspeed for initial climb..... $V_{50ft}$

Flight Mass	up to 1600 kg (3527 lb)	above 1600 kg (3527 lb) up to 1800 kg (3968 lb)	above 1800 kg (3968 lb)
Airspeed for rotation (Take-off run, $v_R$ ) (Flaps T/O)	59 KIAS	64 KIAS	68 KIAS
Airspeed for initial climb ( $v_{50ft}$ ) (Flaps T/O)	69 KIAS	73 KIAS	79 KIAS

Table 1 - Airspeeds

#### At Positive Rate of Climb:

#### NOTE

To avoid damage and excessive wear of the main landing gear wheels, firmly apply brakes before selecting gear up.

- G Landing gear.....apply brakes, UP, check gear unsafe light off

#### At Safe Altitude:

- H LDG, Taxi, Position Lights.....OFF (as required)
- I EMERGENCY FUEL PUMP switch.....OFF

- J FLAPS.....UP
- K LOAD.....latest after 5 min reduce to 90% (MCP)
- L COWL FLAP.....as required
- M ALTERNATE AIR.....OPEN in rain, snow or visible moisture

## 04-13 Climb

### Normal operation procedure

#### 1 Climb

#### CAUTION

IF THE OIL TEMPERATURE AND/OR COOLANT TEMPERATURE REACHES THE YELLOW RANGE DURING CLIMB, FLIGHT SHOULD BE CONTINUED WITH AN AIRSPEED INCREASED BY 5 KT AND POWER REDUCED BY 10% (REDUCED CLIMB RATE) FOR BETTER ENGINE COOLING.

#### NOTE

Operating in the gearbox cautionary range is permitted. However, prolonged operation is not recommended.

A	Landing gear.....	check UP
B	FLAPS.....	check UP
C	Landing light.....	check OFF / as required
D	EMERGENCY FUEL PUMP switch.....	check OFF
E	Airspeed, best rate of climb.....	94 KIAS
F	POWER lever.....	max. 90% (max. 2300 RPM)
G	Annunciations / Engine / System Page.....	monitor
H	COWL FLAP.....	as required



## 04-14 Climb Autopilot

### Normal operation procedure

#### 1 Autopilot Operation During Climb

#### NOTE

The NOSE UP and NOSE DN buttons on the mode controller on the MFD are referenced to airplane movement. The NOSE UP button will increase the reference pitch attitude, increase the reference vertical speed and decrease the reference airspeed. Likewise, the NOSE DN button will decrease the reference pitch attitude, decrease the reference vertical speed, and increase the reference airspeed.

#### Vertical Speed (VS)

- A Altitude preselect (ALT).....set to desired altitude
- B Mode controller.....select VS on mode controller
- C Vertical speed reference.....adjust using NOSE UP  
and NOSE DN buttons  
selected vertical speed is shown on PFD
- D White ALT (altitude preselect armed).....note on PFD
- E Green ALT.....verify upon altitude capture

#### NOTE

If the altitude preselect is not changed before selecting VS, the autopilot may re-capture the current altitude immediately after entering VS mode. Always ensure that the altitude preselect is adjusted prior to selecting VS.

The vertical speed mode is limited to 1500 ft/min climb and 3000 ft/minute descent. Use engine power to maintain appropriate airplane speed. If the CWS switch is used while in VS mode, the VS reference will change to the vertical speed when the CWS switch is released.

#### Flight Level Change (FLC)

- A Altitude preselect (ALT).....set to desired altitude
- B Mode controller.....select FLC on mode controller
- C Airspeed speed reference.....adjust using NOSE UP  
and NOSE DN buttons  
selected vertical speed is shown on PFD

- D White ALT (altitude preselect armed).....note on PFD
- E Green ALT.....verify upon altitude capture

**NOTE**

If the altitude preselect is not changed before selecting FLC, the autopilot may re-capture the current altitude immediately after entering FLC mode. Always ensure that the altitude preselect is adjusted prior to selecting FLC.

If the airspeed reference cannot be maintained without deviating away from the selected altitude, the system will maintain level flight until the power or reference is changed to allow climbing or descending towards the selected altitude.

The FLC mode is limited to airspeeds between 85 KIAS and 185 KIAS. Use engine power to maintain appropriate vertical speed. If the CWS switch is used while in FLC mode, the airspeed reference will change to the airspeed when the CWS switch is released.

**To Capture a Selected Altitude**

- A Altimeter setting.....adjust to appropriate value
- B Altitude preselect (ALT).....set to desired altitude
- C Vertical mode and reference.....select on mode controller
- D White ALT (altitude preselect armed).....note on PFD
- E Green ALT.....verify upon altitude capture

**NOTE**

In ALT mode, the autopilot will maintain the reference altitude shown in the autopilot window of the PFD regardless of the altitude in the altitude preselect window or the altimeter's barometric pressure setting. If the altimeter setting is changed, the autopilot will climb or descend to maintain the reference altitude.

**Navigation Capture and Track**

- A Navigation source.....select VOR or GPS using CDI button on PFD
- B Course bearing pointer (CRS).....set using course knob
- C Intercept heading.....establish in HDG or ROL mode (if required)
- D Mode controller.....select NAV on mode controller
- E Green or white VOR or GPS annunciation.....note on PFD
- F Vertical mode and reference.....select on mode controller

**NOTE**

If the Course Deviation Indicator (CDI) is greater than one dot from center, the autopilot will arm the NAV mode and indicate VOR or GPS in white on the PFD. The pilot must ensure that the current heading will result in a capture of the selected course. If the CDI is one dot or less from center, the autopilot will enter the capture mode when the NAV button is pressed and annunciate VOR or GPS in green on the PFD.

## 04-15 Cruise

### Normal operation procedure

#### 1 Cruise

#### CAUTION

WHEN OPERATING THE FUEL TRANSFER PUMP, MAKE SURE NOT TO EXCEED THE FUEL IMBALANCE LIMITATIONS GIVEN IN [02-14 - FUEL - DESCRIPTION](#).

#### NOTE

The recommended cruise power setting is 75%.

- A POWER lever.....up to 90% or maximum 2300 RPM
- B Trim.....as required
- C Annunciators / Engine / System Page.....monitor
- D COWL FLAP.....as required
- E FUEL TRANS. switch.....repeat as required

## 04-16 Cruise Autopilot

### Normal operation procedure

## 1 Autopilot Operation During Cruise

### NOTE

The NOSE UP and NOSE DN buttons on the mode controller on the MFD are referenced to airplane movement. The NOSE UP button will increase the reference pitch attitude, increase the reference vertical speed and decrease the reference airspeed. Likewise, the NOSE DN button will decrease the reference pitch attitude, decrease the reference vertical speed, and increase the reference airspeed.

### Vertical Speed (VS)

- |   |   |   |
|---|---|---|
| A | Altitude preselect (ALT).....             | set to desired altitude                     |
| B | Mode controller.....                      | select VS on mode controller                |
| C | Vertical speed reference.....             | adjust using NOSE UP<br>and NOSE DN buttons |
| D | White ALT (altitude preselect armed)..... | note on PFD                                 |
| E | Green ALT.....                            | verify upon altitude capture                |

### NOTE

If the altitude preselect is not changed before selecting VS, the autopilot may re-capture the current altitude immediately after entering VS mode. Always ensure that the altitude preselect is adjusted prior to selecting VS.

The vertical speed mode is limited to 1500 ft/min climb and 3000 ft/minute descent. Use engine power to maintain appropriate airplane speed. If the CWS switch is used while in VS mode, the VS reference will change to the vertical speed when the CWS switch is released.

### Flight Level Change (FLC)

- |   |   |   |
|---|---|---|
| A | Altitude preselect (ALT).....             | set to desired altitude                     |
| B | Mode controller.....                      | select FLC on mode controller               |
| C | Airspeed speed reference.....             | adjust using NOSE UP<br>and NOSE DN buttons |
| D | White ALT (altitude preselect armed)..... | note on PFD                                 |
| E | Green ALT.....                            | verify upon altitude capture                |

**NOTE**

If the altitude preselect is not changed before selecting FLC, the autopilot may re-capture the current altitude immediately after entering FLC mode. Always ensure that the altitude preselect is adjusted prior to selecting FLC.

If the airspeed reference cannot be maintained without deviating away from the selected altitude, the system will maintain level flight until the power or reference is changed to allow climbing or descending towards the selected altitude.

The FLC mode is limited to airspeeds between 85 KIAS and 185 KIAS. Use engine power to maintain appropriate vertical speed. If the CWS switch is used while in FLC mode, the airspeed reference will change to the airspeed when the CWS switch is released.

**To Capture a Selected Altitude**

- A Altimeter setting.....adjust to appropriate value
- B Altitude preselect (ALT).....set to desired altitude
- C Vertical mode and reference.....select on mode controller
- D White ALT (altitude preselect armed).....note on PFD
- E Green ALT.....verify upon altitude capture

**NOTE**

In ALT mode, the autopilot will maintain the reference altitude shown in the autopilot window of the PFD regardless of the altitude in the altitude preselect window or the altimeter's barometric pressure setting. If the altimeter setting is changed, the autopilot will climb or descend to maintain the reference altitude.

**Altitude Hold**

To maintain a selected altitude:

- A Altimeter setting.....adjust to appropriate value
- B Reaching desired altitude.....select ALT on mode controller
- C Green ALT.....verify on PFD

**Navigation Capture and Track**

- A Navigation source.....select VOR or GPS using CDI button on PFD

- B Course bearing pointer (CRS).....set using course knob
- C Intercept heading.....establish in HDG or ROL mode  
(if required)
- D Mode controller.....select NAV on mode controller
- E Green or white VOR or GPS annunciation.....note on PFD
- F Vertical mode and reference.....select on mode controller

**NOTE**

If the Course Deviation Indicator (CDI) is greater than one dot from center, the autopilot will arm the NAV mode and indicate VOR or GPS in white on the PFD. The pilot must ensure that the current heading will result in a capture of the selected course. If the CDI is one dot or less from center, the autopilot will enter the capture mode when the NAV button is pressed and annunciate VOR or GPS in green on the PFD.

## 04-17 Fuel Transfer

### Normal operation procedure

#### 1 Fuel Transfer

#### CAUTION

DURING NORMAL OPERATION FUEL IS TAKEN FROM THE MAIN TANK ONLY. THEREFORE FUEL MUST BE TRANSFERRED FROM THE AUXILIARY TANK TO THE MAIN TANK BY ACTIVATING THE FUEL TRANSFER PUMP. THE TRANSFER RATE IS APPROXIMATELY 60 US GAL/H (227 LITER/H).

- A FUEL TRANS. switch.....ON
- The transfer pump turns off automatically to avoid overfilling the main tank. The switch remains in its position. If the pump is not turned off, it will continue pumping each time the fuel level in the main tank drops, but only as long as there is fuel in the auxiliary tank. The fuel transfer status light is illuminated only while the pump is running.
- B FUEL TRANS. switch.....OFF, if required



# 04-18 Descent

## Normal operation procedure

### 1 Descent

- A POWER lever.....as required (at or above flight idle, FI)
- B Airspeed.....as required
- C Trim.....as required
- D PEDs.....OFF, for low visibilty approach

#### NOTE

Definition of the switched-off status for PEDs:

Many PEDs are not completely disconnected from the internal power source when switched off. The switching function may leave some remaining functionality e.g. data storage, timer, clock, etc.

These devices can be considered switched off when in the deactivated status. The same applies to devices having no transmitting capability and are operated by coin cells without further deactivation capability, e.g. wrist watches.

- E Annunciations / Engine/ System Page.....monitor
- F COWL FLAP.....as required

## 04-19 Descent Autopilot

### Normal operation procedure

## 1 Autopilot Operation During Descent

### NOTE

The NOSE UP and NOSE DN buttons on the mode controller on the MFD are referenced to airplane movement. The NOSE UP button will increase the reference pitch attitude, increase the reference vertical speed and decrease the reference airspeed. Likewise, the NOSE DN button will decrease the reference pitch attitude, decrease the reference vertical speed, and increase the reference airspeed.

### Vertical Speed (VS)

- |   |   |   |
|---|---|---|
| A | Altitude preselect (ALT).....             | set to desired altitude                     |
| B | Mode controller.....                      | select VS on mode controller                |
| C | Vertical speed reference.....             | adjust using NOSE UP<br>and NOSE DN buttons |
| D | White ALT (altitude preselect armed)..... | note on PFD                                 |
| E | Green ALT.....                            | verify upon altitude capture                |

### NOTE

If the altitude preselect is not changed before selecting VS, the autopilot may recapture the current altitude immediately after entering VS mode. Always ensure that the altitude preselect is adjusted prior to selecting VS.

The vertical speed mode is limited to 1500 ft/min climb and 3000 ft/minute descent. Use engine power to maintain appropriate airplane speed. If the CWS switch is used while in VS mode, the VS reference will change to the vertical speed when the CWS switch is released.

### Flight Level Change (FLC)

- |   |   |   |
|---|---|---|
| A | Altitude preselect (ALT).....             | set to desired altitude                     |
| B | Mode controller.....                      | select FLC on mode controller               |
| C | Airspeed speed reference.....             | adjust using NOSE UP<br>and NOSE DN buttons |
| D | White ALT (altitude preselect armed)..... | note on PFD                                 |
| E | Green ALT.....                            | verify upon altitude capture                |

## NOTE

If the altitude preselect is not changed before selecting FLC, the autopilot may recapture the current altitude immediately after entering FLC mode. Always ensure that the altitude preselect is adjusted prior to selecting FLC.

If the airspeed reference cannot be maintained without deviating away from the selected altitude, the system will maintain level flight until the power or reference is changed to allow climbing or descending towards the selected altitude.

The FLC mode is limited to airspeeds between 85 KIAS and 185 KIAS. Use engine power to maintain appropriate vertical speed. If the CWS switch is used while in FLC mode, the airspeed reference will change to the airspeed when the CWS switch is released.

## To Capture a Selected Altitude

- A Altimeter setting.....adjust to appropriate value
- B Altitude preselect (ALT).....set to desired altitude
- C Vertical mode and reference.....select on mode controller
- D White ALT (altitude preselect armed).....note on PFD
- E Green ALT.....verify upon altitude capture

## NOTE

In ALT mode, the autopilot will maintain the reference altitude shown in the autopilot window of the PFD regardless of the altitude in the altitude preselect window or the altimeter's barometric pressure setting. If the altimeter setting is changed, the autopilot will climb or descend to maintain the reference altitude.

## Navigation Capture and Track

- A Navigation source.....select VOR or GPS using  
CDI button on PFD
- B Course bearing pointer (CRS).....set using course knob
- C Intercept heading.....establish in HDG or ROL mode  
(if required)
- D Mode controller.....select NAV on mode controller
- E Green or white VOR or GPS annunciation.....note on PFD
- F Vertical mode and reference.....select on mode controller

**NOTE**

If the Course Deviation Indicator (CDI) offset is greater than one dot from center, the autopilot will arm the NAV mode and indicate VOR or GPS in white on the PFD. The pilot must ensure that the current heading will result in a capture of the selected course. If the CDI is one dot or less from center, the autopilot will enter the capture mode when the NAV button is pressed and annunciate VOR or GPS in green on the PFD.

## 04-20 Approach and Landing

### Normal operation procedure

## 1 Approach and Landing

### CAUTION

FOR LANDING THE ADJUSTABLE BACKRESTS MUST BE FIXED IN THE UPRIGHT POSITION.

### NOTE

If LOI annunciation is displayed and GPS based navigation is aborted while on the final approach segment, the missed approach procedure must be executed.

- A Adjustable backrests.....adjust to the upright position described by a placard on the roll-over bar and verify proper fixation
- B Safety harnesses.....check fastened and tightened
- C Sun visors (if installed).....locked in fully upward position
- D PFD/MFD control unit (keypad) (if installed).....stowed
- E Controls.....no interference by foreign objects
- F Landing , Taxi, Position, Strobe Lights (ACL).....as required
- G EMERGENCY FUEL PUMP switch.....ON
- H FUEL valve.....NORMAL
- I Gear warning horn.....check function
- J Landing gear.....DOWN, check 3 green
- K Parking brake.....check released
- L FLAPS.....as required
- M Trim.....as required, directional trim neutral

### CAUTION

IN CONDITIONS SUCH AS (E.G.) STRONG WIND, DANGER OF WIND SHEAR OR TURBULENCE A HIGHER APPROACH SPEED SHOULD BE SELECTED.

### NOTE

Higher approach speeds result in a significantly longer landing distance during flare.

- N Final approach speed.....V<sub>REF</sub>
- O POWER lever.....at or above Flight Idle (FI) until touchdown

<b>Flight Mass</b>	<b>up to 1600 kg (3527 lb)</b>	<b>above 1600 kg (3527 lb) up to 1800 kg (3968 lb)</b>	<b>above 1800 kg (3968 lb)</b>
V <sub>REF</sub> - Flaps UP	84 KIAS	90 KIAS	94 KIAS
V <sub>REF</sub> - Flaps T/O	77 KIAS	79 KIAS	85 KIAS
V <sub>REF</sub> - Flaps LDG	73 KIAS	75 KIAS	77 KIAS

**Table 1 - Airspeeds**

## 04-21 Approach and Landing Autopilot

### Normal operation procedure

## 1 Autopilot Operation During Approach and Landing

### VOR

- A Navigation source.....select VOR using CDI button on PFD
- B Course bearing pointer (CRS).....set using course knob
- C Intercept heading.....establish in HDG or ROL mode (if required)
- D Mode controller.....select APR on mode controller
- E Green or white VAPP annunciation.....note on PFD
- F Vertical mode and reference.....select on mode controller

### NOTE

If the Course Deviation Indicator (CDI) is greater than one dot from center, the autopilot will arm the VAPP mode and indicate VAPP in white on the PFD. The pilot must ensure that the current heading will result in a capture of the selected course. If the CDI is one dot or less from center, the autopilot will enter the capture mode when the VAPP button is pressed and annunciate VAPP in green on the PFD.

### ILS

- A Navigation source.....select LOC using CDI button on PFD
- B Course bearing pointer (CRS).....set using course knob
- C Intercept heading.....establish in HDG or ROL mode (if required)
- D Mode controller.....select APR on mode controller
- E Green or white LOC and GS annunciation.....note on PFD
- F Vertical mode and reference.....select on mode controller

## NOTE

When the selected navigation source is a valid ILS, glideslope coupling is automatically armed when tracking the localizer. The glideslope cannot be captured until the localizer is captured. The autopilot can capture the glideslope from above or below the glideslope.

## GPS

- A Navigation source.....select GPS using CDI button on PFD
- B Approach.....load in FMS and ACTIVATE
- C Intercept heading.....establish in HDG or ROL mode (if required)
- D Mode controller.....select APR on mode controller
- E Green or white GPS annunciation.....note on PFD
- F Vertical mode and reference.....select on mode controller

## Back Course (BC)

- A Navigation source.....select LOC using CDI button on PFD
- B Course bearing pointer (CRS).....set to ILS front course using course knob
- C Intercept heading.....establish in HDG or ROL mode (if required)
- D Mode controller.....select NAV on mode controller
- E Green or white BC annunciation.....note on PFD

## NOTE

The course pointer must be at least 115° from the current magnetic heading before BC will be annunciated in the lateral mode field. Until that point, LOC will be annunciated.

Selecting NAV mode for back course approaches inhibits the glideslope from coupling.

- F Vertical mode and reference.....select on mode controller



**04-22 Go Around**  
**Normal operation procedure**

**1 Go-Around**

- A POWER lever.....MAX (max. 5 min)
- B FLAPS.....T/O
- C Airspeed.....77 KIAS up to 1600 kg (3527 lb)  
79 KIAS above 1600 kg (3527 lb)  
up to 1800 kg (3968 lb)  
85 KIAS above 1800 kg (3968 lb)
- D COWL FLAP.....OPEN, as required

***When a positive rate of climb is established:***

- E Landing gear.....UP
- F FLAPS.....retract, position UP

***When a safe climb is established:***

- G EMERGENCY FUEL PUMP switch.....OFF

# 04-23 Go Around Autopilot Normal operation procedure

## 1 Autopilot Operation During Go Around

- A Control Stick.....grasp firmly
- B GA button.....push - verify GA/GA on PFD  
in lateral and vertical mode fields

### NOTE

After the GA button is pressed, the autopilot disconnects and the flight director indicates a 6° pitch up attitude.

- C Balked landing.....execute
- D Missed approach procedure.....execute (as applicable)
- E Altitude preseselect (ALT).....set to appropriate altitude

### ***At an appropriate safe altitude:***

- F Autopilot mode controller.....select appropriate lateral  
and vertical mode on controller
- G Autopilot.....re-engage if desired  
and vertical mode on controller

### NOTE

If the missed approach procedure requires tracking the localizer outbound from the airport, use NAV mode to prevent inadvertent coupling to glideslope.

**04-24 After Landing**  
**Post-operation procedure**

**1 After Landing**

- A POWER lever.....Ground Idle (GI)
- B Brakes.....as required
- C ALTERNATE AIR.....CLOSED
- D Lights.....as required
- E Avionics.....as required
- F EMERGENCY FUEL PUMP switch.....OFF
- G PITOT/STALL HEAT.....OFF
- H FLAPS.....UP

## 04-25 Engine Shut Down

### Post-operation procedure

#### 1 Engine Shut-Down

#### CAUTION

DO NOT SHUT DOWN AN ENGINE WITH THE FUEL VALVE. THE HIGH PRESSURE FUEL PUMP CAN BE DAMAGED OTHERWISE.

A	Parking brake.....	set
B	POWER lever.....	Ground Idle (GI) at least 2 minutes
C	FLAPS.....	check UP
D	Engine/System Page.....	check
E	COWL FLAP.....	CLOSED
F	AVIONIC MASTER.....	OFF
G	Electrical consumers.....	OFF
H	ENGINE MASTER.....	OFF
I	Landing, Taxi, Position, Strobe Lights (ACL).....	OFF
J	ALTERNATOR 1 and 2.....	CHECK ON
K	ELECT. MASTER.....	OFF

**04-26 Exit Airplane**  
**Post-operation procedure**

**1 Exit Airplane**

A Exit the airplane to the aft on designated areas on the wing LH or RH.

## 04-27 Post Flight Inspection

### Post-operation procedure

#### 1 Post Flight Inspection

- A Record any problem found in flight and during the post-flight check in the log book.
- B Park the airplane.
- C If necessary, moor the airplane.

**04-28 Parking**  
**Post-operation procedure**

**1 Parking**

- A Parking brake.....release, use chocks
- B Map light.....check OFF
- C Airplane.....moor, if unsupervised for extended period

**WARNING**

**THE PITOT PROBE BECOMES VERY HOT DURING OPERATION.  
BE CAREFULL TO AVOID BURNS. THIS CAN CAUSE INJURIES  
TO PERSONS.**

- D Pitot static probe.....cover
- E Emergency exit window.....install pin

**04-29 Flight in Rain**  
**Normal operation procedure**

**1 Flight in Rain, Snow or Visible Moisture**

**CAUTION**

DURING OPERATION ON GROUND ALTERNATE AIR MUST BE CLOSED.

**NOTE**

Performance deteriorates in rain; this applies particularly to the take-off distance and to the maximum horizontal speed. The effect on the flight characteristics is minimal. Flight through very heavy rain should be avoided because of the associated visibility problems during VFR flights.

A ALTERNATE AIR .....OPEN



## 04-30 Refueling

### Description

## 1 Refueling

### CAUTION

BEFORE REFUELING, THE AIRPLANE MUST BE CONNECTED TO ELECTRICAL GROUND. GROUNDING POINTS: UNPAINTED AREAS ON STEPS, LEFT AND RIGHT.

ONLY APPROVED FUEL ADDITIVES NOT EXCEEDING THE APPROVED CONCENTRATIONS MAY BE USED; REFER TO [02-14 - FUEL - DESCRIPTION](#). THE INSTRUCTIONS OF THE FUEL ADDITIVE SUPPLIER MUST BE FOLLOWED. FAILURE TO EXACTLY FOLLOW THE FUEL ADDITIVE MIXING PROCEDURES DURING REFUELING CAN RESULT IN INCORRECT FUEL ADDITIVE CONCENTRATIONS, FUEL SYSTEM CONTAMINATION AND POSSIBLE ENGINE STOPPAGE.

Fuel additives may have been already mixed into the fuel when stored. In this case make sure that the brand is approved and the concentration does not exceed the approved values.

Anti-microbial life fuel additives may be manually batch-blended into the fuel tanks. In this case introduce the additive while filling the tank after approximately the half tank is filled.

Anti-icing fuel additives should not be batch-blended into the fuel tank. The fuel additive should be injected into a stream of fuel.

Record the brand and amount of fuel additives in the airplane log every time fuel additives are added.

Typical Dosing Quantities:

#### 1 BIOBOR JF

Fuel Quantity				Fuel Additive *, **			
				BIOBOR JF		BIOBOR JF	
				135 ppm		270 ppm	
Liter	US gal	kg	lb	ml	oz	ml	oz
50	13.2	40.2	88.68	5.2	0.18	10.4	0.35
100	26.4	80.4	177.37	10.4	0.35	20.9	0.71
150	39.6	120.6	266.05	15.6	0.53	31.3	1.06

\* Calculation according to SB No. 982, 'Instructions for use of BIOBOR JF'

Table 1 - BIOBOR JF

## 2 PRIST Hi-Flash

Fuel Quantity				Fuel Additive *, ** PRIST Hi-Flash (1500 ppm)	
Liter	US gal	kg	lb	ml	oz
50	13.2	40.2	88.68	58.9	1.99
100	26.4	80.4	177.37	117.9	3.99
150	39.6	120.6	266.05	176.8	5.98
* Densities used for calculation: Fuel: 0.804 kg/l, PRIST Hi-Flash: 1.05 kg/l ** Do not batch blend					

Table 2 - PRIST Hi-Flash

## 04-31 Flight at High Altitude

### Description

#### 1 Flight at High Altitude

At high altitudes the provision of oxygen for the occupants is necessary. Legal requirements for the provision of oxygen should be adhered to.

# 05 PERFORMANCE

# PERFORMANCE GENERAL

## 05-01 Performance data

### Description

#### 1 Introduction

The performance tables and diagrams on the following pages are presented so that, on the one hand, you can see what performance you can expect from your airplane, while on the other hand they allow comprehensive and sufficiently accurate flight planning. The values in the tables and the diagrams were obtained in the framework of the flight trials using an airplane and power-plant in normal condition, and corrected to the conditions of the International Standard Atmosphere (ISA = 15 °C / 59 °F and 1013.25 hPa / 29.92 inHg at sea level).

The performance diagrams and tables do not take into account variations in pilot experience or a poorly maintained airplane. The performances given can be attained if the procedures quoted in this manual are applied, and the airplane has been maintained in accordance with manufacturers information.

## 05-02 Use Of Performance Tables and Diagrams

### Description

#### 1 Use of the Performance Tables and Diagrams

In order to illustrate the influence of a number of different variables, the performance data is reproduced in the form of tables or diagrams. These contain sufficiently detailed information so that conservative values can be selected and used for the determination of adequate performance data for the planned flight.

For a conversion of units see [01-05 - Conversion Factors - Description](#).

For temperatures, altitudes and weights between those provided, use a linear interpolation between the neighboring values.

For weights below 1600 kg (3527 lb), use data for the lowest weight.

For operation in outside air temperature lower than provided in these tables, use data for lowest temperature shown.

For operation in outside air temperature higher than provided in these tables, use extreme caution.

## 05-03 Airspeed Calibration

### Description

#### 1 Airspeed Calibration

##### 1 Airspeed Calibration - Flaps TO / LDG

Indicated Airspeed [KIAS]	Calibrated Airspeed [KCAS]
60	59
65	63
70	68
75	73
80	78
85	83
90	88
95	93
100	98
105	103
110	108
115	112
120	117
125	122
130	127
133	130

**Table 1 - Airspeed Calibration - Flaps TO / LDG**



**2 Airspeed Calibration - Flaps UP**

Indicated Airspeed [KIAS]	Calibrated Airspeed [KCAS]
70	70
75	74
80	79
85	84
90	88
95	93
100	98
105	103
110	108
115	113
120	118
125	123
130	128
135	133
140	138
145	143
150	148
155	153
160	158
165	163
170	168
175	173
180	178
185	183
190	188

**Table 2 - Airspeed Calibration - Flaps UP**

# 05-04 International Standard Atmosphere

## Description

### 1 International Standard Atmosphere

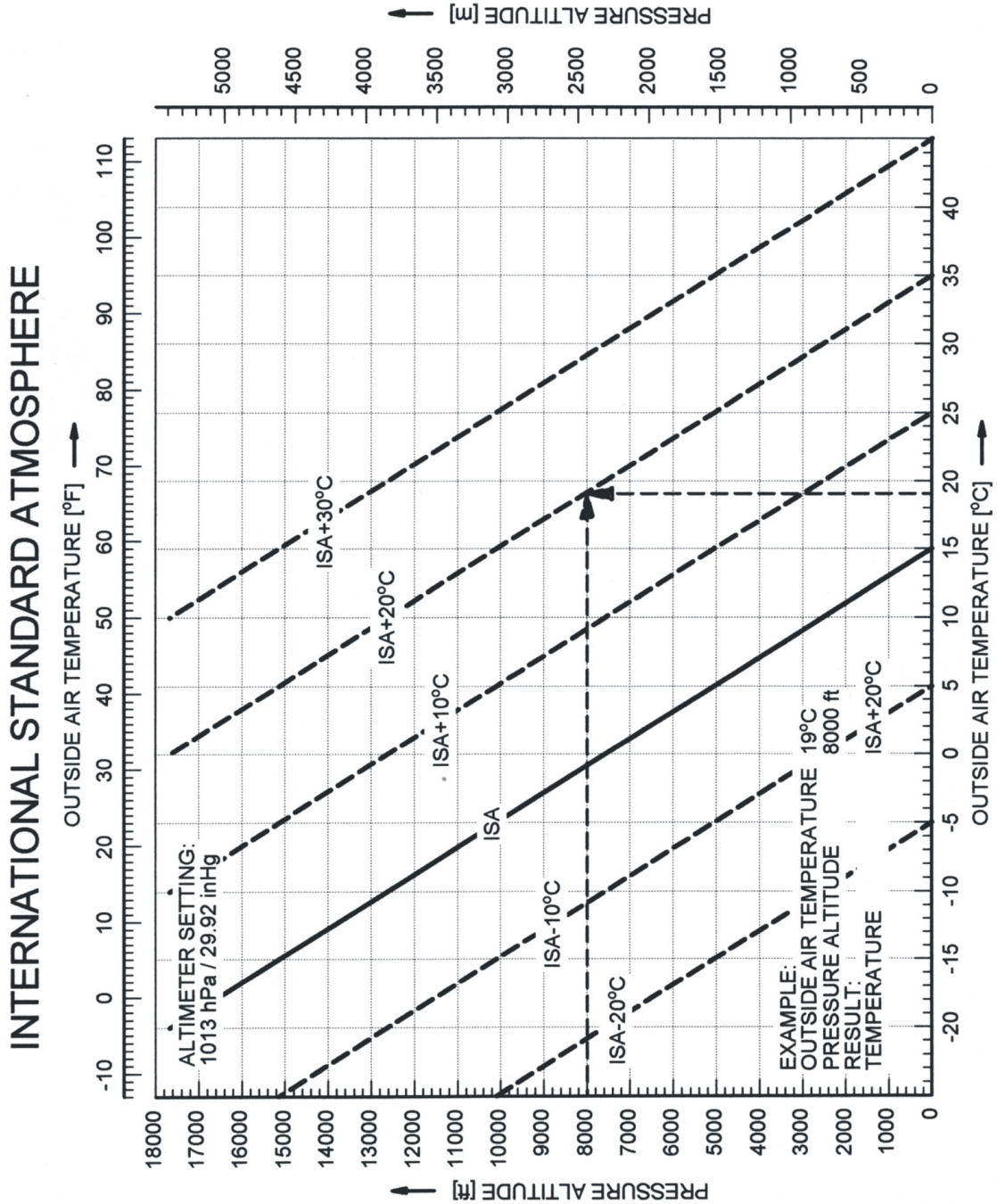

Figure 1 - International Standard Atmosphere

## 05-05 Stalling Speeds

### Description

#### 1 Stalling Speeds

Stalling Speed at Various Flight Masses.

Airspeeds, most forward CG, Flight Idle (FI):

1600 kg (3527 lb)		Bank Angle							
		0°		30°		45°		60°	
Gear	Flaps	KIAS	KCAS	KIAS	KCAS	KIAS	KCAS	KIAS	KCAS
UP	UP	63	63	68	68	76	75	91	89
DOWN	TO	57	56	62	60	68	67	81	79
DOWN	LDG	52	51	56	55	62	61	74	72

Table 1 - Stalling Speeds - 1600 kg (3527 lb)

1800 kg (3968 lb)		Bank Angle							
		0°		30°		45°		60°	
Gear	Flaps	KIAS	KCAS	KIAS	KCAS	KIAS	KCAS	KIAS	KCAS
UP	UP	66	66	71	71	80	78	95	93
DOWN	TO	60	59	65	63	72	70	85	83
DOWN	LDG	55	54	64	62	71	69	84	82

Table 2 - Stalling Speeds - 1800 kg (3968 lb)

1999 kg (4407 lb)		Bank Angle							
		0°		30°		45°		60°	
Gear	Flaps	KIAS	KCAS	KIAS	KCAS	KIAS	KCAS	KIAS	KCAS
UP	UP	72	71	77	76	86	84	102	100
DOWN	TO	66	64	70	69	78	76	93	91
DOWN	LDG	59	58	64	62	71	69	84	82

Table 3 - Stalling Speeds - 1999 kg (4407 lb)

#### NOTE

KIAS values may not be accurate at stall.

## 05-06 Wind Components Description

### 1 Wind Components

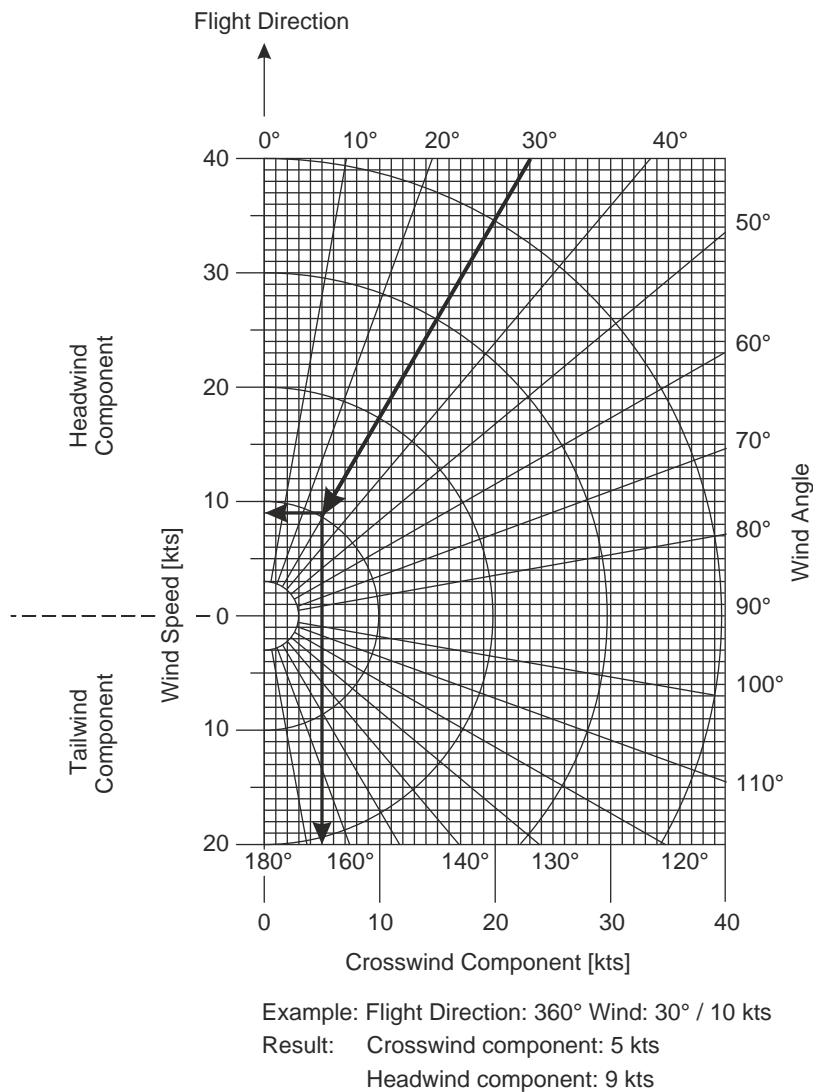

**Figure 2 - Wind Components Diagram**

Max. demonstrated crosswind component: 22 kts

# TAKE OFF DISTANCE

## 05-07 Take-Off Distance

### Description

#### 1 Take-Off Distance

##### Conditions

Power lever	MAX
Flaps	T/O
Runway	dry, paved, level
Nose wheel lift-off	$V_R$
Airspeed for initial climb	$V_{50ft}$

The following factors are to be applied to the computed take-off distance for the noted condition:

Headwind	Decrease by 4% for each 5 kt (2.6 m/s) headwind.
Tailwind	Increase by 20% for each 5 kt (2.6 m/s) tailwind.
Grass runway, dry, 5 cm (2 in) long	Increase the ground roll by 10%.
Grass runway, dry, 5 cm (2 in) to 10 cm (3.9 in) long	Increase the ground roll by 15%.
Grass runway, dry, 25 cm (9.8 in) long	Increase the ground roll by 25%.
Grass runway, longer than 25 cm (9.8 in)	A take-off should not be attempt.
Grass runway, wet	Increase the dry grass runway distance calculation by 10%.
Soft ground	Increase the ground roll by 45% (in addition to the grass runway distance calculation, if applicable).
Uphill slope	Increase the ground roll by 14% for each 1% (1 m per 100 m or 1 ft per 100 ft) slope.

If brakes are not held while applying power, distances apply from where full power setting is reached.

#### WARNING

**FOR A SAFE TAKE-OFF THE AVAILABLE RUNWAY LENGTH MUST BE AT LEAST EQUAL TO THE TAKE-OFF DISTANCE OVER A 50 FT (15 M) OBSTACLE.**

#### WARNING

**POOR MAINTENANCE CONDITION OF THE AIRPLANE, DEVIATION FROM THE GIVEN PROCEDURES, UNEVEN RUNWAY, AS WELL AS UNFAVORABLE EXTERNAL FACTORS (RAIN, UNFAVORABLE WIND CONDITIONS, INCLUDING CROSS-WIND) WILL INCREASE THE TAKE-OFF DISTANCE.**

**CAUTION**

THE FACTORS IN THE ABOVE CORRECTIONS ARE TYPICAL VALUES. ON WET GROUND OR WET SOFT GRASS COVERED RUNWAYS THE TAKE-OFF ROLL MAY BECOME SIGNIFICANTLY LONGER THAN STATED ABOVE. IN ANY CASE THE PILOT MUST ALLOW FOR THE CONDITION OF THE RUNWAY TO ENSURE A SAFE TAKE-OFF.

THE ABOVE CORRECTIONS FOR RUNWAY SLOPE SHOULD BE USED WITH CAUTION SINCE PUBLISHED RUNWAY SLOPE DATA IS USUALLY THE NET SLOPE FROM ONE END OF THE RUNWAY TO THE OTHER. RUNWAYS MAY HAVE POSITIONS AT THEIR LENGTH AT GREATER OR LESSER SLOPES, LENGTHENING (OR SHORTENING) THE TAKE-OFF ROLL ESTIMATED WITH THESE TABLES.

**NOTE**

The effect of 50% of the headwind component and 150% of the tailwind component is already incorporated in the head and tailwind factors.

**05-08 Take-Off Distance 1999 kg**  
**Description**



Take-Off Distance - Normal Procedure - 1999 kg / 4407 lb - [SI-units]								
<b>Weight:</b>	1999 kg / 4407 lb			<b>Flaps:</b>	T/O			
<b>V<sub>R</sub>:</b>	68 KIAS			<b>Power:</b>	MAX			
<b>V<sub>50ft</sub>:</b>	79 KIAS			<b>Runway:</b>	dry, paved, level			
Distances are given in meter [m]								
Press. Alt. [ft] / [m]		Outside Air Temperature - [°C] / [°F]						ISA
		0 / 32	10 / 50	20 / 68	30 / 86	40 / 104	50 / 122	
<b>SL</b>	Ground Roll	380	400	420	450	510	580	407
	15 m / 50 ft	680	720	760	800	910	1040	734
<b>1000</b> 305	Ground Roll	400	420	450	480	550	620	428
	15 m / 50 ft	720	760	810	850	990	1130	771
<b>2000</b> 610	Ground Roll	420	450	480	520	590	670	452
	15 m / 50 ft	760	810	860	920	1070	1220	810
<b>3000</b> 914	Ground Roll	450	480	510	560	640	730	475
	15 m / 50 ft	810	860	910	1000	1160	1330	851
<b>4000</b> 1219	Ground Roll	480	510	540	600	690	790	500
	15 m / 50 ft	860	920	970	1090	1260	1440	896
<b>5000</b> 1524	Ground Roll	520	550	580	660	760	---	527
	15 m / 50 ft	920	980	1040	1190	1380	---	948
<b>6000</b> 1829	Ground Roll	560	590	630	730	830	---	566
	15 m / 50 ft	1000	1070	1140	1310	1520	---	1018
<b>7000</b> 2134	Ground Roll	610	650	700	800	910	---	606
	15 m / 50 ft	1090	1170	1260	1460	1690	---	1093
<b>8000</b> 2438	Ground Roll	660	700	770	880	1010	---	651
	15 m / 50 ft	1190	1270	1390	1620	1870	---	1176
<b>9000</b> 2743	Ground Roll	760	810	890	1030	1170	---	737
	15 m / 50 ft	1400	1500	1670	1950	2260	---	1361
<b>10000</b> 3048	Ground Roll	870	930	1050	1200	---	---	840
	15 m / 50 ft	1660	1790	2040	2380	---	---	1598

Take-Off Distance - Normal Procedure - 1999 kg / 4407 lb - [imperial units]								
<b>Weight:</b>	1999 kg / 4407 lb			<b>Flaps:</b>	T/O			
<b>V<sub>R</sub>:</b>	68 KIAS			<b>Power:</b>	MAX			
<b>V<sub>50ft</sub>:</b>	79 KIAS			<b>Runway:</b>	dry, paved, level			
Distances are given in feet [ft]								
Press. Alt. [ft] / [m]		Outside Air Temperature - [°F] / [°C]						ISA
		30 / -1	50 / 10	70 / 21	90 / 32	110 / 43	130 / 54	
<b>SL</b>	Ground Roll	1250	1300	1400	1500	1650	1900	1336
	15 m / 50 ft	2250	2350	2500	2650	3000	3450	2406
<b>1000</b> 305	Ground Roll	1300	1400	1500	1600	1800	2050	1402
	15 m / 50 ft	2350	2500	2650	2800	3250	3700	2528
<b>2000</b> 610	Ground Roll	1400	1500	1600	1700	1950	2200	1480
	15 m / 50 ft	2500	2650	2850	3050	350	4000	2655
<b>3000</b> 914	Ground Roll	1500	1600	1700	1850	2100	2400	1559
	15 m / 50 ft	2650	2850	3000	3300	3800	4350	2792
<b>4000</b> 1219	Ground Roll	1600	1700	1800	2000	2300	2600	1638
	15 m / 50 ft	2850	3000	3200	3600	4150	4750	2938
<b>5000</b> 1524	Ground Roll	1700	1800	1900	2150	2500	---	1729
	15 m / 50 ft	3050	3250	3450	3900	4550	---	3109
<b>6000</b> 1829	Ground Roll	1850	1950	2100	2400	2750	---	1856
	15 m / 50 ft	3300	3500	3750	4300	5000	---	3338
<b>7000</b> 2134	Ground Roll	2000	2150	2300	2650	3000	---	1989
	15 m / 50 ft	3600	3850	4150	4800	5550	---	3585
<b>8000</b> 2438	Ground Roll	2150	2300	2500	2900	3300	---	2133
	15 m / 50 ft	3900	4200	4600	5350	6150	---	3857
<b>9000</b> 2743	Ground Roll	2500	2650	2950	3400	3850	---	2418
	15 m / 50 ft	4600	4950	5500	6400	7400	---	4463
<b>10000</b> 3048	Ground Roll	2850	3050	3450	3950	---	---	2755
	15 m / 50 ft	5450	5900	6700	7850	---	---	5242

**05-09 Take-Off Distance 1800 kg**  
**Description**

Take-Off Distance - Normal Procedure - 1800 kg / 3968 lb - [SI-units]								
<b>Weight:</b>	1800 kg / 3968 lb			<b>Flaps:</b>	T/O			
<b>V<sub>R</sub>:</b>	64 KIAS			<b>Power:</b>	MAX			
<b>V<sub>50ft</sub>:</b>	73 KIAS			<b>Runway:</b>	dry, paved, level			
Distances are given in meter [m]								
Press. Alt. [ft] / [m]		Outside Air Temperature - [°C] / [°F]						ISA
		0 / 32	10 / 50	20 / 68	30 / 86	40 / 104	50 / 122	
<b>SL</b>	Ground Roll	300	310	330	350	400	460	321
	15 m / 50 ft	510	530	560	600	670	770	544
<b>1000</b> 305	Ground Roll	310	340	360	380	430	490	337
	15 m / 50 ft	540	570	600	630	730	830	571
<b>2000</b> 610	Ground Roll	340	360	380	410	470	530	355
	15 m / 50 ft	570	600	630	680	780	890	599
<b>3000</b> 914	Ground Roll	360	380	400	440	510	570	374
	15 m / 50 ft	600	640	670	740	850	960	629
<b>4000</b> 1219	Ground Roll	380	400	430	480	550	620	393
	15 m / 50 ft	640	670	720	800	920	1040	660
<b>5000</b> 1524	Ground Roll	410	430	460	520	590	---	415
	15 m / 50 ft	680	720	760	860	990	---	697
<b>6000</b> 1829	Ground Roll	440	470	500	570	650	---	445
	15 m / 50 ft	730	780	830	950	1090	---	743
<b>7000</b> 2134	Ground Roll	480	510	550	630	720	---	476
	15 m / 50 ft	790	850	910	1050	1210	---	796
<b>8000</b> 2438	Ground Roll	520	550	600	690	790	---	511
	15 m / 50 ft	860	920	1010	1160	1330	---	856
<b>9000</b> 2743	Ground Roll	590	630	700	800	920	---	577
	15 m / 50 ft	1000	1070	1190	1380	1580	---	977
<b>10000</b> 3048	Ground Roll	680	730	820	940	---	---	655
	15 m / 50 ft	1170	1260	1420	1640	---	---	1129

Take-Off Distance - Normal Procedure - 1800 kg / 3968 lb - [imperial units]								
<b>Weight:</b>	1800 kg / 3968 lb			<b>Flaps:</b>	T/O			
<b>V<sub>R</sub>:</b>	64 KIAS			<b>Power:</b>	MAX			
<b>V<sub>50ft</sub>:</b>	73 KIAS			<b>Runway:</b>	dry, paved, level			
Distances are given in feet [ft]								
Press. Alt. [ft] / [m]		Outside Air Temperature - [°F] / [°C]						ISA
		30 / -1	50 / 10	70 / 21	90 / 32	110 / 43	130 / 54	
<b>SL</b>	Ground Roll	1000	1050	1100	1150	1300	1500	1053
	15 m / 50 ft	1650	1750	1850	1950	2200	2550	1782
<b>1000</b> 305	Ground Roll	1050	1100	1200	1250	1450	1600	1103
	15 m / 50 ft	1750	1850	1950	2100	2400	2700	1874
<b>2000</b> 610	Ground Roll	1100	1200	1250	1350	1550	1750	1165
	15 m / 50 ft	1850	1950	2100	2250	2600	2950	1965
<b>3000</b> 914	Ground Roll	1200	1250	1350	1450	1650	1900	1227
	15 m / 50 ft	2000	2100	2200	2400	2800	3150	2064
<b>4000</b> 1219	Ground Roll	1250	1350	1400	1600	1800	2050	1289
	15 m / 50 ft	2100	2200	2350	2600	3000	3450	2164
<b>5000</b> 1524	Ground Roll	1350	1450	1500	1700	1950	---	1362
	15 m / 50 ft	2250	2400	2500	2850	3250	---	2285
<b>6000</b> 1829	Ground Roll	1450	1550	1650	1900	2150	---	1458
	15 m / 50 ft	2400	2550	2750	3150	3600	---	2437
<b>7000</b> 2134	Ground Roll	1600	1700	1800	2050	2350	---	1561
	15 m / 50 ft	2600	2800	3000	3450	4000	---	2612
<b>8000</b> 2438	Ground Roll	1700	1800	2000	2300	2600	---	1675
	15 m / 50 ft	2850	3050	3300	3800	4400	---	2809
<b>9000</b> 2743	Ground Roll	1950	2100	2300	2650	3000	---	1893
	15 m / 50 ft	3300	3550	3900	4500	5200	---	3204
<b>10000</b> 3048	Ground Roll	2250	2400	2700	3100	---	---	2149
	15 m / 50 ft	3850	4150	4650	5400	---	---	3703

**05-10 Take-Off Distance 1600 kg**  
**Description**

Take-Off Distance - Normal Procedure - 1600 kg / 3527 lb - [SI-units]								
<b>Weight:</b>	1600 kg / 3527 lb			<b>Flaps:</b>	T/O			
<b>V<sub>R</sub>:</b>	59 KIAS			<b>Power:</b>	MAX			
<b>V<sub>50ft</sub>:</b>	69 KIAS			<b>Runway:</b>	dry, paved, level			
Distances are given in meter [m]								
Press. Alt. [ft] / [m]		Outside Air Temperature - [°C] / [°F]						ISA
		0 / 32	10 / 50	20 / 68	30 / 86	40 / 104	50 / 122	
<b>SL</b>	Ground Roll	230	240	260	280	310	350	248
	15 m / 50 ft	390	410	440	460	520	590	420
<b>1000</b> 305	Ground Roll	240	260	280	290	330	380	260
	15 m / 50 ft	410	440	460	490	560	630	440
<b>2000</b> 610	Ground Roll	260	280	290	320	360	410	274
	15 m / 50 ft	440	460	490	520	600	680	462
<b>3000</b> 914	Ground Roll	280	290	310	340	390	440	290
	15 m / 50 ft	460	490	520	560	650	740	484
<b>4000</b> 1219	Ground Roll	300	310	330	370	420	480	304
	15 m / 50 ft	490	520	550	610	700	800	508
<b>5000</b> 1524	Ground Roll	320	340	360	400	460	---	321
	15 m / 50 ft	520	550	590	660	760	---	536
<b>6000</b> 1829	Ground Roll	340	360	390	440	510	---	344
	15 m / 50 ft	560	600	640	730	840	---	571
<b>7000</b> 2134	Ground Roll	370	400	430	490	560	---	369
	15 m / 50 ft	610	650	700	810	920	---	613
<b>8000</b> 2438	Ground Roll	400	430	470	540	610	---	396
	15 m / 50 ft	660	710	770	890	1020	---	656
<b>9000</b> 2743	Ground Roll	460	490	540	630	710	---	448
	15 m / 50 ft	760	820	900	1040	1190	---	744
<b>10000</b> 3048	Ground Roll	530	570	630	730	---	---	507
	15 m / 50 ft	880	950	1070	1230	---	---	854

Take-Off Distance - Normal Procedure - 1600 kg / 3527 lb - [imperial units]								
<b>Weight:</b>	1600 kg / 3527 lb			<b>Flaps:</b>	T/O			
<b>V<sub>R</sub>:</b>	59 KIAS			<b>Power:</b>	MAX			
<b>V<sub>50ft</sub>:</b>	69 KIAS			<b>Runway:</b>	dry, paved, level			
Distances are given in feet [ft]								
Press. Alt. [ft] / [m]		Outside Air Temperature - [°F] / [°C]						ISA
		30 / -1	50 / 10	70 / 21	90 / 32	110 / 43	130 / 54	
<b>SL</b>	Ground Roll	750	800	850	900	1050	1150	812
	15 m / 50 ft	1300	1350	1450	1500	1700	1950	1376
<b>1000</b> 305	Ground Roll	800	850	900	950	1100	1250	853
	15 m / 50 ft	1350	1450	1500	1600	1850	2100	1441
<b>2000</b> 610	Ground Roll	850	900	950	1050	1200	1350	899
	15 m / 50 ft	1450	1550	1600	1750	2000	2250	1513
<b>3000</b> 914	Ground Roll	900	1000	1050	1150	1300	1450	950
	15 m / 50 ft	1550	1600	1700	1850	2150	2450	1586
<b>4000</b> 1219	Ground Roll	1000	1050	1100	1200	1400	1600	997
	15 m / 50 ft	1600	1700	1800	2000	2300	2600	1665
<b>5000</b> 1524	Ground Roll	1050	1100	1200	1350	1500	---	1053
	15 m / 50 ft	1750	1850	1950	2200	2500	---	1757
<b>6000</b> 1829	Ground Roll	1150	1200	1300	1450	1700	---	1128
	15 m / 50 ft	1850	2000	2100	2400	2750	---	1873
<b>7000</b> 2134	Ground Roll	1250	1300	1400	1600	1850	---	1208
	15 m / 50 ft	2000	2150	2300	2650	3050	---	2009
<b>8000</b> 2438	Ground Roll	1350	1400	1550	1800	2000	---	1299
	15 m / 50 ft	2200	2350	2550	2900	3350	---	2151
<b>9000</b> 2743	Ground Roll	1500	1600	1800	2050	2350	---	1469
	15 m / 50 ft	2500	2700	2950	3450	3950	---	2439
<b>10000</b> 3048	Ground Roll	1750	1850	2100	2400	---	---	1663
	15 m / 50 ft	2900	3100	3500	4050	---	---	2801



# CLIMB PERFORMANCE TAKE OFF CLIMB

## 05-11 Climb Performance - Take-Off Climb

### Description

#### 1 Climb Performance - Take-Off Climb

##### Conditions:

Power lever	90% or maximum 2300 RPM
Flaps	T/O
Landing gear	retracted
Airspeed	$v_Y$

The climb performance tables show the rate of climb. The gradient of climb can be calculated using the following formula:

$$\text{Gradient [\%]} = \frac{\text{ROC [fpm]}}{\text{TAS [KTAS]}} \cdot 0.98$$

Figure 1 - Gradient Formula

#### NOTE

Rate of climb at 1999 kg / 4407 lb with a power setting of 100% at MSL and ISA conditions:

- 853 ft/min (4.3 m/s).

## 05-12 Climb Performance - Take-Off Climb 1999 kg

### Description

Take-Off Climb - Flaps T/O - 1999 kg / 4407 lb									
<b>Flaps:</b>	T/O			<b>Power:</b>	90%, max. 2300 RPM				
<b>Airspeed:</b>	79 KIAS			<b>Gear:</b>	retracted				
Press. Alt. [ft] / [m]	Rate of Climb [ft/min]								
	Outside Air Temperature - [°C] / [°F]								ISA
	-20 / -4	-10 / 14	0 / 32	10 / 50	20 / 68	30 / 86	40 / 104	50 / 122	
<b>SL</b>	730	720	710	710	700	690	660	610	704
<b>2000</b> 610	710	710	700	690	680	670	630	570	690
<b>4000</b> 1219	700	690	680	670	660	640	590	530	673
<b>6000</b> 1829	680	670	660	650	640	600	540	---	655
<b>8000</b> 2438	660	650	630	620	610	550	500	---	636
<b>10000</b> 3048	610	600	580	570	540	480	---	---	589
<b>12000</b> 3658	540	530	520	500	450	370	---	---	527
<b>14000</b> 4267	460	440	430	400	340	270	---	---	445
<b>16000</b> 4877	340	320	310	260	200	---	---	---	331
<b>18000</b> 5486	180	170	150	90	20	---	---	---	183
<b>20000</b> 6096	20	0	-40	-100	---	---	---	---	27

## 05-13 Climb Performance - Take-Off Climb 1800 kg

### Description

Take-Off Climb - Flaps T/O - 1800 kg / 3968 lb									
<b>Flaps:</b>	T/O			<b>Power:</b>	90%, max. 2300 RPM				
<b>Airspeed:</b>	79 KIAS			<b>Gear:</b>	retracted				
Press. Alt. [ft] / [m]	Rate of Climb [ft/min]								
	Outside Air Temperature - [°C] / [°F]								ISA
	-20 / -4	-10 / 14	0 / 32	10 / 50	20 / 68	30 / 86	40 / 104	50 / 122	
<b>SL</b>	860	850	850	840	830	830	790	730	836
<b>2000</b> 610	840	840	830	820	810	810	750	690	822
<b>4000</b> 1219	830	820	810	800	790	770	710	650	805
<b>6000</b> 1829	810	800	790	780	770	720	660	---	787
<b>8000</b> 2438	790	780	770	750	740	680	610	---	768
<b>10000</b> 3048	740	720	710	700	660	600	---	---	718
<b>12000</b> 3658	670	650	640	630	560	480	---	---	652
<b>14000</b> 4267	570	560	540	520	450	360	---	---	563
<b>16000</b> 4877	440	430	410	360	290	---	---	---	439
<b>18000</b> 5486	280	260	240	170	100	---	---	---	277
<b>20000</b> 6096	100	80	40	-30	---	---	---	---	107

## 05-14 Climb Performance - Take-Off Climb 1600 kg

### Description

Take-Off Climb - Flaps T/O - 1600 kg / 3527 lb									
<b>Flaps:</b>	<b>T/O</b>			<b>Power:</b>	<b>90%, max. 2300 RPM</b>				
<b>Airspeed:</b>	<b>79 KIAS</b>			<b>Gear:</b>	<b>retracted</b>				
<b>Press. Alt. [ft] / [m]</b>	<b>Rate of Climb [ft/min]</b>								
	<b>Outside Air Temperature - [°C] / [°F]</b>								<b>ISA</b>
	<b>-20 / -4</b>	<b>-10 / 14</b>	<b>0 / 32</b>	<b>10 / 50</b>	<b>20 / 68</b>	<b>30 / 86</b>	<b>40 / 104</b>	<b>50 / 122</b>	
<b>SL</b>	1010	1010	1000	1000	990	980	940	870	992
<b>2000</b> 610	1000	990	990	980	970	960	900	830	978
<b>4000</b> 1219	980	980	970	960	950	920	850	780	961
<b>6000</b> 1829	960	960	950	940	930	870	800	---	943
<b>8000</b> 2438	940	930	920	910	890	820	750	---	924
<b>10000</b> 3048	890	880	860	850	810	730	---	---	870
<b>12000</b> 3658	810	800	790	770	700	600	---	---	798
<b>14000</b> 4267	710	700	680	650	570	470	---	---	701
<b>16000</b> 4877	570	550	540	480	400	---	---	---	564
<b>18000</b> 5486	380	370	350	270	180	---	---	---	385
<b>20000</b> 6096	190	170	120	40	---	---	---	---	196

# CLIMB PERFORMANCE CRUISE CLIMB

## 05-15 Climb Performance - Cruise Climb

### Description

#### 1 Climb Performance - Cruise Climb

##### Conditions:

Power lever	90% or maximum 2300 RPM
Flaps	UP
Landing gear	retracted
Airspeed	94 KIAS

The climb performance tables show the rate of climb. The gradient of climb can be calculated using the following formula:

$$\text{Gradient [\%]} = \frac{\text{ROC [fpm]}}{\text{TAS [KTAS]}} \cdot 0.98$$

**Figure 1 - Gradient Formula**

## 05-16 Climb Performance - Cruise Climb 1999 kg

### Description

Cruise Climb - 1999 kg / 4407 lb									
<b>Flaps:</b>	UP			<b>Power:</b>	90%, max. 2300 RPM				
<b>Airspeed:</b>	94 KIAS			<b>Gear:</b>	retracted				
Press. Alt. [ft] / [m]	Rate of Climb [ft/min]								
	Outside Air Temperature - [°C] / [°F]								ISA
	-20 / -4	-10 / 14	0 / 32	10 / 50	20 / 68	30 / 86	40 / 104	50 / 122	
<b>SL</b>	810	800	800	790	780	770	740	680	786
<b>2000</b> 610	800	800	790	780	770	760	710	650	781
<b>4000</b> 1219	800	790	780	770	760	740	680	620	774
<b>6000</b> 1829	790	780	770	760	750	710	650	---	768
<b>8000</b> 2438	780	770	760	750	730	670	610	---	759
<b>10000</b> 3048	740	730	720	710	670	610	---	---	723
<b>12000</b> 3658	680	670	660	650	590	510	---	---	670
<b>14000</b> 4267	600	590	580	550	480	410	---	---	595
<b>16000</b> 4877	490	480	460	420	350	---	---	---	487
<b>18000</b> 5486	340	330	310	250	180	---	---	---	341
<b>20000</b> 6096	180	170	130	70	---	---	---	---	191



## 05-17 Climb Performance - Cruise Climb 1800 kg

### Description

Cruise Climb - 1800 kg / 3968 lb									
<b>Flaps:</b>	<b>UP</b>			<b>Power:</b>	<b>90%, max. 2300 RPM</b>				
<b>Airspeed:</b>	<b>94 KIAS</b>			<b>Gear:</b>	<b>retracted</b>				
Press. Alt. [ft] / [m]	Rate of Climb [ft/min]								
	Outside Air Temperature - [°C] / [°F]								ISA
	-20 / -4	-10 / 14	0 / 32	10 / 50	20 / 68	30 / 86	40 / 104	50 / 122	
<b>SL</b>	940	930	930	920	910	910	870	800	917
<b>2000</b> 610	940	930	920	910	910	900	840	770	913
<b>4000</b> 1219	930	920	910	910	900	870	800	740	908
<b>6000</b> 1829	920	910	910	900	880	830	770	---	902
<b>8000</b> 2438	920	910	890	880	870	800	730	---	895
<b>10000</b> 3048	870	860	850	840	800	730	---	---	856
<b>12000</b> 3658	810	800	790	780	710	620	---	---	800
<b>14000</b> 4267	730	720	700	670	600	510	---	---	719
<b>16000</b> 4877	610	590	580	520	450	---	---	---	601
<b>18000</b> 5486	440	430	410	340	260	---	---	---	441
<b>20000</b> 6096	270	250	210	140	---	---	---	---	277

## 05-18 Climb Performance - Cruise Climb 1600 kg

### Description

Cruise Climb - 1600 kg / 3527 lb									
<b>Flaps:</b>	<b>UP</b>			<b>Power:</b>	<b>90%, max. 2300 RPM</b>				
<b>Airspeed:</b>	<b>94 KIAS</b>			<b>Gear:</b>	<b>retracted</b>				
Press. Alt. [ft] / [m]	Rate of Climb [ft/min]								
	Outside Air Temperature - [°C] / [°F]								ISA
	-20 / -4	-10 / 14	0 / 32	10 / 50	20 / 68	30 / 86	40 / 104	50 / 122	
<b>SL</b>	1100	1090	1080	1080	1070	1060	1020	940	1075
<b>2000</b> 610	1090	1090	1080	1070	1060	1050	980	910	1072
<b>4000</b> 1219	1090	1080	1070	1060	1060	1030	950	870	1068
<b>6000</b> 1829	1090	1080	1070	1060	1040	990	910	---	1063
<b>8000</b> 2438	1080	1070	1060	1040	1030	950	870	---	1057
<b>10000</b> 3048	1030	1020	1010	1000	950	870	---	---	1015
<b>12000</b> 3658	970	960	940	930	850	750	---	---	953
<b>14000</b> 4267	870	860	850	820	730	620	---	---	865
<b>16000</b> 4877	740	720	710	650	560	---	---	---	734
<b>18000</b> 5486	560	540	520	440	350	---	---	---	557
<b>20000</b> 6096	370	350	310	220	---	---	---	---	375

## **TIME, FUEL DISTANCE TO CLIMB**

## 05-19 Time, Fuel and Distance to Climb 1999 kg

### Description

Time, Fuel and Distance to Climb - 1999 kg / 4407 lb								
<b>Flaps:</b>	<b>UP</b>			<b>Power:</b>	<b>90%, max. 2300 RPM</b>			
<b>Airspeed:</b>	<b>94 KIAS</b>			<b>Gear:</b>	<b>retracted</b>			
<b>Press. Alt.</b> [ft] / [m]	<b>OAT</b>	<b>OAT</b>	<b>TAS</b>	<b>RoC</b>	<b>RoC</b>	<b>Time</b>	<b>Fuel</b>	<b>Distance</b>
	[°C]	[°F]	[kt]	[ft/min]	[m/s]	[min]	[US gal]	[NM]
<b>SL</b>	15	59	92	790	4	0	0	0
<b>2000</b> 610	11	52	93	780	3.9	3	0.7	3
<b>4000</b> 1219	7	45	94	780	3.9	6	1.4	8
<b>6000</b> 1829	3	38	96	775	3.9	8	2	12
<b>8000</b> 2438	-1	30	97	770	3.9	11	2.7	16
<b>10000</b> 3048	-5	23	99	765	3.8	14	3.4	21
<b>12000</b> 3658	-9	16	100	755	3.8	16	4.1	26
<b>14000</b> 4267	-13	9	102	735	3.7	20	4.8	32
<b>16000</b> 4877	-17	2	104	710	3.6	23	5.6	39
<b>18000</b> 5486	-21	-5	105	680	3.4	27	6.5	46
<b>20000</b> 6096	-25	-12	107	640	3.2	32	7.5	55

## 05-20 Time, Fuel and Distance to Climb 1800 kg

### Description

Time, Fuel and Distance to Climb - 1800 kg / 3968 lb								
<b>Flaps:</b>	<b>UP</b>			<b>Power:</b>	<b>90%, max. 2300 RPM</b>			
<b>Airspeed:</b>	<b>94 KIAS</b>			<b>Gear:</b>	<b>retracted</b>			
<b>Press. Alt.</b> [ft] / [m]	<b>OAT</b>	<b>OAT</b>	<b>TAS</b>	<b>RoC</b>	<b>RoC</b>	<b>Time</b>	<b>Fuel</b>	<b>Distance</b>
	[°C]	[°F]	[kt]	[ft/min]	[m/s]	[min]	[US gal]	[NM]
<b>SL</b>	15	59	92	915	4.7	0	0	0
<b>2000</b> 610	11	52	93	915	4.6	3	0.6	3
<b>4000</b> 1219	7	45	94	910	4.6	5	1.2	6
<b>6000</b> 1829	3	38	96	910	4.6	7	1.7	10
<b>8000</b> 2438	-1	30	97	905	4.6	9	2.3	14
<b>10000</b> 3048	-5	23	99	900	4.5	12	2.9	18
<b>12000</b> 3658	-9	16	100	885	4.5	14	3.5	22
<b>14000</b> 4267	-13	9	102	870	4.4	17	4.1	27
<b>16000</b> 4877	-17	2	104	845	4.2	19	4.8	32
<b>18000</b> 5486	-21	-5	105	805	4.1	23	5.5	39
<b>20000</b> 6096	-25	-12	107	760	3.8	27	6.3	46

## 05-21 Time, Fuel and Distance to Climb 1600 kg

### Description

Time, Fuel and Distance to Climb - 1600 kg / 3527 lb								
<b>Flaps:</b>	<b>UP</b>			<b>Power:</b>	<b>90%, max. 2300 RPM</b>			
<b>Airspeed:</b>	<b>94 KIAS</b>			<b>Gear:</b>	<b>retracted</b>			
<b>Press. Alt.</b> [ft] / [m]	<b>OAT</b>	<b>OAT</b>	<b>TAS</b>	<b>RoC</b>	<b>RoC</b>	<b>Time</b>	<b>Fuel</b>	<b>Distance</b>
	[°C]	[°F]	[kt]	[ft/min]	[m/s]	[min]	[US gal]	[NM]
<b>SL</b>	15	59	92	1075	5.5	0	0	0
<b>2000</b> 610	11	52	93	1070	5.4	2	0.5	2
<b>4000</b> 1219	7	45	94	1070	5.4	4	1	5
<b>6000</b> 1829	3	38	96	1065	5.4	6	1.5	9
<b>8000</b> 2438	-1	30	97	1065	5.4	8	2	12
<b>10000</b> 3048	-5	23	99	1060	5.3	10	2.5	15
<b>12000</b> 3658	-9	16	100	1045	5.3	12	3	19
<b>14000</b> 4267	-13	9	102	1025	5.2	14	3.5	23
<b>16000</b> 4877	-17	2	104	1000	5	16	4	27
<b>18000</b> 5486	-21	-5	105	960	4.8	19	4.6	32
<b>20000</b> 6096	-25	-12	107	910	4.6	22	5.3	39

# CRUISE PERFORMANCE

## 05-22 Cruise Performance Description

### 1 Cruise Performance

**Conditions:**

Flaps UP  
Landing gear retracted

For conversion of OAT to delta-ISA temperatures refer to Chapter 5 [05-04 - International Standard Atmosphere - Description](#).



## 05-23 Cruise Performance 1999 kg

### Description

Cruise Performance up to 1999 kg (4407 lb)							
Press Alt. [ft] / [m]	Pwr [%]	FF [gph]	KTAS				
			ISA-10	ISA	ISA+10	ISA+20	ISA+30
<b>2000</b> 610	90	15.3	157	159	161	163	165
	75	12.4	147	149	150	152	154
	60	10.1	134	136	137	139	140
	45	7.9	118	119	120	121	122
<b>4000</b> 1219	90	15.3	161	163	164	166	168
	75	12.4	150	152	153	155	156
	60	10.1	137	138	140	141	143
	45	7.9	120	121	122	123	124
<b>6000</b> 1829	90	15.3	164	166	168	169	171
	75	12.4	153	155	156	158	159
	60	10.1	139	141	142	144	145
	45	7.9	122	123	124	125	126
<b>8000</b> 2438	90	15.3	167	169	171	173	175
	75	12.4	156	157	159	161	162
	60	10.1	142	143	145	146	148
	45	7.9	124	125	126	127	128
<b>10000</b> 3048	90	15.9	170	172	174	176	178
	75	12.4	159	160	162	164	166
	60	10.2	144	146	147	149	150
	45	7.9	126	127	128	129	130
<b>12000</b> 3658	86	14.7	170	172	174	176	178
	75	12.4	162	164	165	167	169
	60	10.3	147	149	150	152	153
	45	7.9	127	129	130	131	132
<b>14000</b> 4267	82	14.3	170	172	175	177	178
	75	12.8	165	167	168	170	172
	60	10.4	150	151	153	154	156
	45	8	129	130	131	132	133

Table 1 - Cruise Performance up to 1999 kg (4407 lb)

Cruise Performance up to 1999 kg (4407 lb)							
Press Alt. [ft] / [m]	Pwr [%]	FF [gph]	KTAS				
			ISA-10	ISA	ISA+10	ISA+20	ISA+30
<b>16000</b> 4877	75	12.9	168	170	172	174	175
	60	10.7	152	154	155	157	158
	45	8	131	132	133	134	135
<b>18000</b> 5486	68	12.1	163	165	167	169	171
	60	11	155	156	158	160	161
	45	8	133	134	135	135	136
<b>20000</b> 6096	60	11	156	158	160	162	164
	45	8.2	134	135	136	137	137

**Table 1 - Cruise Performance up to 1999 kg (4407 lb)**

# LANDING DISTANCES

## 05-24 Landing Distances

### Description

#### 1 Landing Distances

##### Conditions

Power lever	Flight Idle (FI)
Flaps	LDG, T/O or UP
Runway	dry, paved, level
Approach speed	V <sub>REF</sub>

The following factors are to be applied to the computed landing distance for the noted condition:

Headwind	Decrease by 10% for each 20 kt (10.3 m/s) headwind.
Tailwind	Increase by 10% for each 3 kt (1.5 m/s) tailwind.
Paved runway, wet	Increase by 15%.
Grass runway, dry, 5 cm (2 in) long	Increase the ground roll by 10%.
Grass runway, dry, 5 cm (2 in) to 10 cm (3.9 in) long	Increase the ground roll by 15%.
Grass runway, dry, longer than 10 cm (3.9 in)	Increase the ground roll at least by 25%.
Grass runway, wet or soft runway	Increase the ground roll by 10%.
Downhill slope:	Increase the ground roll by 20% for each 1% (1 m per 100 m or 1 ft per 100 ft) of slope.

#### WARNING

**FOR A SAFE LANDING THE AVAILABLE RUNWAY LENGTH MUST BE AT LEAST EQUAL TO THE LANDING DISTANCE OVER A 50 FT (15 M) OBSTACLE.**

#### WARNING

**POOR MAINTENANCE CONDITION OF THE AIRPLANE, DEVIATION FROM THE GIVEN PROCEDURES, UNEVEN RUNWAY, AS WELL AS UNFAVORABLE EXTERNAL FACTORS (RAIN, UNFAVORABLE WIND CONDITIONS, INCLUDING CROSS-WIND) WILL INCREASE THE LANDING DISTANCE.**

**CAUTION**

THE FACTORS IN THE ABOVE CORRECTIONS ARE TYPICAL VALUES. ON WET GROUND OR WET SOFT GRASS COVERED RUNWAYS THE LANDING DISTANCE MAY BECOME SIGNIFICANTLY LONGER THAN STATED ABOVE. IN ANY CASE THE PILOT MUST ALLOW FOR THE CONDITION OF THE RUNWAY TO ENSURE A SAFE LANDING.

THE ABOVE CORRECTIONS FOR RUNWAY SLOPE SHOULD BE USED WITH CAUTION SINCE PUBLISHED RUNWAY SLOPE DATA IS USUALLY THE NET SLOPE FROM ONE END OF THE RUNWAY TO THE OTHER. RUNWAYS MAY HAVE POSITIONS AT THEIR LENGTH AT GREATER OR LESSER SLOPES THAN PUBLISHED SLOPE, LENGTHENING (OR SHORTENING) THE LANDING ROLL ESTIMATED WITH THESE TABLES.

**NOTE**

The effect of 50% of the headwind component and 150% of the tailwind component is already incorporated in the head and tailwind factors.

## 05-25 Landing Distances 1999 kg

### Description

Landing Distance - Flaps LDG - 1999 kg / 4407 lb - [SI-units]								
<b>Weight:</b>	1999 kg / 4407 lb	<b>Flaps:</b>	LDG					
<b>V<sub>REF</sub>:</b>	77 KIAS	<b>Power:</b>	Flight Idle (FI)					
		<b>Runway:</b>	dry, paved, level					
Distances are given in meter [m]								
Press. Alt. [ft] / [m]		Outside Air Temperature - [°C] / [°F]						ISA
		0 / 32	10 / 50	20 / 68	30 / 86	40 / 104	50 / 122	
<b>SL</b>	Ground Roll	320	340	360	380	420	470	344
	15 m / 50 ft	650	670	690	720	780	870	678
<b>1000</b> 305	Ground Roll	340	370	390	410	460	520	367
	15 m / 50 ft	680	700	730	750	840	920	706
<b>2000</b> 610	Ground Roll	370	390	420	450	500	570	393
	15 m / 50 ft	710	740	770	800	890	990	737
<b>3000</b> 914	Ground Roll	400	430	450	490	560	630	422
	15 m / 50 ft	750	780	810	860	960	1060	771
<b>4000</b> 1219	Ground Roll	440	460	490	540	620	690	454
	15 m / 50 ft	790	820	850	920	1030	1140	808
<b>5000</b> 1524	Ground Roll	480	510	540	600	680	---	488
	15 m / 50 ft	830	870	910	990	1110	---	848
<b>6000</b> 1829	Ground Roll	520	560	590	670	760	---	527
	15 m / 50 ft	890	920	960	1070	1200	---	893
<b>7000</b> 2134	Ground Roll	570	610	660	750	840	---	571
	15 m / 50 ft	940	980	1040	1160	1300	---	942
<b>8000</b> 2438	Ground Roll	630	670	730	840	950	---	620
	15 m / 50 ft	1010	1050	1130	1270	1410	---	997
<b>9000</b> 2743	Ground Roll	700	750	830	940	1070	---	680
	15 m / 50 ft	1080	1130	1240	1380	1550	---	1061
<b>10000</b> 3048	Ground Roll	770	830	940	1070	---	---	745
	15 m / 50 ft	1160	1220	1360	1520	---	---	1131

Landing Distance - Flaps LDG - 1999 kg / 4407 lb - [imperial units]								
<b>Weight:</b>	1999 kg / 4407 lb			<b>Flaps:</b>	LDG			
<b>V<sub>REF</sub>:</b>	77 KIAS			<b>Power:</b>	Flight Idle (FI)			
				<b>Runway:</b>	dry, paved, level			
Distances are given in feet [ft]								
Press. Alt. [ft] / [m]		Outside Air Temperature - [°F] / [°C]						ISA
		30 / -1	50 / 10	70 / 21	90 / 32	110 / 43	130 / 54	
<b>SL</b>	Ground Roll	1050	1100	1200	1250	1400	1550	1126
	15 m / 50 ft	2150	2200	2300	2350	2600	2850	2222
<b>1000</b> 305	Ground Roll	1150	1200	1300	1350	1500	1700	1203
	15 m / 50 ft	2250	2300	2400	2500	2750	3050	2316
<b>2000</b> 610	Ground Roll	1250	1300	1400	1500	1650	1900	1288
	15 m / 50 ft	2350	2450	2500	2650	2950	3250	2418
<b>3000</b> 914	Ground Roll	1350	1400	1500	1650	1850	2050	1382
	15 m / 50 ft	2450	2550	2650	2850	3150	3500	2529
<b>4000</b> 1219	Ground Roll	1450	1550	1650	1800	2050	2300	1487
	15 m / 50 ft	2600	2700	2800	3050	3400	3750	2650
<b>5000</b> 1524	Ground Roll	1600	1700	1800	2000	2250	---	1601
	15 m / 50 ft	2750	2850	3000	3250	3650	---	2783
<b>6000</b> 1829	Ground Roll	1700	1850	1950	2200	2500	---	1729
	15 m / 50 ft	2900	3050	3150	3550	3950	---	2928
<b>7000</b> 2134	Ground Roll	1900	2000	2150	2450	2800	---	1871
	15 m / 50 ft	3100	3250	3400	3850	4250	---	3089
<b>8000</b> 2438	Ground Roll	2100	2200	2400	2750	3150	---	2032
	15 m / 50 ft	3300	3450	3700	4150	4650	---	3269
<b>9000</b> 2743	Ground Roll	2300	2450	2750	3100	3500	---	2229
	15 m / 50 ft	3550	3750	4050	4550	5100	---	3478
<b>10000</b> 3048	Ground Roll	2550	2750	3100	3500	---	---	2442
	15 m / 50 ft	3800	4000	4450	5000	---	---	3711

## 05-26 Landing Distances 1800 kg

### Description

Landing Distance - Flaps LDG - 1800 kg / 3968 lb - [SI-units]								
<b>Weight:</b>	1800 kg / 3968 lb	<b>Flaps:</b>	LDG					
<b>V<sub>REF</sub>:</b>	75 KIAS	<b>Power:</b>	Flight Idle (FI)					
		<b>Runway:</b>	dry, paved, level					
Distances are given in meter [m]								
Press. Alt. [ft] / [m]		Outside Air Temperature - [°C] / [°F]						ISA
		0 / 32	10 / 50	20 / 68	30 / 86	40 / 104	50 / 122	
<b>SL</b>	Ground Roll	290	310	320	340	380	430	313
	15 m / 50 ft	620	650	670	690	750	830	652
<b>1000</b> 305	Ground Roll	320	330	350	370	420	470	335
	15 m / 50 ft	650	680	700	720	800	880	679
<b>2000</b> 610	Ground Roll	340	360	380	410	460	520	358
	15 m / 50 ft	690	710	740	770	850	940	709
<b>3000</b> 914	Ground Roll	370	390	420	450	510	570	386
	15 m / 50 ft	720	750	780	830	920	1010	742
<b>4000</b> 1219	Ground Roll	400	430	450	500	570	640	417
	15 m / 50 ft	760	790	820	890	980	1090	778
<b>5000</b> 1524	Ground Roll	440	470	500	560	630	---	451
	15 m / 50 ft	810	840	870	960	1060	---	818
<b>6000</b> 1829	Ground Roll	480	520	550	620	700	---	489
	15 m / 50 ft	850	890	930	1030	1150	---	862
<b>7000</b> 2134	Ground Roll	530	570	610	700	790	---	532
	15 m / 50 ft	910	950	1000	1120	1250	---	911
<b>8000</b> 2438	Ground Roll	590	630	690	780	890	---	581
	15 m / 50 ft	970	1020	1090	1220	1360	---	966
<b>9000</b> 2743	Ground Roll	660	700	780	890	1010	---	638
	15 m / 50 ft	1050	1100	1200	1340	1500	---	1028
<b>10000</b> 3048	Ground Roll	730	790	890	1020	---	---	704
	15 m / 50 ft	1130	1190	1320	1480	---	---	1101



Landing Distance - Flaps LDG - 1800 kg / 3968 lb - [imperial units]								
<b>Weight:</b>	1800 kg / 3968 lb			<b>Flaps:</b>	LDG			
<b>V<sub>REF</sub>:</b>	75 KIAS			<b>Power:</b>	Flight Idle (FI)			
				<b>Runway:</b>	dry, paved, level			
Distances are given in feet [ft]								
Press. Alt. [ft] / [m]		Outside Air Temperature - [°F] / [°C]						ISA
		30 / -1	50 / 10	70 / 21	90 / 32	110 / 43	130 / 54	
<b>SL</b>	Ground Roll	950	1000	1050	1150	1250	1400	1025
	15 m / 50 ft	2050	2150	2200	2250	2450	2700	2137
<b>1000</b> 305	Ground Roll	1050	1100	1150	1250	1400	1550	1099
	15 m / 50 ft	2150	2250	2300	2400	2650	2900	2228
<b>2000</b> 610	Ground Roll	1150	1200	1250	1350	1500	1700	1174
	15 m / 50 ft	2250	2350	2400	2550	2800	3100	2326
<b>3000</b> 914	Ground Roll	1200	1300	1350	1500	1700	1900	1265
	15 m / 50 ft	2400	2450	2550	2700	3000	3350	2434
<b>4000</b> 1219	Ground Roll	1350	1400	1500	1650	1850	2100	1366
	15 m / 50 ft	2500	2600	2700	2900	3250	3600	2553
<b>5000</b> 1524	Ground Roll	1450	1550	1650	1850	2050	---	1478
	15 m / 50 ft	2650	2750	2850	3150	3500	---	2682
<b>6000</b> 1829	Ground Roll	1600	1700	1800	2050	2300	---	1603
	15 m / 50 ft	2800	2950	3050	3400	3800	---	2826
<b>7000</b> 2134	Ground Roll	1750	1850	2000	2300	2600	---	1744
	15 m / 50 ft	3000	3150	3300	3700	4100	---	2986
<b>8000</b> 2438	Ground Roll	1950	2050	2250	2600	2900	---	1905
	15 m / 50 ft	3200	3350	3600	4000	4450	---	3167
<b>9000</b> 2743	Ground Roll	2150	2300	2550	2950	3350	---	2092
	15 m / 50 ft	3450	3600	3950	4400	4900	---	3373
<b>10000</b> 3048	Ground Roll	2400	2600	2950	3350	---	---	2309
	15 m / 50 ft	3750	3900	4350	4850	---	---	3610

## 05-27 Landing Distances 1600 kg

### Description

Landing Distance - Flaps LDG - 1600 kg / 3527 lb - [SI-units]								
<b>Weight:</b>	1600 kg / 3527 lb	<b>Flaps:</b>	LDG					
<b>V<sub>REF</sub>:</b>	73 KIAS	<b>Power:</b>	Flight Idle (FI)					
		<b>Runway:</b>	dry, paved, level					
Distances are given in meter [m]								
Press. Alt. [ft] / [m]		Outside Air Temperature - [°C] / [°F]						ISA
		0 / 32	10 / 50	20 / 68	30 / 86	40 / 104	50 / 122	
<b>SL</b>	Ground Roll	260	280	290	310	340	380	279
	15 m / 50 ft	600	620	640	660	720	790	625
<b>1000</b> 305	Ground Roll	280	300	320	330	370	420	299
	15 m / 50 ft	630	650	670	690	760	840	651
<b>2000</b> 610	Ground Roll	310	320	340	370	410	460	321
	15 m / 50 ft	660	680	700	740	810	900	680
<b>3000</b> 914	Ground Roll	330	350	380	410	460	520	349
	15 m / 50 ft	690	720	740	790	870	960	713
<b>4000</b> 1219	Ground Roll	370	390	410	460	510	580	380
	15 m / 50 ft	730	760	790	850	940	1040	750
<b>5000</b> 1524	Ground Roll	410	430	460	510	580	---	413
	15 m / 50 ft	780	810	840	920	1020	---	790
<b>6000</b> 1829	Ground Roll	450	480	510	580	650	---	453
	15 m / 50 ft	830	860	900	1000	1110	---	835
<b>7000</b> 2134	Ground Roll	500	530	570	650	740	---	498
	15 m / 50 ft	890	920	970	1090	1210	---	886
<b>8000</b> 2438	Ground Roll	560	590	650	740	840	---	548
	15 m / 50 ft	950	990	1060	1190	1320	---	943
<b>9000</b> 2743	Ground Roll	620	670	740	850	960	---	608
	15 m / 50 ft	1030	1070	1170	1310	1460	---	1009
<b>10000</b> 3048	Ground Roll	710	760	860	980	---	---	679
	15 m / 50 ft	1120	1170	1300	1460	---	---	1085

Landing Distance - Flaps LDG - 1600 kg / 3527 lb - [imperial units]								
<b>Weight:</b>	1600 kg / 3527 lb			<b>Flaps:</b>	LDG			
<b>V<sub>REF</sub>:</b>	73 KIAS			<b>Power:</b>	Flight Idle (FI)			
				<b>Runway:</b>	dry, paved, level			
Distances are given in feet [ft]								
Press. Alt. [ft] / [m]		Outside Air Temperature - [°F] / [°C]						ISA
		30 / -1	50 / 10	70 / 21	90 / 32	110 / 43	130 / 54	
<b>SL</b>	Ground Roll	850	900	950	1000	1150	1250	913
	15 m / 50 ft	2000	2050	2100	2150	2350	2600	2048
<b>1000</b> 305	Ground Roll	950	1000	1050	1100	1250	1400	981
	15 m / 50 ft	2050	2150	2200	2300	2500	2750	2134
<b>2000</b> 610	Ground Roll	1000	1050	1150	1200	1350	1550	1053
	15 m / 50 ft	2150	2250	2300	2400	2700	2950	2228
<b>3000</b> 914	Ground Roll	1100	1150	1250	1350	1500	1700	1144
	15 m / 50 ft	2300	2350	2450	2600	2900	3150	2337
<b>4000</b> 1219	Ground Roll	1200	1300	1350	1500	1700	1900	1247
	15 m / 50 ft	2400	2500	2600	2800	3100	3400	2458
<b>5000</b> 1524	Ground Roll	1350	1400	1500	1700	1900	---	1355
	15 m / 50 ft	2550	2650	2750	3000	3350	---	2590
<b>6000</b> 1829	Ground Roll	1500	1600	1650	1900	2150	---	1485
	15 m / 50 ft	2750	2850	2950	3300	3650	---	2739
<b>7000</b> 2134	Ground Roll	1650	1750	1900	2150	2450	---	1632
	15 m / 50 ft	2900	3050	3200	3550	3950	---	2905
<b>8000</b> 2438	Ground Roll	1850	1950	2150	2450	2750	---	1798
	15 m / 50 ft	3150	3250	3500	3900	4350	---	3092
<b>9000</b> 2743	Ground Roll	2050	2200	2450	2800	3150	---	1994
	15 m / 50 ft	3350	3550	3850	4300	4800	---	3308
<b>10000</b> 3048	Ground Roll	2350	2500	2850	3250	---	---	2225
	15 m / 50 ft	3650	3850	4250	4800	---	---	3560

# LANDING DISTANCE ABNORMAL FLAP POSITION

## 05-28 Landing Distances - Abnormal Flap Position 1999 kg

### Description

Landing Distance - Abnormal Flap Position - 1999 kg / 4407 lb - [SI-units]								
<b>Weight:</b>	1999 kg / 4407 lb	<b>Flaps:</b>	T/O or UP					
<b>V<sub>REF</sub>:</b>	85 KIAS (Flaps T/O)	<b>Power:</b>	Flight Idle (FI)					
	94 KIAS (Flaps UP)	<b>Runway:</b>	dry, paved, level					
Distances are given in meter [m]								
Press. Alt. [ft] / [m]		Outside Air Temperature - [°C] / [°F]						ISA
		0 / 32	10 / 50	20 / 68	30 / 86	40 / 104	50 / 122	
<b>SL</b>	Ground Roll	450	470	500	530	600	670	485
	15 m / 50 ft	850	880	920	960	1050	1170	898
<b>1000</b> 305	Ground Roll	480	510	540	580	650	730	518
	15 m / 50 ft	890	930	970	1010	1120	1240	937
<b>2000</b> 610	Ground Roll	520	560	590	620	710	800	555
	15 m / 50 ft	940	980	1020	1070	1190	1330	980
<b>3000</b> 914	Ground Roll	570	600	630	690	780	880	595
	15 m / 50 ft	990	1030	1070	1150	1280	1430	1026
<b>4000</b> 1219	Ground Roll	610	650	690	760	860	970	629
	15 m / 50 ft	1050	1090	1140	1240	1380	1530	1070
<b>5000</b> 1524	Ground Roll	660	700	750	840	960	---	677
	15 m / 50 ft	1100	1150	1210	1330	1490	---	1124
<b>6000</b> 1829	Ground Roll	720	770	820	920	1040	---	730
	15 m / 50 ft	1170	1230	1290	1430	1600	---	1184
<b>7000</b> 2134	Ground Roll	790	840	900	1020	1160	---	789
	15 m / 50 ft	1250	1310	1380	1550	1740	---	1250
<b>8000</b> 2438	Ground Roll	860	910	1000	1140	1300	---	855
	15 m / 50 ft	1330	1390	1500	1690	1890	---	1323
<b>9000</b> 2743	Ground Roll	940	1010	1120	1280	1440	---	916
	15 m / 50 ft	1420	1500	1640	1840	2050	---	1394
<b>10000</b> 3048	Ground Roll	1040	1120	1240	1420	---	---	999
	15 m / 50 ft	1530	1610	1780	2010	---	---	1485

Landing Distance - Abnormal Flap Position - 1999 kg / 4407 lb - [imperial units]								
<b>Weight:</b>	1999 kg / 4407 lb			<b>Flaps:</b>	T/O or UP			
<b>V<sub>REF</sub>:</b>	85 KIAS (Flaps T/O)			<b>Power:</b>	Flight Idle (FI)			
	94 KIAS (Flaps UP)			<b>Runway:</b>	dry, paved, level			
Distances are given in feet [ft]								
Press. Alt. [ft] / [m]		Outside Air Temperature - [°F] / [°C]						ISA
		30 / -1	50 / 10	70 / 21	90 / 32	110 / 43	130 / 54	
<b>SL</b>	Ground Roll	1500	1550	1650	1750	1950	2200	1590
	15 m / 50 ft	2800	2900	3050	3150	3450	3850	2944
<b>1000</b> 305	Ground Roll	1600	1700	1800	1900	2150	2400	1700
	15 m / 50 ft	2950	3050	3200	3300	3700	4050	3074
<b>2000</b> 610	Ground Roll	1700	1850	1950	2050	2350	2650	1819
	15 m / 50 ft	3100	3200	3350	3500	3950	4350	3214
<b>3000</b> 914	Ground Roll	1850	2000	2100	2250	2550	2900	1951
	15 m / 50 ft	3250	3400	3550	3800	4200	4700	3366
<b>4000</b> 1219	Ground Roll	2050	2150	2250	2500	2850	3200	2063
	15 m / 50 ft	3450	3600	3750	4050	4550	5050	3508
<b>5000</b> 1524	Ground Roll	2150	2300	2450	2750	3150	---	2220
	15 m / 50 ft	3600	3800	3950	4400	4900	---	3687
<b>6000</b> 1829	Ground Roll	2350	2550	2700	3050	3450	---	2394
	15 m / 50 ft	3850	4050	4250	4700	5250	---	3884
<b>7000</b> 2134	Ground Roll	2600	2750	2950	3350	3850	---	2588
	15 m / 50 ft	4100	4300	4550	5100	5700	---	4100
<b>8000</b> 2438	Ground Roll	2850	3000	3300	3750	4250	---	2803
	15 m / 50 ft	4400	4600	4950	5550	6200	---	4339
<b>9000</b> 2743	Ground Roll	3100	3300	3700	4200	4700	---	3005
	15 m / 50 ft	4650	4900	5400	6050	6750	---	4573
<b>10000</b> 3048	Ground Roll	3400	3650	4100	4700	---	---	3277
	15 m / 50 ft	5050	5300	5850	6600	---	---	4870

## 05-29 Landing Distances - Abnormal Flap Position 1800 kg

### Description

Landing Distance - Abnormal Flap Position - 1800 kg / 3968 lb - [SI-units]								
<b>Weight:</b>	1800 kg / 3968 lb	<b>Flaps:</b>	T/O or UP					
<b>V<sub>REF</sub>:</b>	79 KIAS (Flaps T/O)	<b>Power:</b>	Flight Idle (FI)					
	90 KIAS (Flaps UP)	<b>Runway:</b>	dry, paved, level					
Distances are given in meter [m]								
Press. Alt. [ft] / [m]		Outside Air Temperature - [°C] / [°F]						ISA
		0 / 32	10 / 50	20 / 68	30 / 86	40 / 104	50 / 122	
<b>SL</b>	Ground Roll	410	430	460	490	530	600	443
	15 m / 50 ft	790	830	860	890	970	1080	838
<b>1000</b> 305	Ground Roll	440	470	500	520	590	660	474
	15 m / 50 ft	830	870	900	930	1040	1150	875
<b>2000</b> 610	Ground Roll	480	500	530	570	650	730	500
	15 m / 50 ft	880	910	950	1000	1110	1240	909
<b>3000</b> 914	Ground Roll	510	550	580	630	720	800	538
	15 m / 50 ft	920	960	1000	1070	1200	1320	953
<b>4000</b> 1219	Ground Roll	560	590	630	700	780	880	580
	15 m / 50 ft	970	1020	1060	1160	1280	1420	1001
<b>5000</b> 1524	Ground Roll	610	650	680	770	870	---	626
	15 m / 50 ft	1030	1080	1120	1240	1380	---	1054
<b>6000</b> 1829	Ground Roll	670	700	750	850	970	---	677
	15 m / 50 ft	1100	1140	1200	1340	1500	---	1112
<b>7000</b> 2134	Ground Roll	720	770	830	950	1070	---	724
	15 m / 50 ft	1160	1220	1300	1460	1620	---	1167
<b>8000</b> 2438	Ground Roll	800	850	940	1060	1200	---	788
	15 m / 50 ft	1250	1310	1420	1580	1770	---	1238
<b>9000</b> 2743	Ground Roll	880	950	1040	1190	1350	---	860
	15 m / 50 ft	1340	1410	1540	1730	1940	---	1318
<b>10000</b> 3048	Ground Roll	970	1040	1180	1350	---	---	944
	15 m / 50 ft	1440	1520	1690	1910	---	---	1408

Landing Distance - Abnormal Flap Position - 1800 kg / 3968 lb - [imperial units]								
<b>Weight:</b>	1800 kg / 3968 lb			<b>Flaps:</b>	T/O or UP			
<b>V<sub>REF</sub>:</b>	79 KIAS (Flaps T/O)			<b>Power:</b>	Flight Idle (FI)			
	90 KIAS (Flaps UP)			<b>Runway:</b>	dry, paved, level			
Distances are given in feet [ft]								
Press. Alt. [ft] / [m]		Outside Air Temperature - [°F] / [°C]						ISA
		30 / -1	50 / 10	70 / 21	90 / 32	110 / 43	130 / 54	
<b>SL</b>	Ground Roll	1350	1450	1500	1600	1750	2000	1452
	15 m / 50 ft	2600	2700	2850	2950	3200	3550	2747
<b>1000</b> 305	Ground Roll	1450	1550	1650	1700	1950	2200	1555
	15 m / 50 ft	2750	2850	3000	3050	3400	3800	2869
<b>2000</b> 610	Ground Roll	1600	1650	1750	1900	2150	2400	1640
	15 m / 50 ft	2900	3000	3100	3300	3650	4050	2981
<b>3000</b> 914	Ground Roll	1700	1800	1900	2100	2350	2600	1764
	15 m / 50 ft	3050	3150	3300	3550	3950	4350	3125
<b>4000</b> 1219	Ground Roll	1850	1950	2100	2300	2600	2900	1902
	15 m / 50 ft	3200	3350	3500	3800	4200	4700	3283
<b>5000</b> 1524	Ground Roll	2000	2150	2250	2500	2850	---	2053
	15 m / 50 ft	3400	3550	3700	4100	4550	---	3456
<b>6000</b> 1829	Ground Roll	2200	2300	2450	2800	3200	---	2221
	15 m / 50 ft	3600	3750	3950	4400	4950	---	3646
<b>7000</b> 2134	Ground Roll	2400	2550	2750	3150	3500	---	2373
	15 m / 50 ft	3850	4000	4250	4800	5300	---	3827
<b>8000</b> 2438	Ground Roll	2600	2800	3100	3450	3950	---	2583
	15 m / 50 ft	4100	4300	4650	5200	5800	---	4060
<b>9000</b> 2743	Ground Roll	2900	3100	3400	3900	4450	---	2822
	15 m / 50 ft	4400	4650	5050	5700	6350	---	4322
<b>10000</b> 3048	Ground Roll	3200	3400	3850	4450	---	---	3094
	15 m / 50 ft	4750	5000	5550	6250	---	---	4618



## 05-30 Landing Distances - Abnormal Flap Position 1600 kg

### Description

Landing Distance - Abnormal Flap Position - 1600 kg / 3527 lb - [SI-units]								
<b>Weight:</b>	1600 kg / 3527 lb			<b>Flaps:</b>	T/O or UP			
<b>V<sub>REF</sub>:</b>	77 KIAS (Flaps T/O)			<b>Power:</b>	Flight Idle (FI)			
	84 KIAS (Flaps UP)			<b>Runway:</b>	dry, paved, level			
Distances are given in meter [m]								
Press. Alt. [ft] / [m]		Outside Air Temperature - [°C] / [°F]						ISA
		0 / 32	10 / 50	20 / 68	30 / 86	40 / 104	50 / 122	
<b>SL</b>	Ground Roll	370	390	410	430	480	540	394
	15 m / 50 ft	730	760	780	810	890	990	766
<b>1000</b> 305	Ground Roll	390	420	440	470	530	600	423
	15 m / 50 ft	760	790	830	860	960	1060	800
<b>2000</b> 610	Ground Roll	430	460	480	520	590	650	455
	15 m / 50 ft	800	840	870	920	1030	1130	838
<b>3000</b> 914	Ground Roll	470	500	530	570	640	730	491
	15 m / 50 ft	850	890	930	980	1100	1220	880
<b>4000</b> 1219	Ground Roll	510	550	570	630	720	810	531
	15 m / 50 ft	900	940	980	1060	1180	1310	926
<b>5000</b> 1524	Ground Roll	550	590	630	700	800	---	566
	15 m / 50 ft	950	1000	1040	1150	1280	---	969
<b>6000</b> 1829	Ground Roll	610	650	690	790	880	---	615
	15 m / 50 ft	1010	1060	1110	1250	1380	---	1025
<b>7000</b> 2134	Ground Roll	670	720	770	870	990	---	671
	15 m / 50 ft	1080	1140	1210	1350	1510	---	1087
<b>8000</b> 2438	Ground Roll	740	780	860	980	1120	---	734
	15 m / 50 ft	1170	1220	1310	1480	1650	---	1156
<b>9000</b> 2743	Ground Roll	820	880	980	1120	1250	---	795
	15 m / 50 ft	1250	1320	1440	1630	1810	---	1226
<b>10000</b> 3048	Ground Roll	920	980	1110	1260	---	---	879
	15 m / 50 ft	1360	1430	1600	1790	---	---	1317

Landing Distance - Abnormal Flap Position - 1600 kg / 3527 lb - [imperial units]								
<b>Weight:</b>	1600 kg / 3527 lb			<b>Flaps:</b>	T/O or UP			
<b>V<sub>REF</sub>:</b>	77 KIAS (Flaps T/O)			<b>Power:</b>	Flight Idle (FI)			
	84 KIAS (Flaps UP)			<b>Runway:</b>	dry, paved, level			
Distances are given in feet [ft]								
Press. Alt. [ft] / [m]		Outside Air Temperature - [°F] / [°C]						ISA
		30 / -1	50 / 10	70 / 21	90 / 32	110 / 43	130 / 54	
<b>SL</b>	Ground Roll	1250	1300	1350	1450	1600	1800	1290
	15 m / 50 ft	2400	2500	2600	2700	2950	3250	2511
<b>1000</b> 305	Ground Roll	1300	1400	1450	1550	1750	2000	1386
	15 m / 50 ft	2500	2600	2700	2850	3150	3500	2625
<b>2000</b> 610	Ground Roll	1400	1500	1600	1700	1950	2150	1491
	15 m / 50 ft	2650	2750	2900	3050	3400	3700	2749
<b>3000</b> 914	Ground Roll	1550	1650	1750	1850	2100	2400	1609
	15 m / 50 ft	2800	2900	3050	3250	3600	4000	2886
<b>4000</b> 1219	Ground Roll	1700	1800	1900	2100	2350	2650	1741
	15 m / 50 ft	2950	3100	3200	3500	3900	4300	3037
<b>5000</b> 1524	Ground Roll	1800	1950	2050	2300	2650	---	1856
	15 m / 50 ft	3150	3250	3450	3800	4200	---	3179
<b>6000</b> 1829	Ground Roll	2000	2150	2300	2600	2900	---	2017
	15 m / 50 ft	3350	3500	3650	4100	4550	---	3361
<b>7000</b> 2134	Ground Roll	2200	2350	2550	2850	3250	---	2200
	15 m / 50 ft	3550	3750	4000	4450	4950	---	3564
<b>8000</b> 2438	Ground Roll	2450	2600	2850	3250	3700	---	2407
	15 m / 50 ft	3850	4000	4300	4850	5450	---	3793
<b>9000</b> 2743	Ground Roll	2700	2900	3200	3700	4100	---	2608
	15 m / 50 ft	4100	4350	4750	5350	5950	---	4022
<b>10000</b> 3048	Ground Roll	3000	3250	3650	4150	---	---	2883
	15 m / 50 ft	4450	4700	5250	5850	---	---	4320

# GO AROUND CLIMB PERFORMANCE

## 05-31 Go-Around Climb Performance

### Description

#### 1 Go Around Climb Performance

##### Conditions:

Power lever	MAX
Flaps	LDG
Landing gear	extended
Airspeed	V <sub>REF</sub>

The climb performance tables show the rate of climb. The gradient and angle of climb can be calculated using the following formula:

$$\text{Gradient [\%]} = \frac{\text{ROC [fpm]}}{\text{TAS [KTAS]}} \cdot 0.98$$

**Figure 1 - Gradient Formula**

#### **NOTE**

Rate of climb at MSL and ISA conditions:  
3.6 ° for Maximum Take-Off Mass (1999 kg / 4407 lb).

## 05-32 Go-Around Climb Performance 1999 kg

### Description

Go-Around Climb Performance - 1999 kg / 4407 lb									
<b>Flaps:</b>	<b>LDG</b>			<b>Power:</b>	<b>MAX</b>				
<b>Airspeed:</b>	<b>77 KIAS</b>			<b>Gear:</b>	<b>extended</b>				
<b>Press. Alt. [ft] / [m]</b>	<b>Rate of Climb [ft/min]</b>								
	<b>Outside Air Temperature - [°C] / [°F]</b>								<b>ISA</b>
	<b>-20 / -4</b>	<b>-10 / 14</b>	<b>0 / 32</b>	<b>10 / 50</b>	<b>20 / 68</b>	<b>30 / 86</b>	<b>40 / 104</b>	<b>50 / 122</b>	
<b>SL</b>	495	485	475	460	445	430	390	335	452
<b>2000</b> 610	485	470	455	445	430	410	350	300	442
<b>4000</b> 1219	470	455	440	425	410	375	315	265	432
<b>6000</b> 1829	455	440	425	405	390	345	280	---	418
<b>8000</b> 2438	435	420	400	385	365	305	245	---	404
<b>10000</b> 3048	280	265	245	230	195	130	---	---	255

## 05-33 Go-Around Climb Performance 1800 kg

### Description

Go-Around Climb Performance - 1800 kg / 3968 lb									
<b>Flaps:</b>	<b>LDG</b>			<b>Power:</b>	<b>MAX</b>				
<b>Airspeed:</b>	<b>75 KIAS</b>			<b>Gear:</b>	<b>extended</b>				
<b>Press. Alt. [ft] / [m]</b>	<b>Rate of Climb [ft/min]</b>								
	<b>Outside Air Temperature - [°C] / [°F]</b>								<b>ISA</b>
	<b>-20 / -4</b>	<b>-10 / 14</b>	<b>0 / 32</b>	<b>10 / 50</b>	<b>20 / 68</b>	<b>30 / 86</b>	<b>40 / 104</b>	<b>50 / 122</b>	
<b>SL</b>	610	600	585	575	560	545	495	430	566
<b>2000</b> 610	600	585	570	555	545	525	455	395	556
<b>4000</b> 1219	585	570	555	540	525	490	420	355	545
<b>6000</b> 1829	570	555	540	520	505	450	380	NaN	534
<b>8000</b> 2438	555	535	520	500	480	410	340	NaN	519
<b>10000</b> 3048	385	365	350	330	295	220	NaN	NaN	358

## 05-34 Go-Around Climb Performance 1600 kg

### Description

Go-Around Climb Performance - 1600 kg / 3527 lb									
<b>Flaps:</b>	<b>LDG</b>			<b>Power:</b>	<b>MAX</b>				
<b>Airspeed:</b>	<b>73 KIAS</b>			<b>Gear:</b>	<b>extended</b>				
<b>Press. Alt. [ft] / [m]</b>	<b>Rate of Climb [ft/min]</b>								
	<b>Outside Air Temperature - [°C] / [°F]</b>								<b>ISA</b>
	<b>-20 / -4</b>	<b>-10 / 14</b>	<b>0 / 32</b>	<b>10 / 50</b>	<b>20 / 68</b>	<b>30 / 86</b>	<b>40 / 104</b>	<b>50 / 122</b>	
<b>SL</b>	745	735	720	710	695	685	625	550	703
<b>2000</b> 610	735	725	710	695	680	660	580	510	693
<b>4000</b> 1219	725	710	695	680	665	620	545	470	682
<b>6000</b> 1829	710	690	675	660	645	580	500	---	671
<b>8000</b> 2438	690	675	655	640	615	535	455	---	659
<b>10000</b> 3048	510	490	470	455	410	330	---	---	481

# GLIDE



## 05-35 Glide

### Description

#### 1 Glide

#### CAUTION

THE PROPELLER WILL KEEP WINDMILLING UNDER ALL EXPECTED CONDITIONS. DO NOT ATTEMPT TO STOP THE PROPELLER INTENTIONALLY.

The following table shows the glide ratio and the resulting maximum horizontal distance in nautical miles per 1000 ft (~300 m) of altitude loss in a glide traveled in still air.

	Glide ratio	Maximum horizontal distance per 1000 ft (~300 m) altitude loss
Windmilling propeller	10.0	1.6 NM (~ 3.0 km)

Table 1 - Glide

#### Conditions:

FLAPS UP  
Gear UP  
COWL FLAP CLOSED  
Airspeed 94 KIAS

#### NOTE

In case of a stationary propeller the given numbers are conservative.

## APPROVED NOISE DATA

## 05-36 Approved Noise Data

### Description

#### 1 Approved Noise Data

ICAO Annex 16, Vol. 1 85.0 dB(A)  
Chapter 10

If MÄM 50-110 is installed:

ICAO Annex 16, Vol. 1 82.5 dB(A)  
Chapter 10

No determination has been made by the Federal Aviation Administration that the noise levels of this aircraft are or should be acceptable or unacceptable for operation at, into, or out of, any airport.

**06**  
**MASS AND BALANCE / EQUIPMENT**

# MASS AND BALANCE

## 06-01 General

### Description

#### 1 Introduction

In order to achieve the performance and flight characteristics described in this Airplane Flight Manual and for safe flight operation, the airplane must be operated within the permissible mass and balance envelope.

The pilot is responsible for adhering to the permissible values for loading and center of gravity (CG). In this, he should note the movement of the CG due to fuel consumption. The permissible CG range during flight is given in [02-07 - Center of Gravity - Description](#).

The procedure for determining the flight mass CG position is described in this chapter. Additionally a comprehensive list of the equipment approved for this airplane exists (Equipment List). The set of items marked as 'installed' constitutes the Equipment Inventory.

Before the airplane is delivered, the empty mass and the corresponding CG position are determined and entered in [06-03 - Mass and Balance Report - Description](#).

Following equipment changes the new empty mass and the corresponding CG position must be determined by calculation or by weighing.

Following repairs or repainting the new empty mass and the corresponding CG position must be determined by weighing.

Empty mass, empty mass CG position, and the empty mass moment must be certified in the Mass and Balance Report by authorized personnel.

For conversion of SI units to US units and vice versa refer to [01-05 - Conversion Factors - Description](#).

## 06-02 Datum Plane

### Description

#### 1 Datum Plane

The Datum Plane (DP) is a plane which is normal to the airplane's longitudinal axis and in front of the nose landing gear as seen from the direction of flight. When the airplane is aligned horizontally by means of the weighing tool, the Datum Plane is vertical. The Datum Plane is located 2.196 meters (86.46 in) in front of the leading edge of the wing at the root rib. See [Figure 1](#).

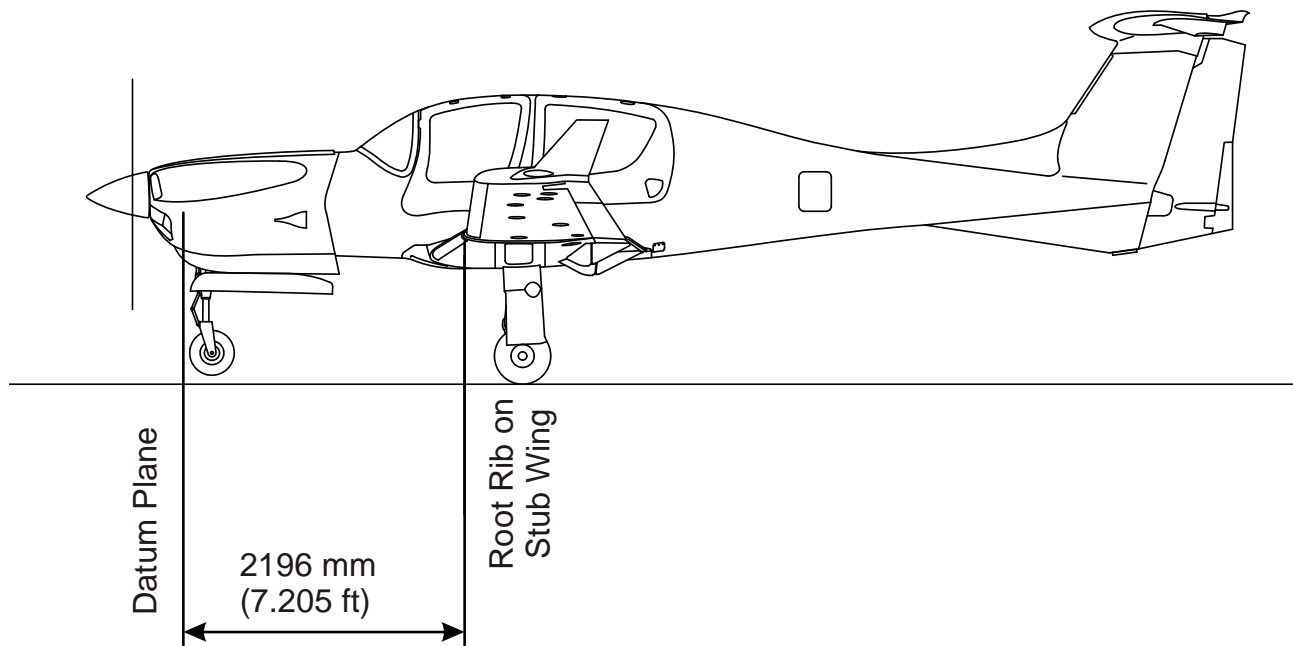

Figure 1 - Datum Plane

## 06-03 Mass and Balance Report

### Description

#### 1 Mass and Balance Report

##### 1 Mass and Balance Report Conditions

The empty mass and the corresponding CG position established before delivery are the first entries in the Mass and Balance Report. Every change in permanently installed equipment, and every repair to the airplane which affects the empty mass or the empty mass CG must be recorded in the Mass and Balance Report.

For the calculation of flight mass and corresponding CG position (or moment), the current empty mass and the corresponding CG position (or moment) in accordance with the Mass and Balance Report must always be used.

Condition of the airplane for establishing the empty mass:

- Equipment as per Equipment Inventory
- Including the following operating fluids:
  - brake fluid
  - hydraulic fluid (for the retractable landing gear)
  - engine oil (12 liters = 12.7 qts)
  - coolant (12 liters = 12.7 qts)
  - gearbox oil (1.8 liters = 1.9 qts)
  - unusable fuel in LH (main) fuel tanks (1 US gal = 3.8 liters)
  - unusable fuel in RH (aux) fuel tanks (1.5 US gal = 5.7 liters)

##### 2 Mass and Balance Report





## 06-04 Flight Mass and Center of Gravity

### Description

#### 1 Flight Mass and Center of Gravity

The following information enables you to operate your DA 50 C within the permissible mass and balance limits. For the calculation of the flight mass and the corresponding CG position the following tables and diagrams are required:

- [06-05 - Moment Arms - Description](#)
- [06-06 - Loading Diagram - Description](#)
- [06-07 - Calculation of Loading Condition - Description](#)
- [06-08 - Permissible Center of Gravity Range - Description](#)
- [06-09 - Permissible Moment Range - Description](#)

The diagrams should be used as follows:

- A. Take the empty mass and the empty mass moment of your airplane from the Mass and Balance Report, and enter the figures in the appropriate boxes under the column marked 'Your DA 50 C' in Table [06-07 - Calculation of Loading Condition - Description](#).
- B. Read the fuel quantity indicators to determine the fuel quantity in the main fuel tanks.
- C. Multiply the individual masses by the moment arms quoted to obtain the moment for every item of loading and enter these moments in the appropriate boxes in Table [06-07 - Calculation of Loading Condition - Description](#).
- D. Add up the masses and moments in the respective columns. The CG position is calculated by dividing the total moment by the total mass (using row 8 for the condition with empty fuel tanks, and row 10 for the pre take-off condition). The resulting CG position must be inside the limits. As an illustration the total mass and the CG position are entered in the Diagram in [06-08 - Permissible Center of Gravity Range - Description](#). This checks graphically that the current configuration of the airplane is within the permissible range.
- E. Graphical method:  
[06-06 - Loading Diagram - Description](#) is used to determine the moments. The masses and moments for the individual items of loading are added. Then [06-09 - Permissible Moment Range - Description](#) is used to check whether the total moment associated with the total mass is in the permissible range.  
The result found with the graphical method is however inaccurate. In doubtful cases the result must be verified using the exact method given above.

## 06-05 Moment Arms

### Description

#### 1 Moment Arms

Table 1 shows the most important lever arms aft of the Datum Plane:

Item	Lever Arm	
	[m]	[in]
Occupants on front seats	2.24	88.2
Occupants on rear seats	3.13	123.2
Fuel	2.63	103.5
Baggage in Area A and Compartment C	3.98	156.7
Baggage in Area B and Compartment D	4.35	171.3
Trim Weight (1.0 to 20.0 kg [2.2 to 44.1 lb])	7.06	277.95

**Table 1 - Moment Arms**

## 06-06 Loading Diagram Description

### 1 Loading Diagram

Figure 2 shows the loading diagram.

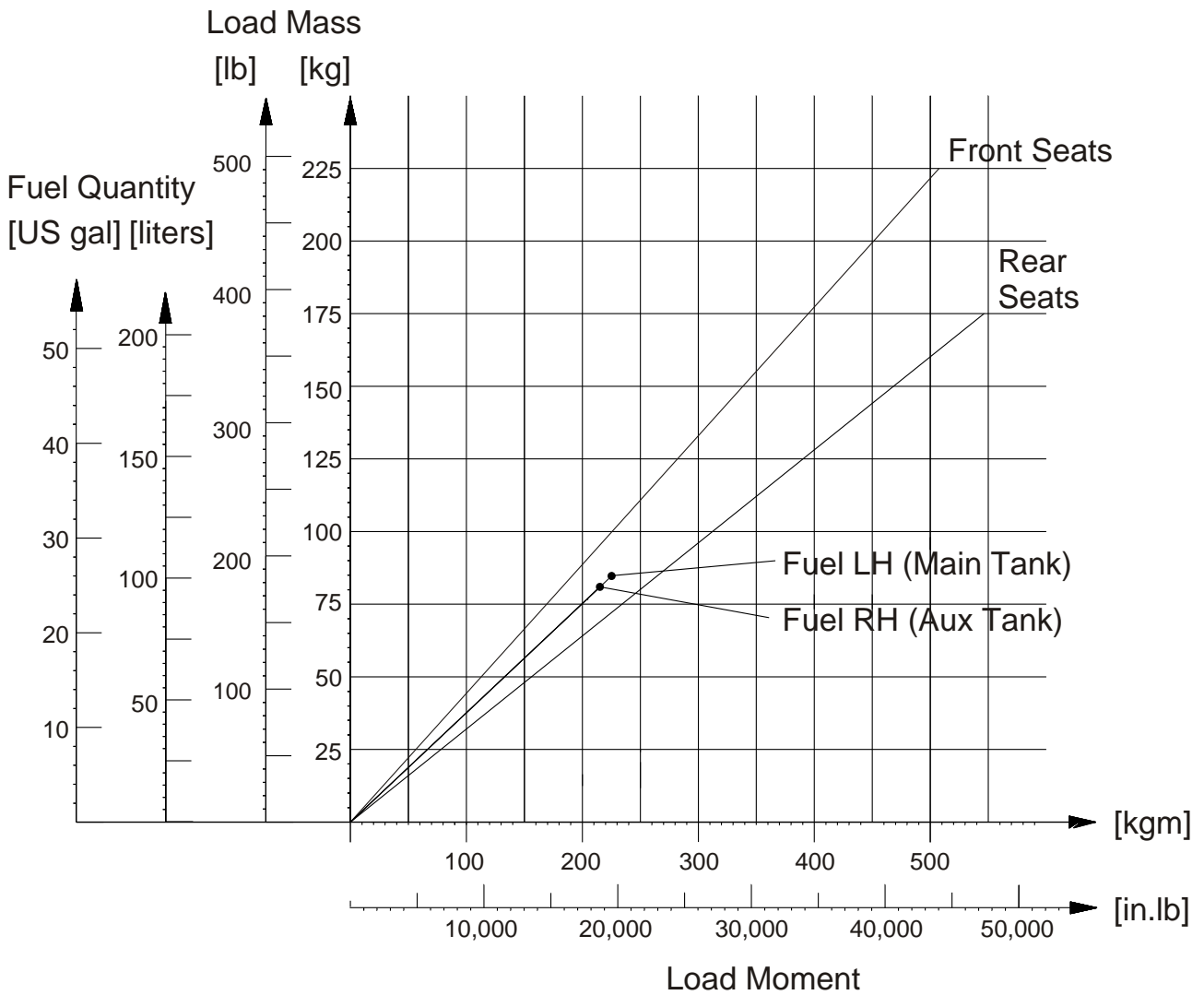

Figure 2 - Loading Diagram

---

## 06-07 Calculation of Loading Condition Description

### 1 Calculation of Loading Condition

Complete one of the following forms. (Either in metric or imperial dimensions).

Divide the total moments from rows 8 and 10 by the related total mass to obtain the CG positions.

Locate the values in the diagram in [06-08 - Permissible Center of Gravity Range - Description](#). If the CG positions and related masses fall into the permitted area, the loading condition is allowable. Our example shows allowable loading conditions.

CALCULATION OF LOADING CONDITION - Metric		Your DA 50 C	
		Mass [kg]	Moment [kgm]
1	Empty mass (from Mass and Balance Report)		
2	Front seats Lever arm: 2.24 m		
3	Passenger seats Lever arm: 3.13 m		
4	Baggage in Area A Lever arm: 3.98 m		
5	Baggage in Area B Lever arm: 4.35 m		
6	Baggage in Compartment C Lever arm: 3.98 m		
7	Baggage in Compartment D Lever arm: 4.35 m		
8	Total mass and total moment with empty fuel tanks (Total of 1.-7.)		
9	Usable fuel, main tanks (0.84 kg/liter) Lever arm: 2.63 m		
10	Total mass and total moment with fuel (Total of 8. - 9.)		

**Table 1 - Calculation of Loading Condition**

CALCULATION OF LOADING CONDITION - Imperial		Your DA 50 C	
		Mass [lb]	Moment [in.lb]
1	Empty mass (from Mass and Balance Report)		
2	Front seats Lever arm: 88.2 in		
3	Passenger seats row Lever arm: 123.2 in		
4	Baggage in Area A Lever arm: 156.7 in		
5	Baggage in Area B Lever arm: 171.3 in		
6	Baggage in Compartment C Lever arm: 156.7 in		
7	Baggage in Compartment D Lever arm: 171.3 in		
8	Total mass and total moment with empty fuel tanks (Total of 1.-7.)		
9	Usable fuel, main tanks (0.84 kg/liter) Lever arm: 103.5 in		
10	Total mass and total moment with fuel (Total of 8. - 9.)		

**Table 2 - Calculation of Loading Condition - Imperial**

EXAMPLE CALCULATION OF LOADING CONDITION - Metric and Imperial		Example DA 50 C	
		Mass [kg] [lb]	Moment [kgm] [in.lb]
1	Empty mass (from Mass and Balance Report)	1480 kg 3263 lb	3560.9 kgm 309,073 in.lb
2	Front seats Lever arm: 2.24 m 88.2 in	160 kg 353 lb	358.4 kgm 31,135 in.lb
3	Passenger seats Lever arm: 3.13 m 123.2 in	75 kg 165 lb	234.8 kgm 20,328 in.lb
4	Baggage in Area A Lever arm: 3.98 m Lever arm: 156.7 in	10 kg 22 lb	39.8 kgm 3,447 in.lb
5	Baggage in Area B Lever arm: 4.35 m Lever arm: 171.3 in	10 kg 22 lb	43.5 kgm 3,769 in.lb
6	Baggage in Compartment C Lever arm: 3.98 m Lever arm: 156.7 in	5 kg 11 lb	19.9 kgm 1,724 in.lb
7	Baggage in Compartment D Lever arm: 4.35 m Lever arm: 171.3 in	5 kg 11 lb	21.8 kgm 1,884 in.lb
8	Total mass and total moment with empty fuel tanks (Total of 1.-7.)	1745 kg 3847 lb	4279.1 kgm 371,360 in.lb
9	Usable fuel, main tanks (0.84 kg/liter) Lever arm: 2.63 m 103.5 in	90 kg 198 lb	236.7 kgm 20,493 in.lb
10	Total mass and total moment with fuel (Total of 8. - 9.)	1835 kg 4045 lb	4515.8 kgm 391,853 in.lb

Table 3 - Example Calculation of Loading Condition



## 06-08 Permissible Center of Gravity Range Description

### 1 Permissible Center of Gravity Range

Figure 3 shows the permissible center of gravity range.

The flight CG position must be within the following limits:

Most forward flight CG:

- 2.315 m aft of datum plane at 1480 kg to 1750 kg
- 2.315 m aft of datum plane at 1750, increasing linearly to (see next row)
- 2.42 m aft of datum plane at 1999 kg

Most rearward flight CG:

- 2.355 m aft of datum plane at 1480 kg, increasing linearly to (see next row)
- 2.458 m aft of datum plane at 1645 kg, increasing linearly to (see next row)
- 2.47 m aft of datum plane at 1999 kg

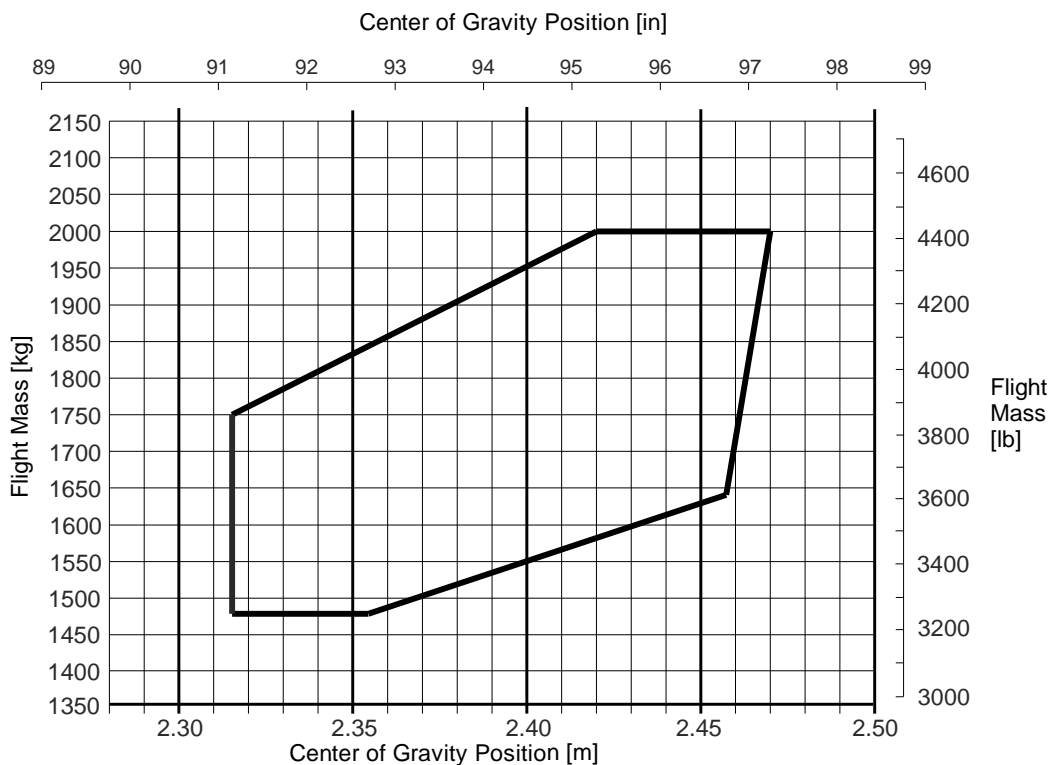

**Figure 3 - Permissible Center of Gravity Range**

## 06-09 Permissible Moment Range Description

### 1 Permissible Moment Range

Figure 4 shows the permissible moment range.

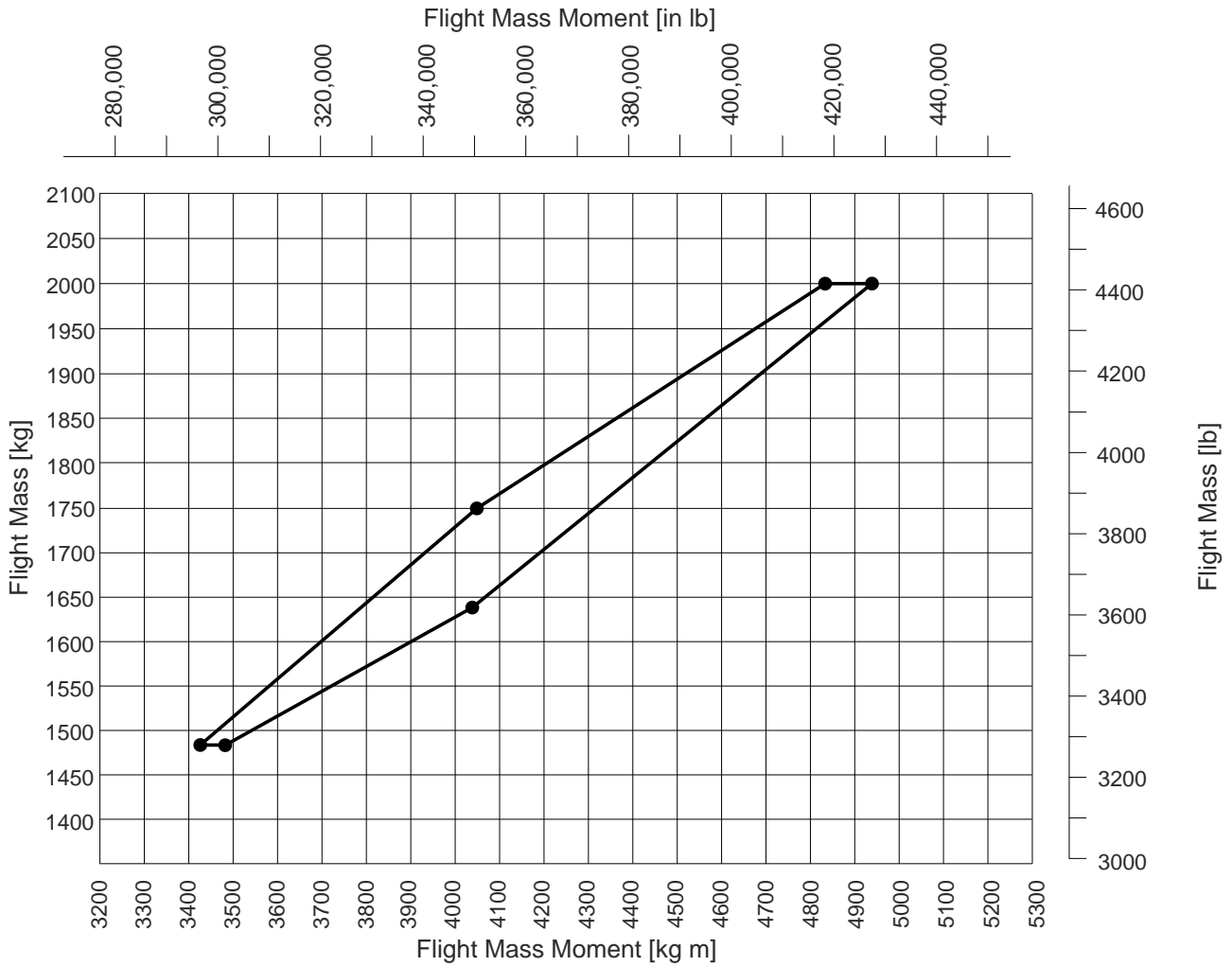

Figure 4 - Permissible Moment Range

# EQUIPMENT LIST

## 06-10 Equipment Description

### 1 Equipment List and Equipment Inventory

All equipment that is approved for installation in the DA 50 C is shown in the Equipment List below.

#### **NOTE**

The equipment listed below cannot be installed in any arbitrary combination. The airplane manufacturer must be contacted before removing or installing equipment, with the exception of replacing a unit by an identical unit.

The items of equipment installed in your particular airplane are indicated in the appropriate column. The set of items marked as 'installed' constitutes the Equipment Inventory.

Airplane Serial No.:		Registration:			Date:			Mass		Lever Arm	
Description	Type	Part No.	Manufacturer	S/N	ins	lb	kg	in	m		
<b>AVIONICS COOLING</b>											
Avionics cooling fan	SAFE 328	305 467-00	Sandia Aerospace	-----							
PFD cooling fan	SAFE 128	305 468-00	Sandia Aerospace	-----							
MFD cooling fan	SAFE 128	305 468-00	Sandia Aerospace	-----							
<b>AUTOPILOT SYSTEM</b>											
Pitch servo	GSA 81	011-00878-20	Garmin								
Pitch servo mount	GSM 86	011-01904-03	Garmin								
Pitch clutch cartridge		011-02147-03	Garmin	-----							
Roll servo	GSA 81	011-00878-20	Garmin								
Roll servo mount	GSM 86	011-01904-03	Garmin								
Roll clutch cartridge		011-02147-09	Garmin	-----							
Pitch trim servo	GSA 81	011-00878-20	Garmin								
Pitch trim servo mount	GSM 86	011-01904-03	Garmin								
Pitch trim clutch cartridge		011-02147-09	Garmin	-----							
Yaw servo	GSA 80	011-00877-20	Garmin								
Yaw servo mount	GSM 86	011-01904-03	Garmin								
Yaw clutch cartridge		011-02147-03	Garmin	-----							

Table 1 - Equipment List

Airplane Serial No.:		Registration:			Date:			Mass		Lever Arm	
Description	Type	Part No.	Manufacturer	S/N	ins	lb	kg	in	m		
<b>ELECTRICAL POWER</b>											
Main battery	RG24-15		Concorde	-----							
Excitation battery 1 (2 pcs.)	LC-R121R3P		Panasonic	-----							
Excitation battery 2 (2 pcs.)	LC-R127R2P		Panasonic	-----							
<b>EQUIPMENT</b>											
Safety belt, pilot	5-01-() Series	5-01-2Y07()	Schroth								
Safety belt, co-pilot	5-01-() Series	5-01-2Y57()	Schroth								
Safety belt, LH pax	5-02-() Series	5-02-BJ57()	Schroth								
Safety belt, RH pax	5-02-() Series	5-02-BK57()	Schroth								
Safety belt, center pax	5-02-() Series	5-02-BL57()	Schroth								
ELT unit	406 Integra	S1851501-02	Kannad								
ELT remote switch	RC200	S1820513-11	Kannad	-----							
ELT antenna	AV-300	0146151	Kannad	-----							
<b>SAFETY EQUIPMENT</b>											
Fire extinguisher		A620T	Amerex	-----							

Table 1 - Equipment List

Airplane Serial No.:		Registration:		Date:		Mass		Lever Arm	
Description	Type	Part No.	Manufacturer	S/N	ins	lb	kg	in	m
Fire extinguisher		337TS	Amerex	-----					
First aid kit				-----					
Emergency egress hammer		D64-2560-70-50	Diamond Aircraft	-----					
<b>FLIGHT CONTROLS</b>									
Lift transducer		C-99707-2	Safeflight Instrument Corp						
Stall warning computer		C-99706-2	Safeflight Instrument Corp						
<b>INDICATING / REC. SYSTEM</b>									
Primary flight display (PFD)	GDU 1050	011-03470-00	Garmin						
Multi function display (MFD)	GDU 1055	011-03470-80	Garmin						
Control unit	GCU 476	011-01237-10	Garmin						
Control unit	GCU 476	011-04476-00	Garmin						

Table 1 - Equipment List

Airplane Serial No.:		Registration:			Date:		Mass		Lever Arm	
Description	Type	Part No.	Manufacturer	S/N	ins	lb	kg	in	m	
<b>LIGHTS</b>										
Area Dome light		CL 13 625-1	Birk Aerosystems	-----						
Strobe / Pos. light assy LH	OR6002R	01-0771733-12	Whelen	-----						
Strobe / Pos. light assy RH	OR6002G	01-0771733-11	Whelen	-----						
Map / Reading lights (4 pcs.)		RL6961-1	Birk Aerosystems	-----						
Taxi light	Xenon D1S		XE Vision	-----						
Taxi light power supply		XV4D-35	XE Vision	-----						
Landing light	Xenon D1S		XE Vision	-----						
Landing light power supply		XV4D-35	XE Vision	-----						
<b>COMMUNICATION / NAVIGATION</b>										
Satellite Transceiver	GSR 56	011-02268-00	Garmin							
Iridium Antenna	CI 490-1		Comant							
Iridium Antenna	CI 490-490		Comant							
COMM #1 / GPS #2 antenna		CI 2580-200	Comant	-----						
COMM #2 antenna		CI 292-2	Comant	-----						
Audio panel / Marker / ICS	GMA 1360	011-03568-00	Garmin							
Pitot / Static probe, heated		PST300-AR-1	Aerosonic	-----						
Pitot / Static probe, heated		PST300-AR-2	Aerosonic	-----						
Alternate static valve		DA4-3111-51-00	Diamond Aircraft	-----						

Table 1 - Equipment List



Airplane Serial No.:		Registration:		Date:		Mass		Lever Arm	
Description	Type	Part No.	Manufacturer	S/N	ins	lb	kg	in	m
Standby Attitude Module	MD302	6420302-1	Mid Continent Instr.						
Magnetic compass		NV2C-28V	SIRS Navigation	-----					
OAT probe	GTP 59	011-00978-00	Garmin						
Digital air data system	GDC 72	011-03734-00	Garmin						
Digital air data system	GDC 72	011-03734-01	Garmin						
Integrated avionics #1	GIA 64W	011-03711-00	Garmin						
Integrated avionics #2	GIA 64W	011-03711-00	Garmin						
Integrated avionics #1	GIA 64W	011-03711-01	Garmin						
Integrated avionics #2	GIA 64W	011-03711-01	Garmin						
Transponder	GTX 335R	011-03301-00	Garmin						
Transponder	GTX 345R	011-03303-00	Garmin						
Transponder	GTX 345R	011-03303-01	Garmin						
AHRS	GRS 79	011-03732-00	Garmin						
Magnetometer	GMU 44	011-00870-10	Garmin						
Magnetometer	GMU 44B	011-04201-00	Garmin						
Data link receiver	GDL 69A SXM	011-03177-15	Garmin						
Dual VOR / dual GS duplexer	CI 1125		Comant	-----					
LH: VOR / LOC / GS antenna	CI120G/S		Comant	-----					
RH: VOR / LOC / GS antenna	CI120G/S		Comant	-----					
VOR / LOC / GS PWR combiner	CI120-3		Comant	-----					
Transponder antenna	KA 61	071-00221-0010	Bendix/King						

Table 1 - Equipment List

Airplane Serial No.:		Registration:			Date:		Mass		Lever Arm	
Description	Type	Part No.	Manufacturer	S/N	ins	lb	kg	in	m	
Transponder antenna	CI 105-16		Comant							
Marker antenna	CI 102		Comant							
GPS #1 antenna	GA 36	013-00244-00	Garmin							
GPS #1/XM antenna	GA 37	013-00245-00	Garmin							
DME	KN 63	066-1070-01	Bendix/King							
DME antenna	KA 61	071-00221-0010	Bendix/King							
DME antenna	CI 105-16		Comant							
TAS processor	TAS 600A	700-00185-000	Avidyne							
TAS processor	TAS 605A	700-00185-001	Avidyne							
TAS processor	TAS 610A	700-00185-002	Avidyne							
TAS processor	TAS 615A	700-00185-003	Avidyne							
TAS processor	TAS 620A	700-00185-004	Avidyne							
Transponder coupler		70-2040	Avidyne							
TAS antenna, top		S72-1750-31L	Sensor Systems							
TAS antenna, bottom		S72-1750-32L	Sensor Systems							
Stormscope	WX-500	805-11500-001	L-3							
Stormscope antenna	NY-163	805-10930-001	L-3							
ADF receiver	RA 3502-(01)	0505.757-912	Becker							
ADF / RMI converter	AC 3504-(01)	0856.010-912	Becker							
ADF antenna	AN 3500	0832.601-912	Becker							
Flight Stream 510		011-03595-00	Garmin	-----						

Table 1 - Equipment List

Airplane Serial No.:		Registration:			Date:		Mass		Lever Arm	
Description	Type	Part No.	Manufacturer	S/N	ins	lb	kg	in	m	
<b>OXYGEN SYSTEM</b>										
Oxygen cylinder (empty) incl. pressure regulator		4110-1133-02-12	Aerox			9.5	4.31	243.7	6.19	
Single outlet manifold, Pax row		4110-1134-1	Aerox			0.22	0.10	111.0	2.82	
Double outlet manifold, Pilot / copilot		4110-400-6	Aerox			0.5	0.23	103.9	2.64	
Double outlet manifold, Pax row		4110-400-6	Aerox			0.5	0.23	111.0	2.82	
Filling block		4110-405-3	Aerox			0.46	0.21	225	5.72	
Pressure transducer		4110-1126	Aerox			0.4	0.18	230.3	5.85	
Push / pull control knob		4110-1127	Aerox			0.9	0.41	169.3	4.3	
Pressure transducer		D54-9035-00-01	ADZ Nagano			0.29	0.13	230.3	5.85	
<b>ENGINE</b>										
Engine	Centurion 3.0	06-7200-K0003()	Continental Aerospace							
Exhaust tubes		D54-7806-11-00()	Diamond Aircraft							
Exhaust tubes		D54-7806-12-00()	Diamond Aircraft							
Exhaust tubes		D54-7806-21-00()	Diamond Aircraft							
Exhaust tubes		D54-7806-22-00()	Diamond Aircraft							

Table 1 - Equipment List

Airplane Serial No.:		Registration:		Date:		Mass		Lever Arm	
Description	Type	Part No.	Manufacturer	S/N	ins	lb	kg	in	m
<b>ENGINE INDICATING</b>									
Engine / Airframe unit	GEA 71B	011-03682-00	Garmin						
<b>PROPELLER</b>									
Propeller		MTV-12-D/210-56	mt-propeller						
Place:		Date:		Signature:					

Table 1 - Equipment List

**07**  
**DESCRIPTION OF THE AIRPLANE AND ITS  
SYSTEMS**

## 07-01 Airframe

### Description

#### 1 Airframe

##### 1 Fuselage

The CFRP fuselage is of semi monocoque molded construction. The center wing is attached to the fuselage with bolts. The two main spars are part of the center wing. The two main spars are CFRP items. The engine compartment in front of the cockpit is separated from the other structure with a firewall. The fire protection on the firewall is a sandwich of a special fire-resistant matting, which is covered by stainless steel cladding.

##### 2 Wings

The wings have a front and rear spar; each wing has a top shell and a bottom shell. The wings, as well as the ailerons and flaps, are made of GFRP/CFRP, and are principally of sandwich construction. An aluminum fuel tank is installed in each of the outer wings.

##### 3 Empennage

The airplane has a 'T' tail of GFRP/CFRP semi monocoque construction. Both the stabilizers have twin spars. Rudder and elevator are of sandwich construction.

# FLIGHT CONTROLS

## 07-02 Flight Controls

### Description

#### 1 Flight Controls

The ailerons, elevator and wing flaps are operated through control rods, while the rudder is controlled by cables. The flaps are electrically operated. Elevator forces can be balanced by a trim tab on the elevator, which is operated by a Bowden cable. Rudder forces can be balanced by a trim tab on the rudder, which is operated electrically by a Bowden cable.



## 07-03 Ailerons

### Description

#### 1 Ailerons

Construction: GFRP/CFRP composite sandwich.

Hinges: There are 4 hinges, which are hinge pins mounted in an aluminum bracket. They are secured in position by a roll pin. The absence of this roll pin can lead to the loss of the hinge pin and a consequent loss of flight safety.

Operation: Each aileron is connected with an aileron control horn to the push rods of the aileron control system. A rod end bearing is screwed into a steel push rod and locked by means of a jam nut which has locking varnish applied to it. Damage to this varnish can indicate a twisting and thus a change to the adjustment. The connection between the rod end bearing and the control horn is a bolt, the nut of which is likewise sealed with locking varnish. The aileron control horn is fully covered by a fairing mounted to the aileron control horn with three screws. The aluminum control horn is attached to the aileron with 3 screws.

## 07-04 Flaps

### Description

#### 1 Flaps

The flaps are a two piece construction. The inner part of the flap is mounted to the center wing and the outer part to the wing. Both parts are connected to each other with a form fit connection.

Construction: GFRP/CFRP composite sandwich.

Hinges: There are 2 hinges and one flaptrack at the outer part and 2 hinges at the inner part of the flap. These hinges are aluminum brackets. They are screwed to wing, center wing and flaps and interconnected at the pivot joints by bolts. All hinges are covered by aerodynamic fairings.

Operation: The outer flaps are connected with two actuation rods, the inner flap with one actuation rod to the push rods of the flap control system. The flap actuation rods are fully covered by fairings mounted to the flap, center wing and wing. In flaps LDG position the flap actuation rods are visible through the gap between wing/center wing and flap and can be inspected by the pilots for loosening interconnection.

The flaps are driven by an electric motor and have 3 settings:

- Cruise (UP), totally retracted
- Take-off (T/O), and
- Landing (LDG).

The flaps are operated by means of a 3-position flap selector switch on the instrument panel. The positions of the switch correspond to the positions of the flaps, the Cruise position of the switch being at the top. If the switch is moved to another position, the flaps continue to travel automatically until they have reached the position selected on the switch. The UP and LDG positions are additionally protected by a limit switch to guard against over-running the end positions.

The electrical flap drive has an automatic circuit breaker which can also be operated manually.

#### 1 Flap Position Indicator

The current flap position is indicated by means of three lights beside the flap selector switch.

When the upper light (green) is illuminated, the flaps are in the Cruise position (UP);

when the center light (white) is illuminated, the flaps are in Take-Off position (T/O);

when the lower light (white) is illuminated, the flaps are in Landing position (LDG).

When two lights are illuminated simultaneously, the flaps are between the two indicated positions. This is the case only when the flaps are in transition.

## 07-05 Rudder

### Description

#### 1 Rudder

Construction: GFRP sandwich.

Hinges: Upper hinge: One bolt.

Lower hinge: Bearing bracket including rudder stops, held by 4 screws to the rear web of the vertical stabilizer. The mating part on the rudder is a bracket which is attached to the rudder by 2 bolts. The upper bolt and nut is accessible to visual inspection.

Operation: Steel cables, the eyes of which are connected to the bracket.

## 07-06 Elevator

### Description

#### 1 Elevator

Construction: GFRP sandwich.

Hinges: 5 hinges.

Operation: Steel pushrods;

The elevator horn and its bearing, as well as the connection to the pushrod, can be visually inspected at the upper end of the rudder. Bolts, secured by crown nuts and split pins are connecting the elevator to the horizontal tail at the other 4 hinges locations. These pivot joints can be inspected from the lower side of the horizontal tail.

## 07-07 Elevator Trim

### Description

#### 1 Elevator Trim

The trim control is a black wheel in the center console to the rear of the power lever. To guard against overrotating, the trim wheel incorporates a friction device. A mark on the wheel shows the take-off (T/O) position.

Turn wheel to the front = trim nose down

Turn wheel to the rear = trim nose up

## 07-08 Rudder Trim

### Description

#### 1 Rudder Trim

The rudder trim control are integrated push buttons on the lower side of the power lever. An indication on the G1000 NXi MFD shows the center position, the bold area and the direction of movement.

Push the right button = right turn / trim to the right

Push the left button = left turn / trim to the left

## 07-09 Rudder Pedal

### Description

#### 1 Electrical Pedal Adjustment

##### NOTE

The pedals may only be adjusted on the ground!

The pedals are adjusted using a rocker switch, located on the outboard sides of the instrument panel. The related circuit breaker is located on the right side of the instrument panel.

##### 1 Forward Adjustment:

To move the pedals forward, depress upper side of switch. When pedals are in correct position, release switch.

##### 2 Rearward Adjustment:

To move the pedals in the rearward direction, depress lower side of switch. When pedals are in correct position, release switch.

##### 3 Locking:

Upon release, the switch moves automatically to the 'power off' position, thus locking the pedals in the present position.

# INSTRUMENT PANEL



## 07-10 Instrument Panel

### Description

#### 1 Instrument Panel

#### CAUTION

DO NOT INADVERTENTLY OPERATE THE FADEC SWITCH WHEN ADJUSTING THE LH INSTRUMENT PANEL VENTILATION NOZZLE. IN CASE OF INADVERTENT SWITCH OPERATION, BRING THE SWITCH BACK TO THE DESIRED POSITION, TYPICALLY AUTO.

Figure 1 shows the typical DA50 C installation position for the equipment. The actual installation may vary due to the approved equipment version.

1	Electric master switch	16	Ventilation nozzles
2	Avionic master switch	17	Circuit breakers
3	Engine master switch	18	Standby attitude module
4	Start button	19	Rudder pedal switches
5	Pitot/Static heat switch	20	USB charging ports
6	Alternator Switches	21	Emergency compass
7	FADEC Test button	22	ELT control unit
8	FADEC Force B switch	23	Primary flight display (PFD)
9	Instrument and flood light rotary buttons	24	Audio amplifier/intercom/marker beacon receiver
10	Light switches	25	Multi function display (MFD)
11	Fuel Transfer rotary button	26	De-Ice control panel (optional)
12	Flap selector switch	27	Autopilot control unit (part of MFD)
13	Landing gear switch	28	Essential Bus Switch
14	Alternate static valve	29	Emergency Fuel pump switch
15	Microphone socket	30	Toggle to test switch for LG / stall warning system

**Table 1 - Major Instruments and Controls**

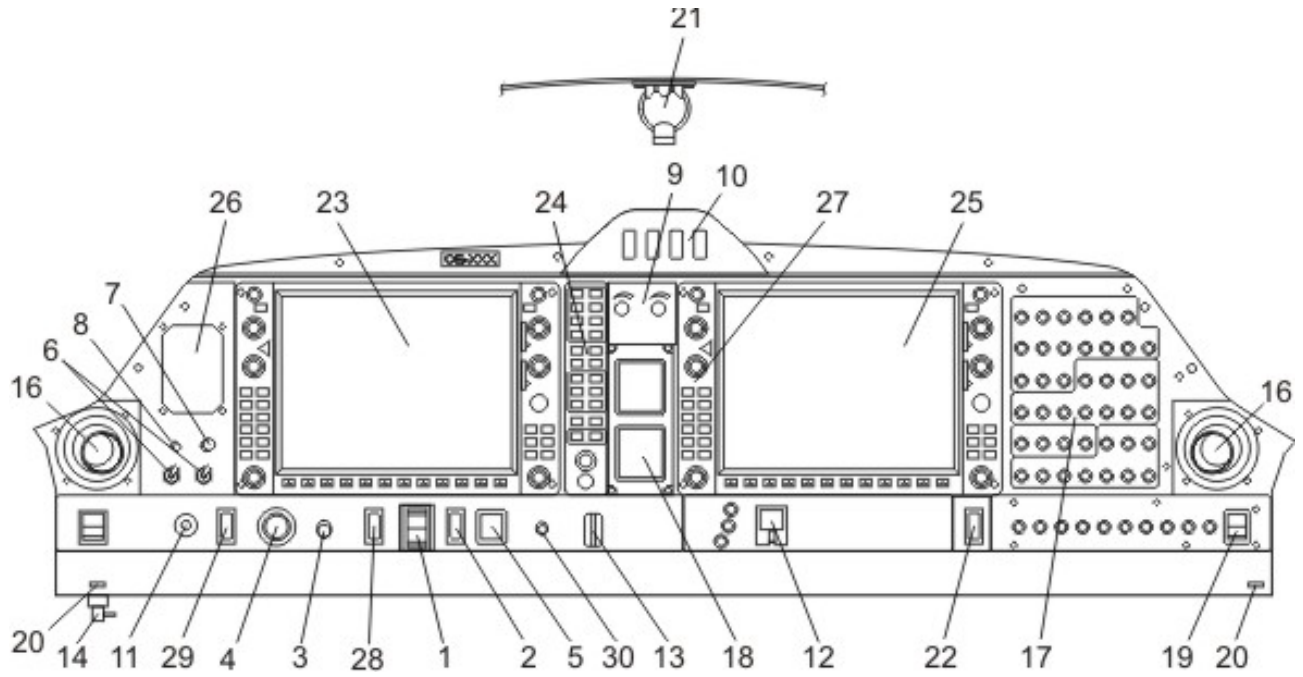

Figure 1 - Instrument Panel

# LANDING GEAR

## 07-11 Landing Gear

### Description

#### 1 Landing Gear System Overview

The landing gear is a fully retractable, hydraulically operated, tricycle landing gear. The nose wheel is able to caster through an angular range of  $\pm 42^\circ$ .

The design and sizing of the landing gear and brake system allows a maximum take-off mass (MTOM) of 1999 kg. The dampers utilize hydraulic fluid as per MIL-PRF-5606 and gaseous nitrogen. All landing gears are equipped with low pressure tires and single wheels with disc brakes. Toe-brake pedals mounted in combination with the rudder pedals hydraulically operate the disc brakes. A parking brake valve allows the brakes to be activated for securing and parking purposes.

The main functions of the landing gear and brake system are to

- Enable adequate manoeuvrability of the airplane on the ground;
- Provide shock absorption during ground taxi and landing operations, e.g. on uneven surfaces;
- Enable rapid airplane deceleration after touch-down through use of high-energy dissipating disc brakes;
- Allow safe parking and mooring of the airplane.

The hydraulic pressure for the landing gear operation is provided by an electrically powered hydraulic pump, which is activated by a pressure switch, when the required pressure is too low. Electrically actuated hydraulic valves, which are operated with the gear selector switch, provide the required hydraulic pressure for the movement of the landing gear. The gear selector switch is located on the instrument panel. The switch must be pulled out before it is moved to UP or DOWN position. Gear extension normally takes 6-10 seconds.

When the landing gear is retracted, the nose landing gear retracts in a rearward movement and the left and right main landing gears retract simultaneously inboard. Hydraulic pressure on the actuators keeps the landing gear in the retracted position. A pressurized gas container acts as an accumulator which keeps the system pressure constant by replacing the volume lost due to the normal actuator leakages. This prevents a permanent starting of the hydraulic pump in flight.

Springs assist the hydraulic system in gear extension and locking the gear in the down position. After the gears are down and the downlock hooks engage, springs maintain force on each hook to keep it locked until it is released by hydraulic pressure.

The three green lights directly next to the landing gear operating switch illuminate to indicate that each gear is in the correct position and locked. If the gear is in neither the full up nor the full down position, a red warning light on the instrument panel illuminates.

Should the power lever be placed in a position below 25% while the landing gear is retracted, a warning horn sounds to alert the pilot that the gear is retracted. Additionally, a CHECK GEAR caution is indicated on the PFD. The same warning appears if the flaps move into position LDG (fully extended) while the gear is retracted.

To test the gear warning system (refer to [04-05 - Pre-Flight Inspection - Cabin Check - Pre-operation procedure](#)) push the test button close by the gear selector switch. The aural gear alert should appear.

#### NOTE

If the aural alert does not appear, an unscheduled maintenance is necessary.

To prevent inadvertent gear retraction on ground, an electric squat switch prevents the hydraulic valve from switching if the master switch is on and the gear extension switch is placed in the UP position.

The landing gear is designed to be manually operated in the event of failure. Since the gear is held in the retracted position by hydraulic pressure, gravity will allow the gear to extend if the system fails for any reason. To extend and lock the gears in the event of failure, it is only necessary to relieve the hydraulic pressure by means of the emergency gear extension lever, which is located under the instrument panel to the left of the center console. Pulling this lever releases the hydraulic pressure and allows the gear to fall free. Before pulling the emergency gear extension lever, place the gear selector switch in the DOWN position.

### **NOTE**

If the emergency gear extension has been pulled due to an emergency, the system has to be checked before pushing the lever in again.

In case of an emergency gear extension the airspeed should be reduced to 102 KIAS. Otherwise the aerodynamic drag on the nose gear delays or prevents a complete extension of the gear. At low OAT and cold soaked aircraft the landing gear extension and retraction, especially emergency extension time is extended.

The pilot can steer the airplane on the ground with the rudder pedals and brakes, depending on taxi speed and desired rate of change in direction. When he pushes the left rudder or brake pedal forward the aircraft and the nose gear turns to the left due to aerodynamic and brake friction forces. When he pushes the right rudder or brake pedal forward the aircraft and the nose gear turns to the right due to aerodynamic and brake friction forces.

A nose gear centering system, attached to the nose gear leg, helps to taxi straightforward. The nose gear is also designed so as to ensure the nose gear is properly centred as soon as it leaves the ground.

---

## 07-12 Hydraulic Gear Extension System Schematic Description

### 1 Hydraulic Gear Extension System Schematic

The landing gear of the DA 50 C is extended with three hydraulic cylinders. The following schematic figures show the system conditions for each operating mode.

In [Figure 1](#) the extension of the landing gear is shown. To reduce the amount of pumped hydraulic fluid during this operation, the return flow is partly led into the feeding flow of the system.

[Figure 2](#) shows the system status, when the landing gear is extended. All hydraulic cylinders are under high pressure.

The operating mode for the retraction of the landing gear is shown in [Figure 3](#). While energizing the right hydraulic valve, the fluid flow in the hydraulic system is started due to different piston areas of the landing gear cylinders although the pressure on both sides of the system is equal.

While the landing gear is retracted, both valves are energized and excessive hydraulic fluid on one side is drained into the tank. This configuration of the system is shown in [Figure 4](#).

For an emergency extension of the landing gear the hydraulic fluid can pass through an emergency extension valve, so that the gear is extended by gravity. The condition of the system is shown in [Figure 5](#).

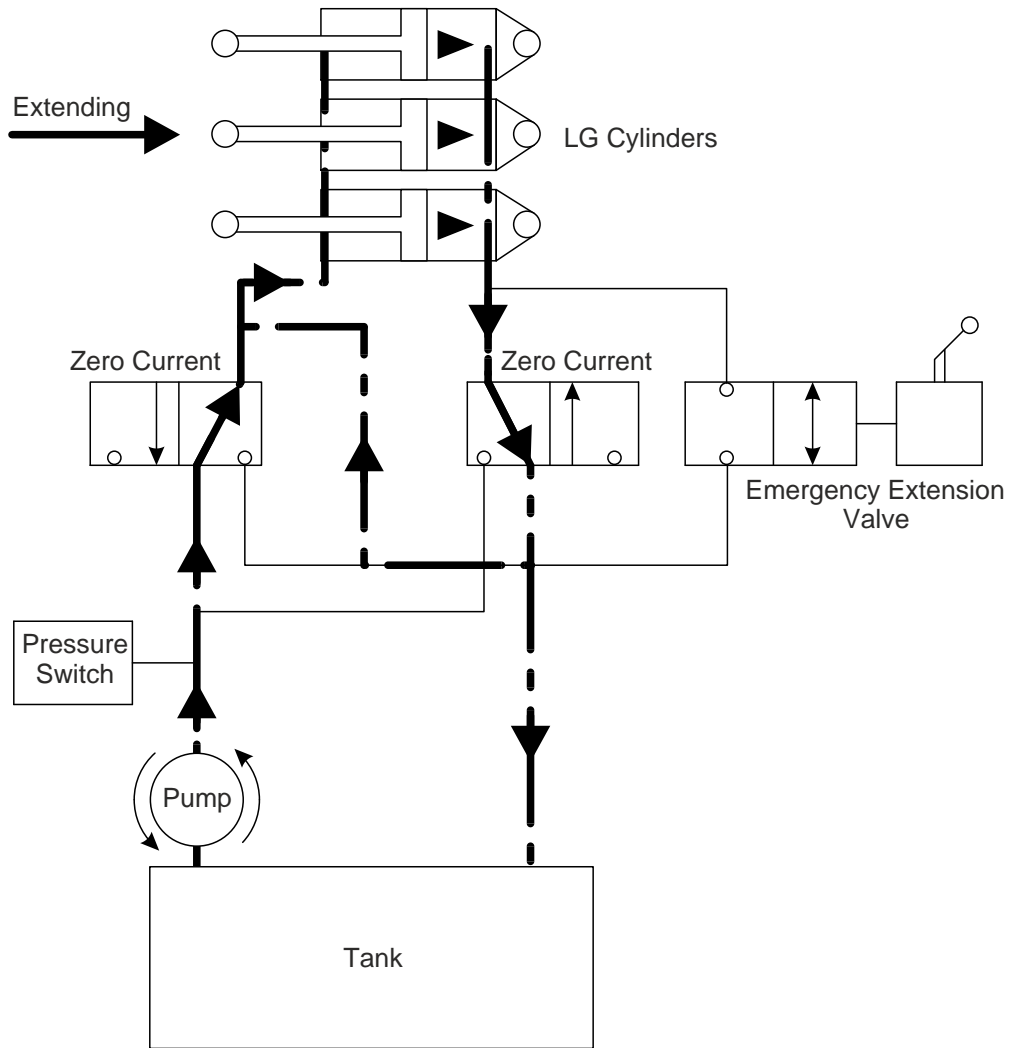

Figure 1 - Extension of the Landing Gear

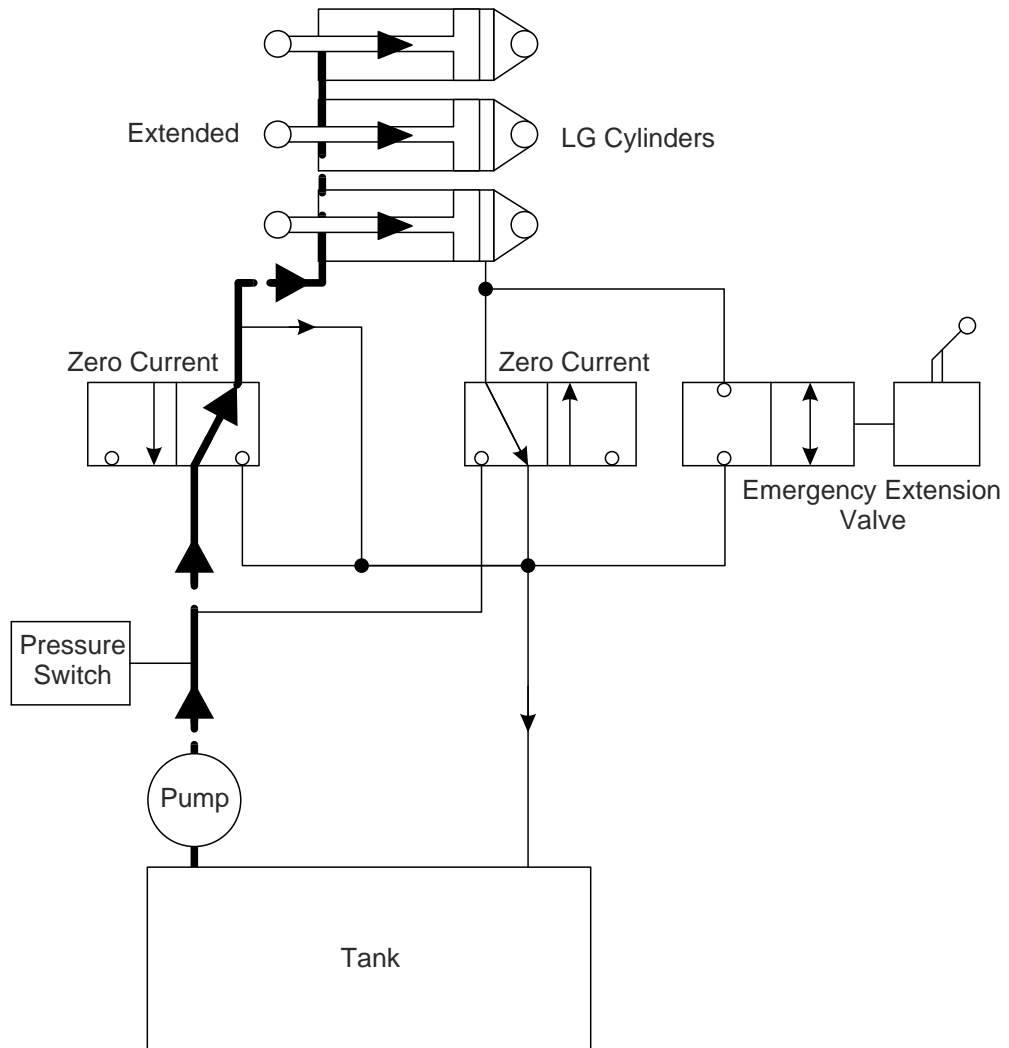

Figure 2 - Landing Gear Extended



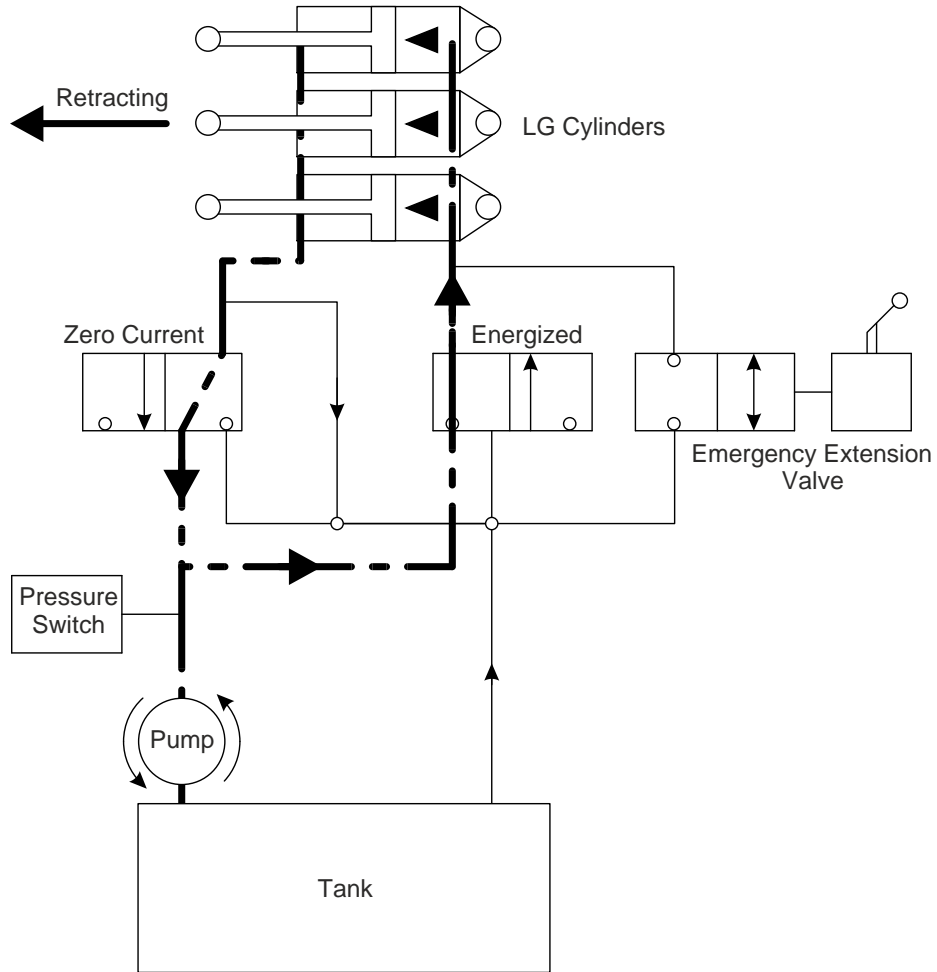

Figure 3 - Retraction of the Landing Gear

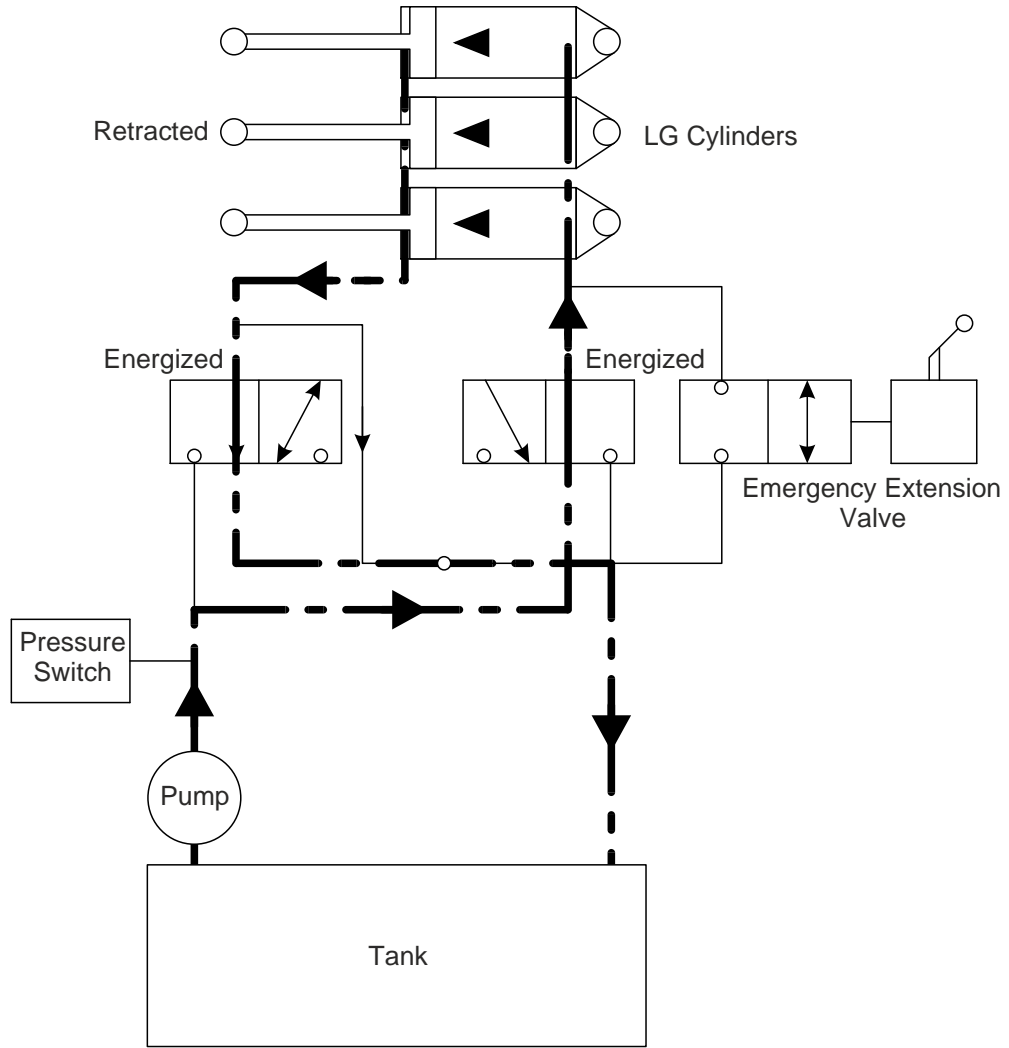

Figure 4 - Landing Gear Retracted

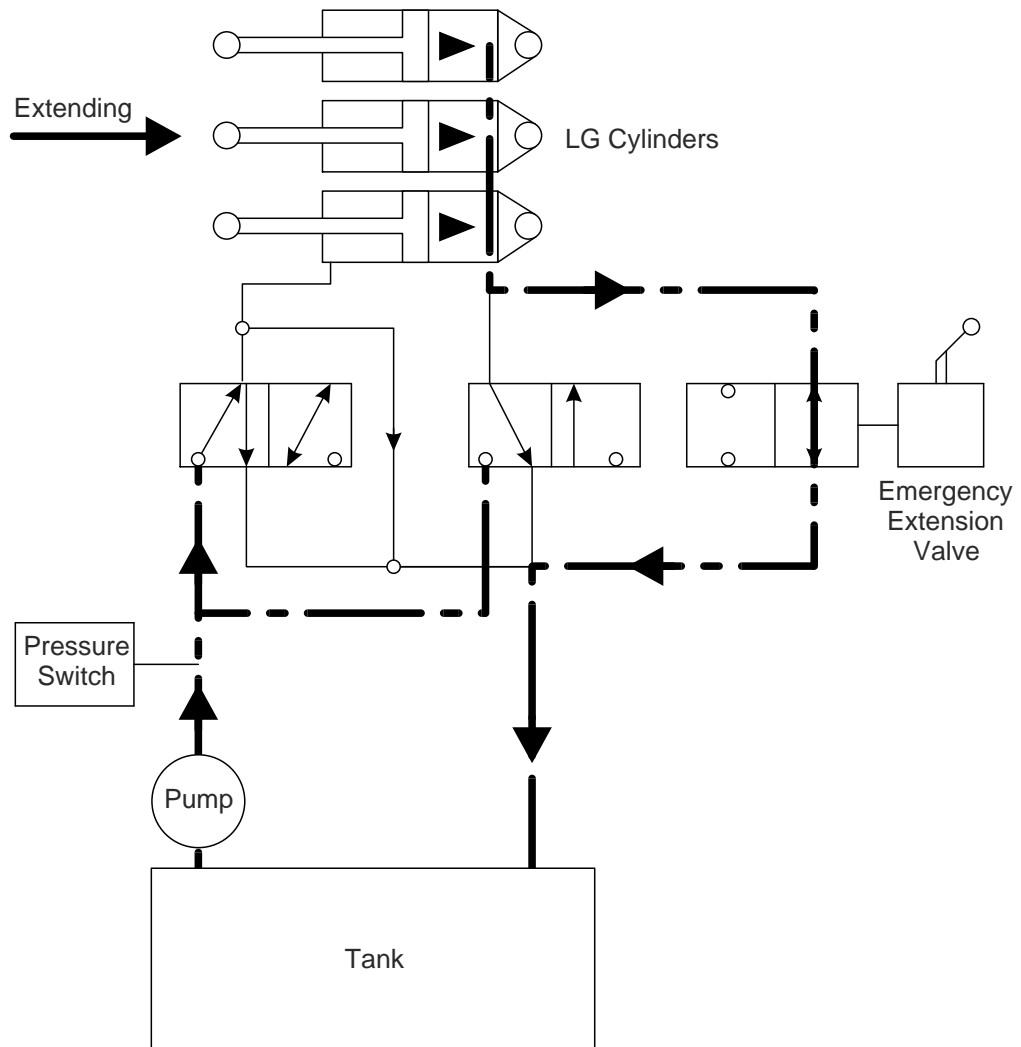

Figure 5 - Emergency Extension of the Landing Gear

## 07-13 Brake System

### Description

#### 1 Brake System

Figure 6 shows the brake system functional diagram.

##### 1 Wheel Brakes

Hydraulically operated disk brakes act on the wheels of the main landing gear. The wheel brakes are individually operated by means of toe pedals.

##### 2 Parking Brake

The lever is located on the small center console under the instrument panel on the left side of the power lever and is in the upper position when the brakes are set. To operate the parking brake, push the toe pedals and then pull the lever upwards until it catches. To release the parking brake, push again on the toe brake pedals, while unlocking the lever and pushing it forward.

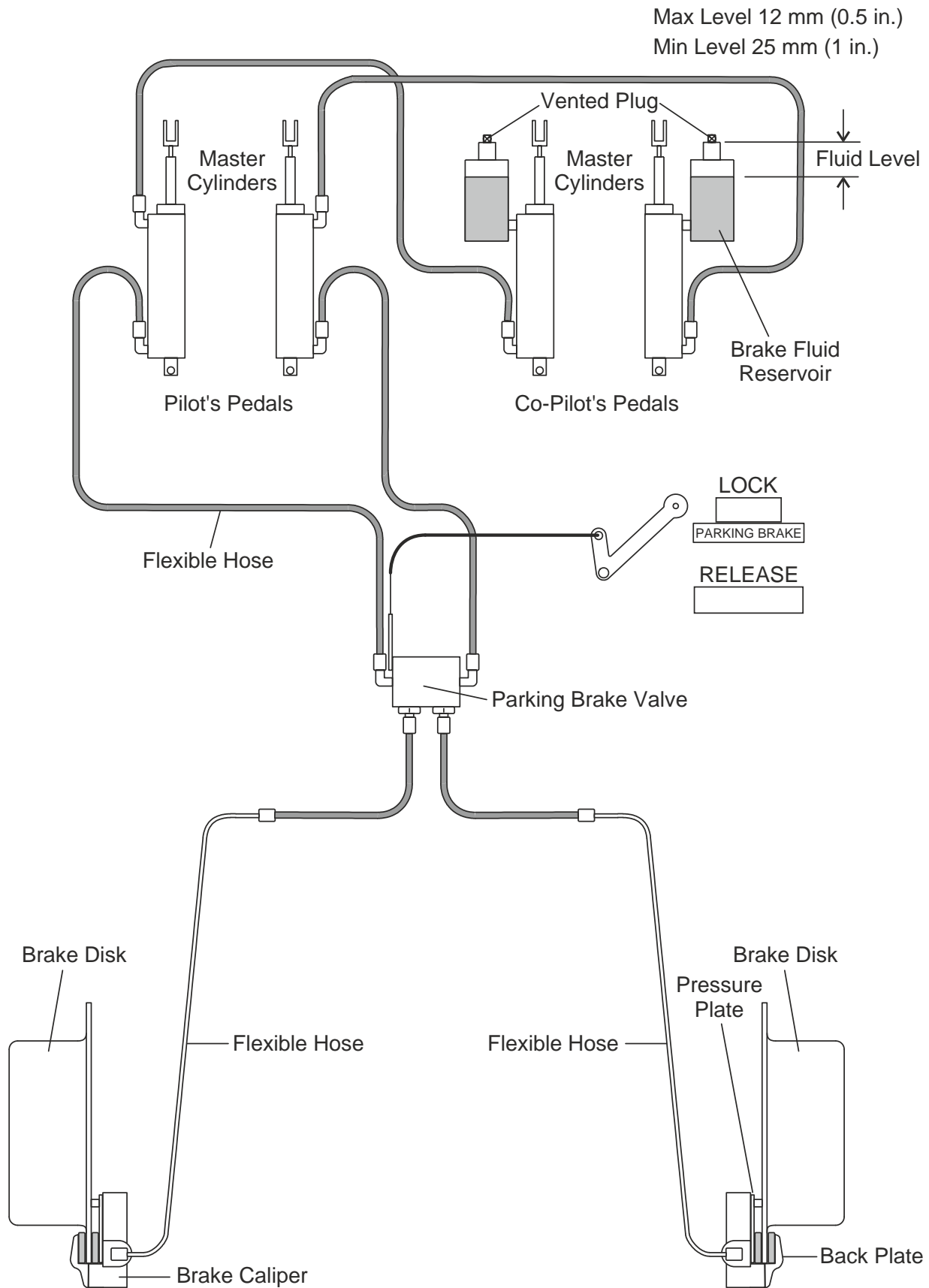

Figure 6 - Brake System Functional Diagram

# SEATS AND SAFETY HARNESSSES

## 07-14 Crew Seat

### Description

#### 1 Seats and Safety Harnesses

##### **CAUTION**

BEFORE ADJUSTING THE ANGLE, LEAN AGAINST THE BACKREST TO COUNTERACT THE SPRING LOAD; OTHERWISE THE BACKREST MAY SLAP FORWARD.

##### **CAUTION**

DO NOT APPLY A LOAD OF MORE THAN 90 DECANEWTONS (202 POUND FORCE) TO THE TOP OF THE BACKREST. OTHERWISE DAMAGE OF THE ADJUSTMENT MECHANISM MAY RESULT.

Figure 1 shows a pilots-seat.

To increase passive safety, the seats are constructed using a carbon fiber/Kevlar hybrid material and GFRP. The seats are removable to allow maintenance and inspection of the underlying controls. Covers on the control sticks prevent loose objects from falling into the area of the controls.

The seats have removable furnishings and are equipped with energy-absorbing foam elements.

The seats are fitted with three-part safety harnesses. The harnesses are fastened by inserting the end of the belts in the belt lock, and are opened by pressing the red release on the belt lock.

The front seats have adjustable backrests installed. The angle of the backrests and the lumbar can be adjusted for best comfort. The backrest release button is situated on the upper side of the seat's side frame. However, during take-off, landing and emergency landing the backrests must be fixed in the upright position designated by a placard on the roll over bar.

The lumbar support can be adjusted by operating the lumbar support lever mounted on the outboard side of the seat pan.

For adjustment press the button and bend the backrest forward or backward to the desired backrest angle. For fixing the position release the button.

In case of a malfunction of the release button the backrest can be moved into the upright position by pulling the backrest (480 N) in flight (FWD) direction.

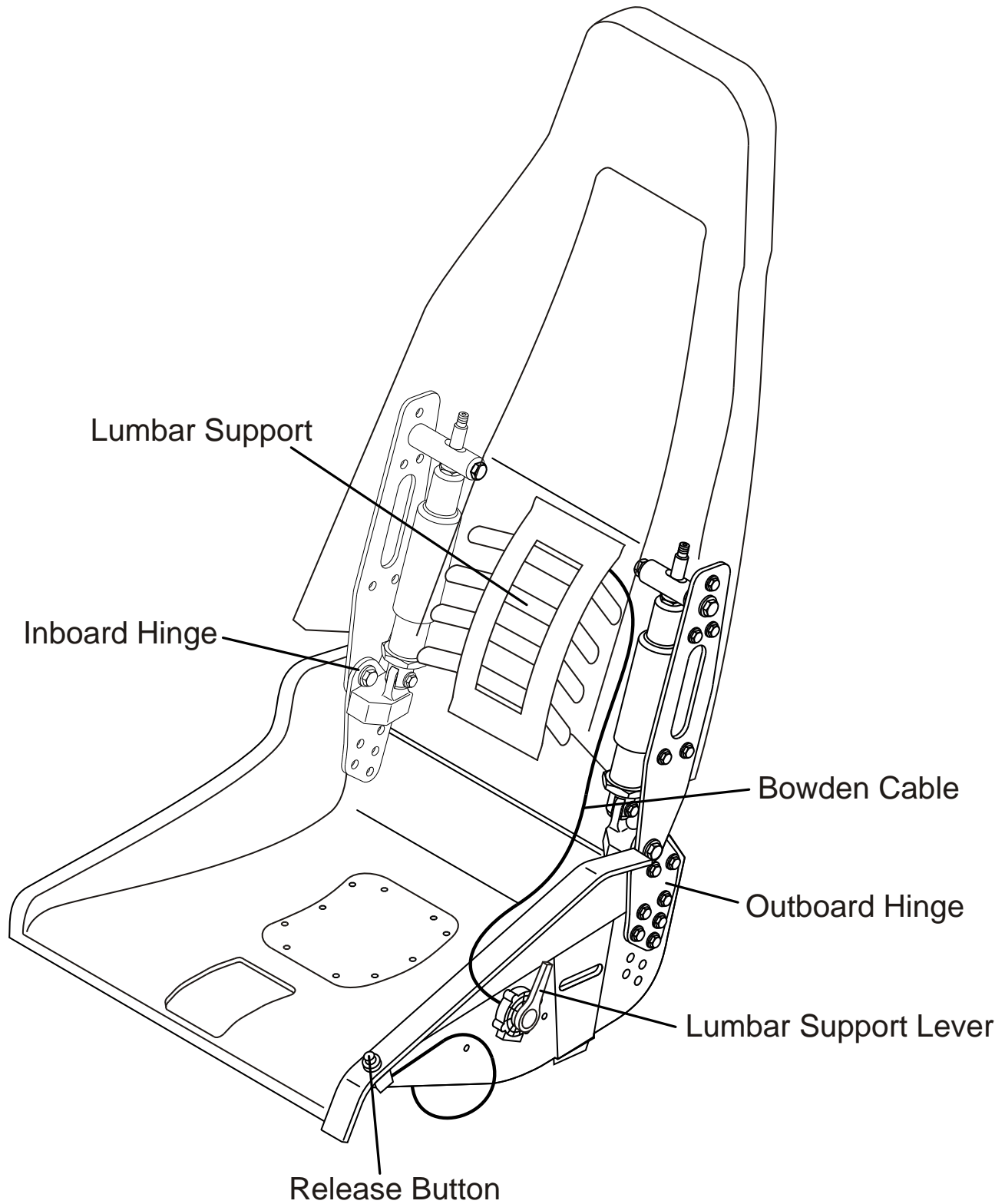

Figure 1 - Pilots Seat



# DOORS AND INTERIOR

## 07-15 LH/RH Pilot Door

### Description

#### 1 LH and RH Pilot Door

The LH and RH pilot doors are closed by pulling down on a handle, which are located between the window and the frame. The doors are locked separately by means of a lever on each frame. On locking, steel bolts lock into mating holes in polyethylene blocks. A gas pressure damper prevents each pilot door from dropping; in strong winds the assemblies must be securely held.

The pilot doors can be blocked by a locking device on the each side near the opening levers by turning the key clockwise. The closed and blocked doors can be opened from inside by pulling the levers inside the opening handle.

A window on each pilot door can be opened for additional ventilation or as an emergency window.

## 07-16 Passenger Door

### Description

#### 1 Passenger Door

#### **WARNING**

**DO NOT BLOCK THE DOOR WITH THE LOCKING KEY BEFORE FLIGHT IN ORDER TO ASSURE EMERGENCY ACCESS FROM OUTSIDE.**

The passenger door is closed in the same way as the pilot doors by pulling down on the handle and locking it with the lever. A gas pressure damper prevents the door from dropping; in strong winds the assembly must be securely held. The passenger door is protected against unintentional opening by an additional lever.

The door can be blocked by a locking device on the left side near the external door opening lever by turning the key clockwise. The closed and blocked door can be opened from inside by pulling the lever inside the opening handle.

## 07-17 Emergency Exit Window

### Description

#### 1 Emergency Exit Window

The emergency exit is integrated in the window structure (composite frame with mechanical system bonded to the window and covered by an interior panel from the inside). The emergency exit window is secured with a pin against unauthorized access from the outside when parked. The pin is marked with a "Remove Before Flight" Streamer and must be removed before operation of the aircraft. The pin shall be stowed in the Pilot's or Co-Pilot's backrest pocket during operation of the aircraft.

Activation of the emergency exit window is done via the red handle at the rear upper corner of the window. The handle is closed by covers (inside and outside) to avoid mishandling. These covers remain installed until the emergency exit must be used. Activation is possible from the inside as well as from the outside after opening the covers.

The activation process is the same from inside and outside:

- Open the cover
- Pull the handle
- Remove the window

The process is also shown on pictogram type placards next to the covers.

As a further option, an egress hammer is easily accessible to the occupants and all windows could be opened by use of this tool in case of blocked emergency exit.

**Emergency Exit Outside View  
(Composite frame shown as transparent)**

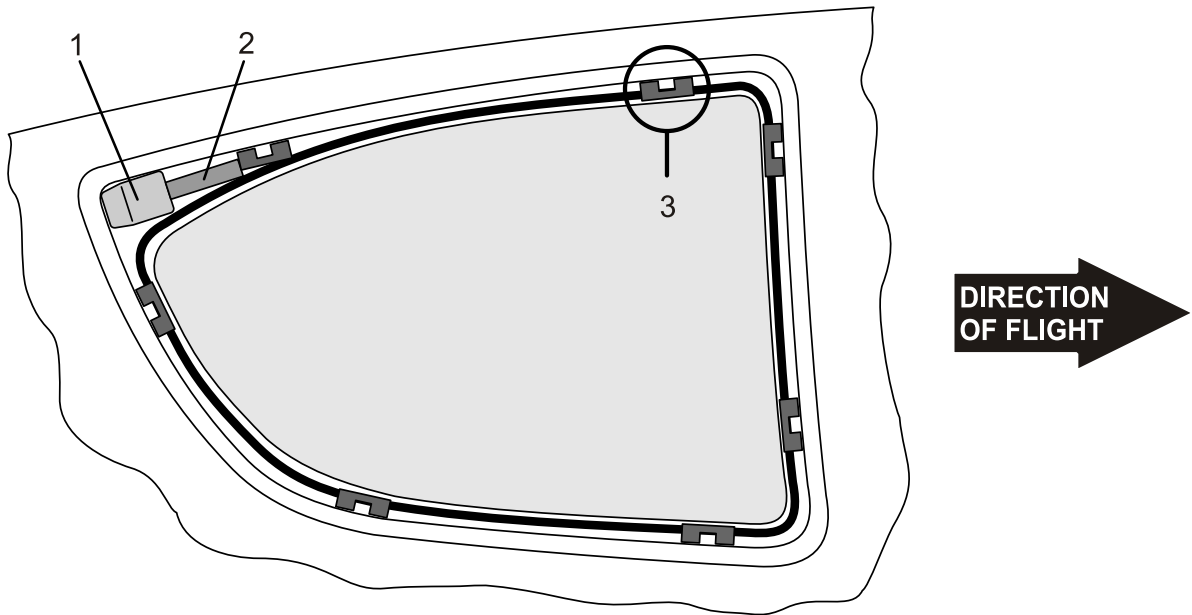

**Emergency Exit Inside View**

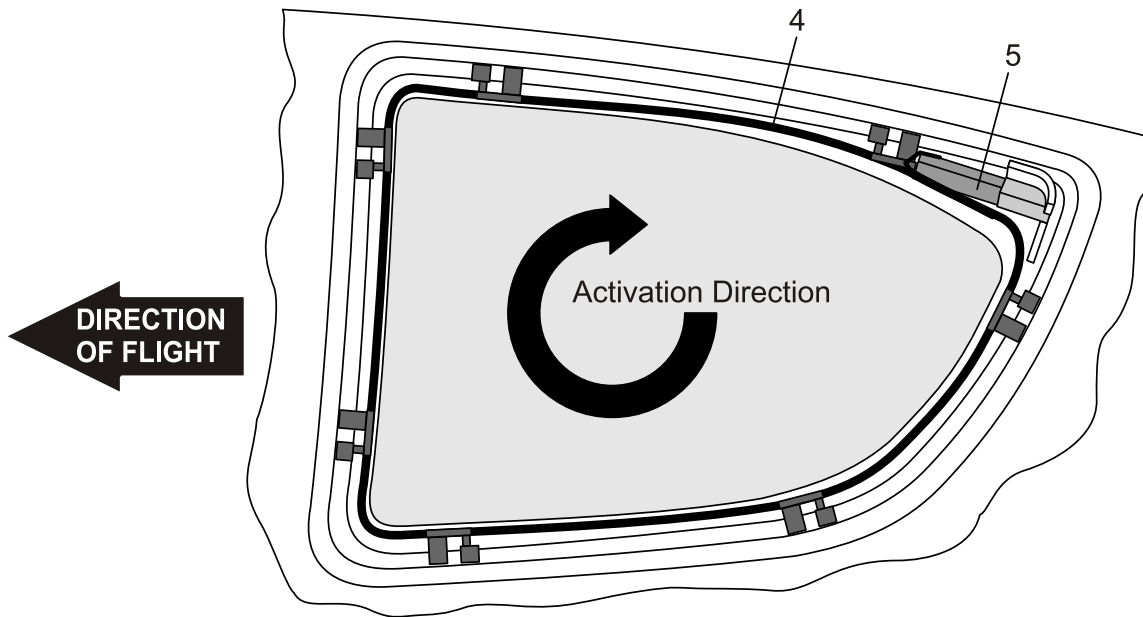

Activation is done via handle at the upper rear window corner; same handle accessible from inside and outside.  
Window locks moved by the single activation rope in the clockwise direction.

**Figure 1 - Emergency Exit Window**

**Legend**

- [1, Fig.1] Activation Handle Cover
- [2, Fig.1] Activation Handle
- [3, Fig.1] Window Attachments (7x)
- [4, Fig.1] Activation Rope
- [5, Fig.1] Activation Handle

## 07-18 Egress Hammer

### Description

#### 1 Egress Hammer

##### **WARNING**

**MAKE SURE NOT TO HARM OTHER PERSONS BY USING THE EGRESS HAMMER.**

##### **WARNING**

**BEWARE OF SHARP EDGES AND FRAGMENTS OF THE BROKEN WINDOW.**

An egress hammer is installed on the floor panel behind the co-pilot's seat.

If the doors can not be opened in case of an emergency use the egress hammer to break through the door windows.

## 07-19 Heating and Ventilation

### Description

#### 1 Heating and Ventilation System

##### CAUTION

DO NOT INADVERTENTLY OPERATE THE FADEC SWITCH WHEN ADJUSTING THE LH INSTRUMENT PANEL VENTILATION NOZZLE. IN CASE OF INADVERTENT SWITCH OPERATION, BRING SWITCH BACK TO THE DESIRED POSITION, TYPICALLY AUTO.

The heating and ventilation system provides the following main functions:

- Supply fresh, unheated air to the flight crew and passengers for cooling purposes, e.g. in a high ambient temperature environment;
- Provide cockpit heating to flight crew and passengers;
- Provide means for removal of fog or frost on the internal portion of the windshield.

A fan can be switched on by a rotary knob located on the ECS panel, to increase the airflow through the system, especially on the ground.

External (unheated) air leading to the fan eye is admitted through a conventional NACA type inlet. The NACA inlet is positioned in an area of the cowling where the airflow is not contaminated by exhaust gases. A "Recirculation valve" installed upstream of the fan is used to isolate the external air supply from the cockpit. Basically, by selecting the recirculation mode, the external air supply is closed and only the air already present in the cabin is allowed to flow through the fan and back to the cabin. This procedure might be useful whenever rapid warm-up of the pilot compartment is necessary or for short time application during flight to prevent entering of contaminated air. That function is operated by a lever on the ECS panel called "CIRCULATING AIR".

##### NOTE

The recirculation mode is intended for short application only.

Downstream of the fan, the air flow is divided into two separate ducts with the aim of providing a heated or an unheated air supply. The incoming air is heated through heat transfer with the engine coolant in a heat exchanger.

The mixing valve installed downstream of the heat exchanger combines the external (or recirculating) air flow and the heated air portion according to the "TEMPERATURE" position in the centre console of the ECS.

An air distributor installed downstream of the mixing valve enables the flight crew to select the following settings/functions:

- Windshield defrost only;
- Windshield defrost and lower (feet area) air nozzles;
- "Feet" and "body" air nozzles.

and is operated by a lever on the ECS panel called "DIRECTION".

Windshield defrost is achieved by 2 nozzles below the glareshield. 4 nozzles are located near the feet of pilot and passengers. 2 nozzles are installed on the LH/RH side of the instrument panel for the comfort of the pilots, 2 nozzles in the rear middle console for the comfort of the passengers. These "body" air



nozzles allow a change of the jet direction of each cone and the jet intensity can be regulated by rotation of the nozzle.

In emergency cases the cabin can be isolated at the main bulkhead by pulling the knob of the ECS shut-off valve. In this case the Recirculating valve must remain in the "FRESH air" position and FAN must be switched off. This will seal the cabin from the exterior at the main bulkhead.

Emergency ventilation can be provided by opening the LH and RH emergency windows.

# POWERPLANT

## 07-20 Engine, General Description

### 1 Engine

The airplane is powered with a Centurion 3.0 engine. The sales name is Continental CD-300.

The CD-300 is a liquid cooled V6-cylinder-four-stroke Diesel engine with double overhead camshafts. The direct fuel-injection engine operates based on the common-rail technology and is turbocharged by two turbochargers. A reduction gear reduces the propeller speed. All RPM figures are published in propeller revolutions. The engine has a dual channel FADEC (Full Authority Digital Engine Control) which controls the fuel injection, the engine RPM and the propeller pitch.

Key specifications are:

Displacement	2987 cm <sup>3</sup>
Compression ratio	15.5
Gear reduction ratio	1.67
Max. take-off power	221 kW at 2340 RPM
Max. continuous power	200 kW at 2300 RPM

## 07-21 Propeller

### Description

#### 1 Propeller

The DA 50 C with the CD 300 Diesel engine has a variable pitch three-bladed propeller, type MTV-12-D/210-56 from mt-Propeller. The blades are made from wood and are covered with GFRP, with an acrylic lacquer painted finish. A stainless-steel sheath protects the outboard leading-edges of the blades from erosion. The inboard section of the leading-edge is protected by a self-adhesive rubber strip (PU tape).”

## 07-22 Propeller Control Description

### 1 Propeller Control

The propeller pitch control system is part of the Engine. The pitch is set by the FADEC via an electro-mechanical control valve. Depending on the power lever setting, the propeller pitch is adjusted such that the most efficient RPM will be obtained. To increase the blade pitch angle, gearbox oil is pumped into the propeller hub. Decreasing the oil pressure leads to a decrease of pitch and a higher RPM.

Depending on the power lever setting the propeller pitch is adjusted such that the required RPM will be obtained as shown in [Figure 1](#).

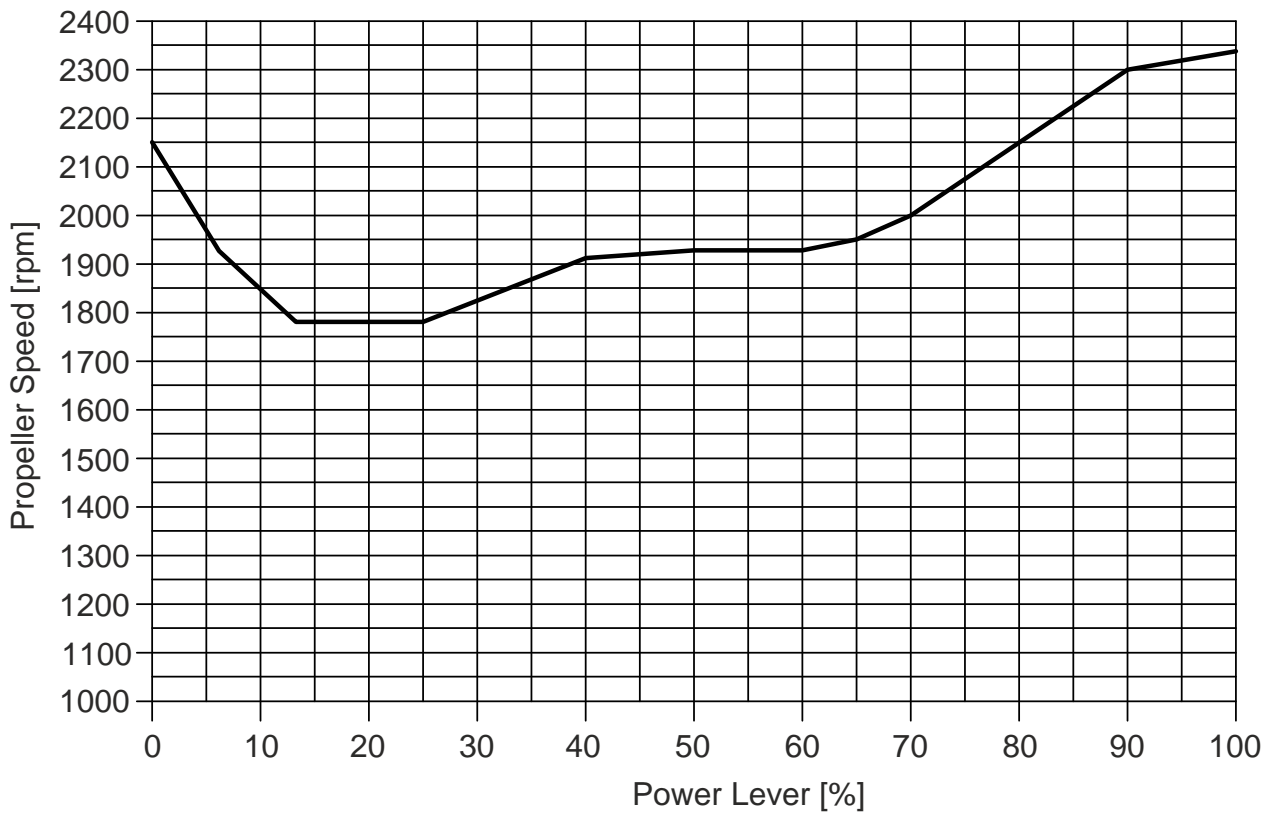

**Figure 1 - Propeller Setpoint Curve**

## 07-23 Engine Operating Controls

### Description

#### 1 Engine Operating Controls

##### 1 POWER LEVER

#### WARNING

IT IS POSSIBLE THAT THE PROPELLER BLADES REMAIN IN THE POSITION OF FINE PITCH IN CASE OF A MALFUNCTION OF THE ENGINE CONTROL UNIT. IN THIS CASE THE REDUCED ENGINE PERFORMANCE SHOULD BE TAKEN INTO CONSIDERATION.

#### WARNING

POWER LEVER OPERATION AFT OF THE FLIGHT IDLE DETENT IS PROHIBITED DURING FLIGHT. SUCH OPERATION MAY LEAD TO TOTAL POWER LOSS.

#### CAUTION

A FAILURE IN THE PROPELLER REGULATING SYSTEM THE RPM IS ADJUSTED USING THE POWER LEVER. EVERY EFFORT HAS TO BE MADE NOT TO EXCEED 2500 RPM.

#### CAUTION

THE POWER LEVER SHOULD BE MOVED SLOWLY, IN ORDER TO AVOID OVER-SPEEDING AND EXCESSIVELY RAPID RPM CHANGES. THE LIGHT WOODEN PROPELLER BLADES PRODUCE MORE RAPID RPM CHANGES THAN METAL BLADES.

#### NOTE

A Ground Idle (GI) function enables the pilot to reduce the power below Flight Idle (FI) at field elevations above 6000 ft for taxi operation.

Engine performance is controlled by a single power lever. The power lever is in the large center console. 'Front' and 'rear' are defined in relation to the direction of flight.

The lever is used to set the desired engine power LOAD (%)

A detent on the power lever avoids inadvertent operation of the ground idle. With a hand on the lever and a distinct force with one or more fingers on the bar on the lower side of the power lever the detent opens.

Lever forward (MAX) = TAKE OFF power

Lever at detent (MIN flight, FI) = Flight Idle

Lever to rear (MIN, GI) = Ground Idle

A ECU controls manifold pressure, injected fuel quantity and propeller speed according to the desired engine power preselected with the power lever. If the power lever is in a low power position - as for a landing approach - while the landing gear is retracted, an aural warning alerts the pilot to the retracted landing gear. Additionally, a CHECK GEAR caution is indicated on the PFD.

A propeller regulating valve is controlled by the FADEC. The propeller control oil circuit is supplied with oil by the gearbox oil pump (also see [07-21 - Propeller - Description](#)).

## 2 ELECT. MASTER

The ELECT. MASTER switch has two positions

- OFF    disconnecting battery power
- ON     connecting battery power to the power distribution system

## 3 ENGINE MASTER

The engine can only be cranked with its ENGINE MASTER switched to ON. When activated, the ENGINE MASTER provides the power supply for the automatic preheat system. To shut down the engine the ENGINE MASTER is switched to OFF.

## 4 START Button

The engine is started by pushing the START button.

## 5 FADEC FORCE B Switch

For normal operation this switch is set to AUTOMATIC. The engine is controlled by ECU A. In case of a failure of the active engine control unit (ECU) there should be an automatic switch-over to the ECU B. If the automatic switch-over fails, switch-over can be done manually by switching to ECU B. This procedure should only be applied in an emergency.

## 6 FADEC TEST Button

There is a FADEC Test button in the instrument panel.

The procedure is possible on the ground only. The test can only be performed with power lever at Ground Idle (GI) and RPM below Approximately 900.

By pushing and holding the button until the end of the procedure, the self-test of the FADEC is started. During the test the FADEC performs a switch from ECU A to ECU B with the propeller cycling. The propeller RPM is monitored automatically by the ECU. When switching from one ECU A to ECU B and back, a slight shake of the engine may occur. After the test, the caution lights must extinguish and the engine must run normal. In flight the FADEC TEST button can be used to reset the ECU caution message by pressing it for more than 2 seconds.

## 07-24 Engine Instruments

### Description

#### 1 Engine Instruments

The engine instruments are displayed on the Garmin G1000 NXi. See [Figure 2](#).

Display when pushing the ENGINE button see [Figure 3](#).

Designation	Indication	Unit
Load %	Available power	%
Oil Pres	Oil pressure	bar
Oil Temp	Engine oil temperature	°C
Coolant Temp	Coolant temperature	°C
Gearbox Temp	Gearbox oil temperature	°C
Rudder Trim	Rudder Trim	--
RPM	Propeller RPM	1/min
Fuel Qty	Fuel quantity	US gal
Fuel Temp	Fuel temperature	°C
Fuel Pres	Fuel pressure	bar
FFlow GPH	Fuel flow	US gal/hr
Gallons Remain	Fuel Remaining	US gal
Gallons Used	Fuel Used	US gal
Endurance	Endurance	hr:min
Range NM	Range	NM
Amps	Ampère	A
Volts	Volts	V
Total Service	Total time in service	hr

**Table 1 - Engine Display**





Figure 2 - G1000 NXi Engine page



Figure 3 - G1000 NXi Full Engine Page

## 07-25 Cooling System

### Description

#### 1 Cooling System

The engine is liquid cooled. The liquid cooling system consists of a short, an external and a bypass cooling circuit. The bypass cooling circuit (cabin heat exchanger) is always active. The short cooling circuit is active at low cooling temperatures. This assures, that a cold engine will warm up quickly. Upon reaching approximately 84 °C (183 °F) coolant temperature the external cooling circuit is activated by a thermostatic valve.

Additionally, a coolant to air heat exchanger is provided for the cabin heat system. The flow through the heat exchanger is independent of the coolant temperature.

A coolant expansion tank allows coolant expansion and pressure adjustment. The coolant system is protected against overpressure by means of a pressure relief valve.

Coolant    50% distilled water  
             50% BASF Glysantin Protect Plus G 48  
                                 Valvoline/Zerex Glysantin G 48

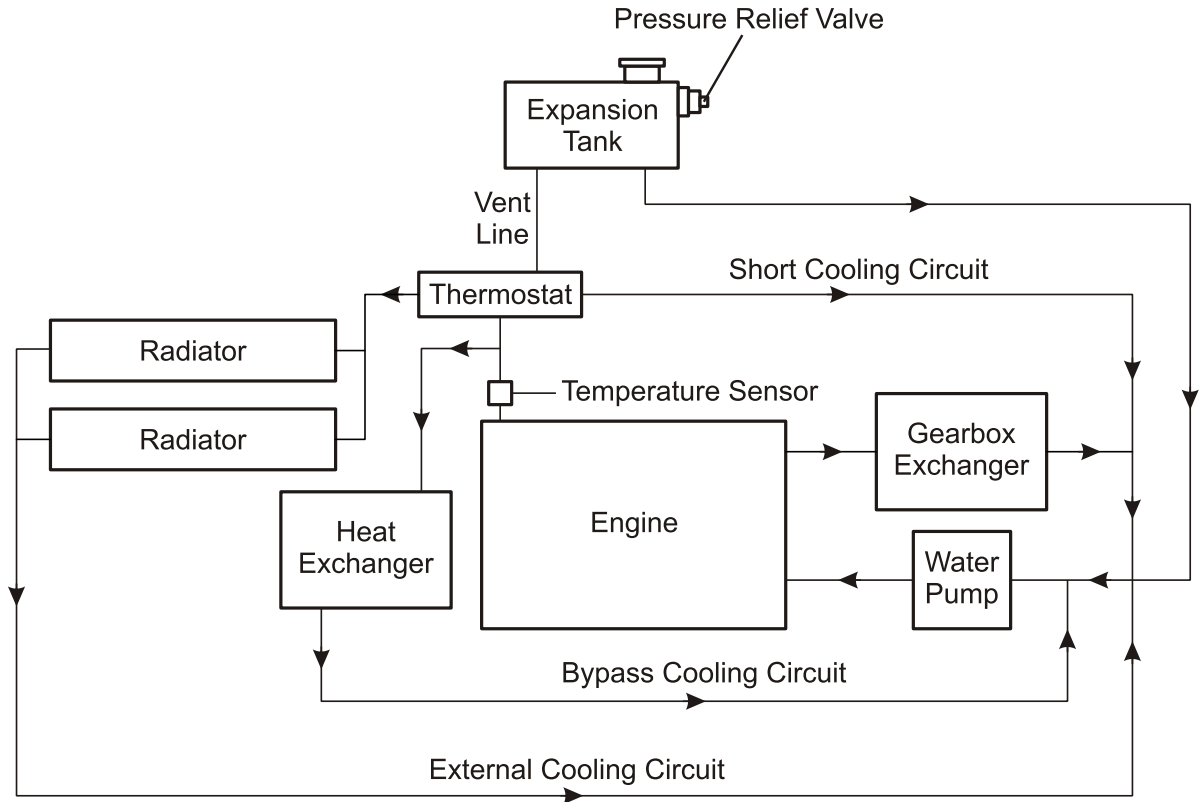

Figure 4 - Liquid Cooling System Schematic Diagram

---

## 07-26 Turbo-Charger System

### Description

#### 1 Turbo-Charger System

The exhaust system contains a manifold which collects exhaust gases from the outlets of the cylinders and feeds them to the turbine of the turbo charger. Behind the turbine the exhaust gases are guided through the LH and RH cowlings to the exterior of the airplane. Excess exhaust gases bypass the turbine. The bypass is controlled by the FADEC through the waste gate valve. A manifold pressure sensor behind the compressor allows the FADEC to calculate the correct position of the waste gate valve. This prevents excessive manifold pressures at low density altitudes. The intake air is compressed in the compressor which is driven by the turbine, and is subsequently cooled down in the intercooler to increase power. Cooling the air increases efficiency through the higher density of the cooler air.

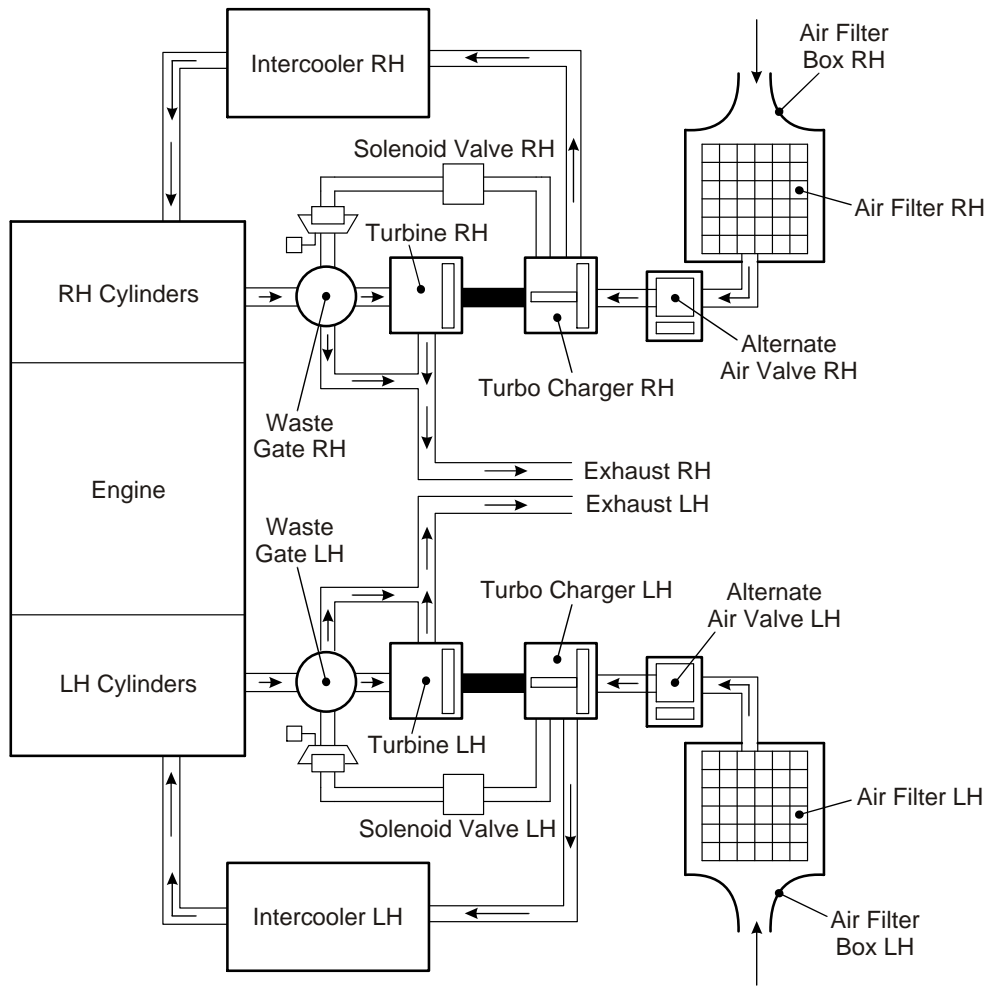

Figure 5 - Turbo-Charger System Schematic

## 07-27 FADEC

### Description

#### 1 FADEC System

The 4-stroke Diesel engine installed in the DA 50 C is electronically controlled by a 32-bit microprocessor engine management system (FADEC). As a result, all aspects of engine operation are based on the load level (lever position) selected by the pilot. For redundancy two independent and identical management systems are installed and continuously monitor each other; their operation depends entirely on aircraft electrical power. In case of failure of one of the systems, the engine control automatically switches to the healthier control unit.

The control unit ensures in normal mode, among other functions, that:

- The correct fuel quantity is metered in accordance with power requested
- The maximum allowable engine power is not exceeded
- Power idle control is achieved
- Turbocharger operation is automatically adjusted and as dictated by such conditions as altitude, ambient temperature and power setting
- Correct propeller pitch and feathering control are achieved

# FUEL SYSTEM



## 07-28 Fuel System

### Description

#### 1 Fuel System

In normal operation fuel is taken out of the LH wing fuel tank via the fuel trap pickup line. From there it passes through the fuel valve and gascolator to the electrically driven low pressure fuel supply pumps to the engine driven low pressure fuel pump (see [Figure 1](#)).

The engine fuel system is part of the engine and is divided into a low pressure circuit and a high pressure circuit. The low pressure circuit comprises a mechanical feed pump which supplies fuel to the injection fuel pump from a fuel fine filter. The mechanical feed pump is mounted on the left cylinder bank, driven by the left cylinder bank camshaft and it is part of the engine. The fuel fine filter is housed in a disposable cartridge. The high pressure pump feeds high pressure fuel in to the common fuel rail, which supplies this to the injectors. Injectors controlled by the FADEC inject the high pressure fuel in to the combustion chamber. Only a part of the fuel flow entering the injection pump is delivered to the combustion chambers. The unused fuel from the injection pump and the fuel leak flow coming back from the injectors is collected in a common fuel return line. The return line feeds the engine return fuel through a loop in the RH fuel tank as well as a fuel cooler back into the main fuel tank, or auxiliary tank, depending on the fuel selector position.

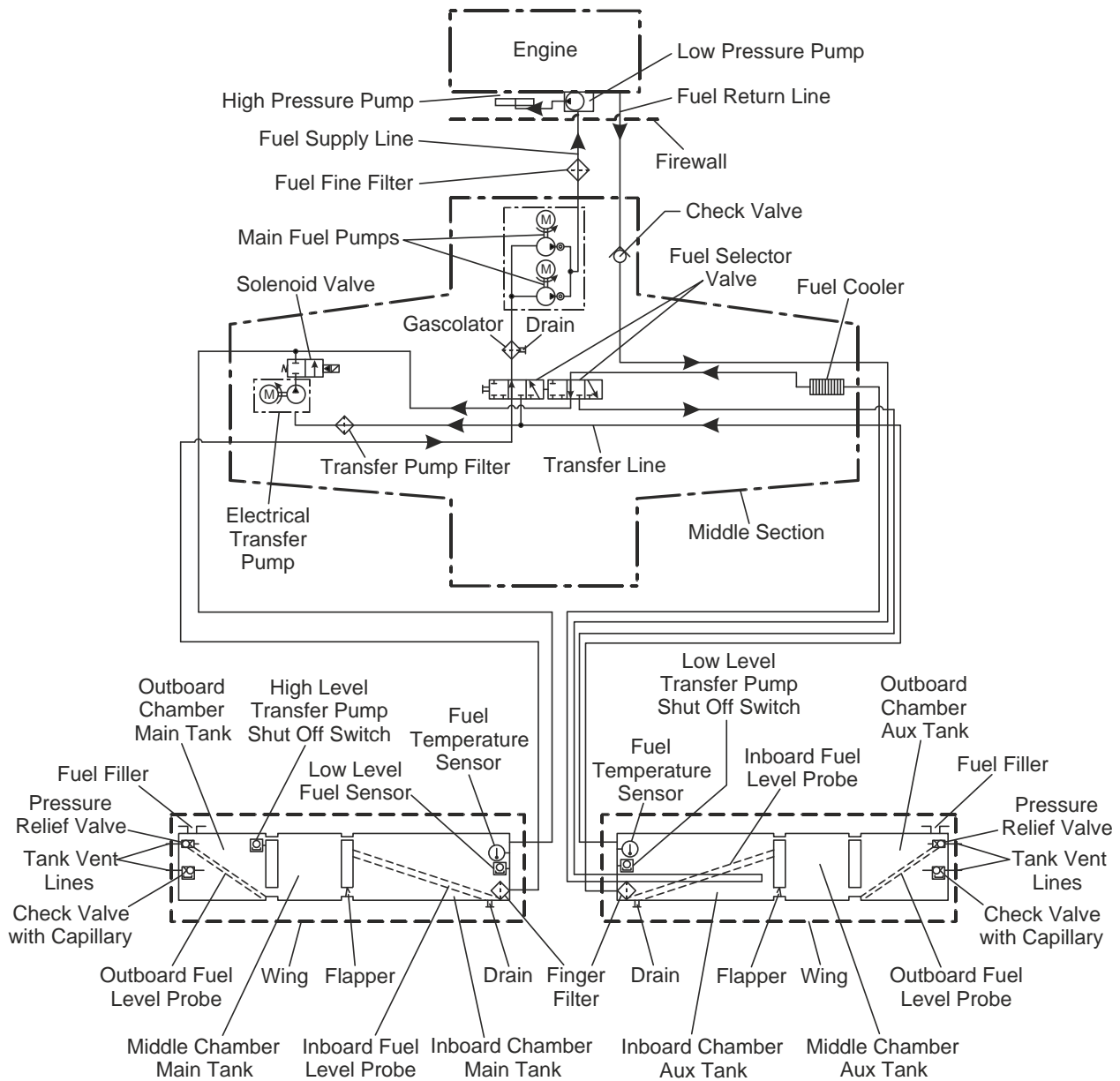

Figure 1 - Fuel System

## 07-29 Fuel Pumps

### Description

#### 1 Fuel Pumps

The feeder pumps to the engine are electrically driven fuel pumps with an internal mechanical adjusted pressure regulating valve (adjusted to 7 psi). The minimum pumping capacity of 180 l/h is provided.

Although the fuel pumps are technically identical, they are bypassing each other and wired up differently. One is the main pump and supplied by the essential bus and the other one is the emergency pump which is supplied by the main bus. The main bus is supplied by the generator 1, in case of its failure, the generator 2 supplies the main bus and the essential bus. If both generators fail the main battery supplies the essential bus.

The main pump is switched with the engine master toggle switch and runs during all ground and flight operation. The emergency pump is controlled by an ON / OFF switch located on the instrument panel.

## 07-30 Fuel Valve

### Description

#### 1 Fuel Valve

The fuel valve handle is located in the personnel compartment centre console, behind the trim wheel. It is connected with a mechanical linkage to the fuel valve. Each of the three positions is secured, through a distinct lifting of the handle that is required to change the position, to avoid inadvertent operation. After closing the shut-off valve it can be easily reopened using the same handle.

This mechanically actuated handle can be placed in 3 positions (see [Figure 2](#) and [Figure 3](#)):

- NORMAL engine supplied from main (LH) fuel tank
- EMERGENCY emergency supply of engine from the auxiliary (RH) fuel tank
- OFF flow to engine is shut off

It is always possible to change between the NORMAL or EMERGENCY tank without passing the OFF position of the valve.

**Normal Fuel Supply and Normal Fuel Transfer**

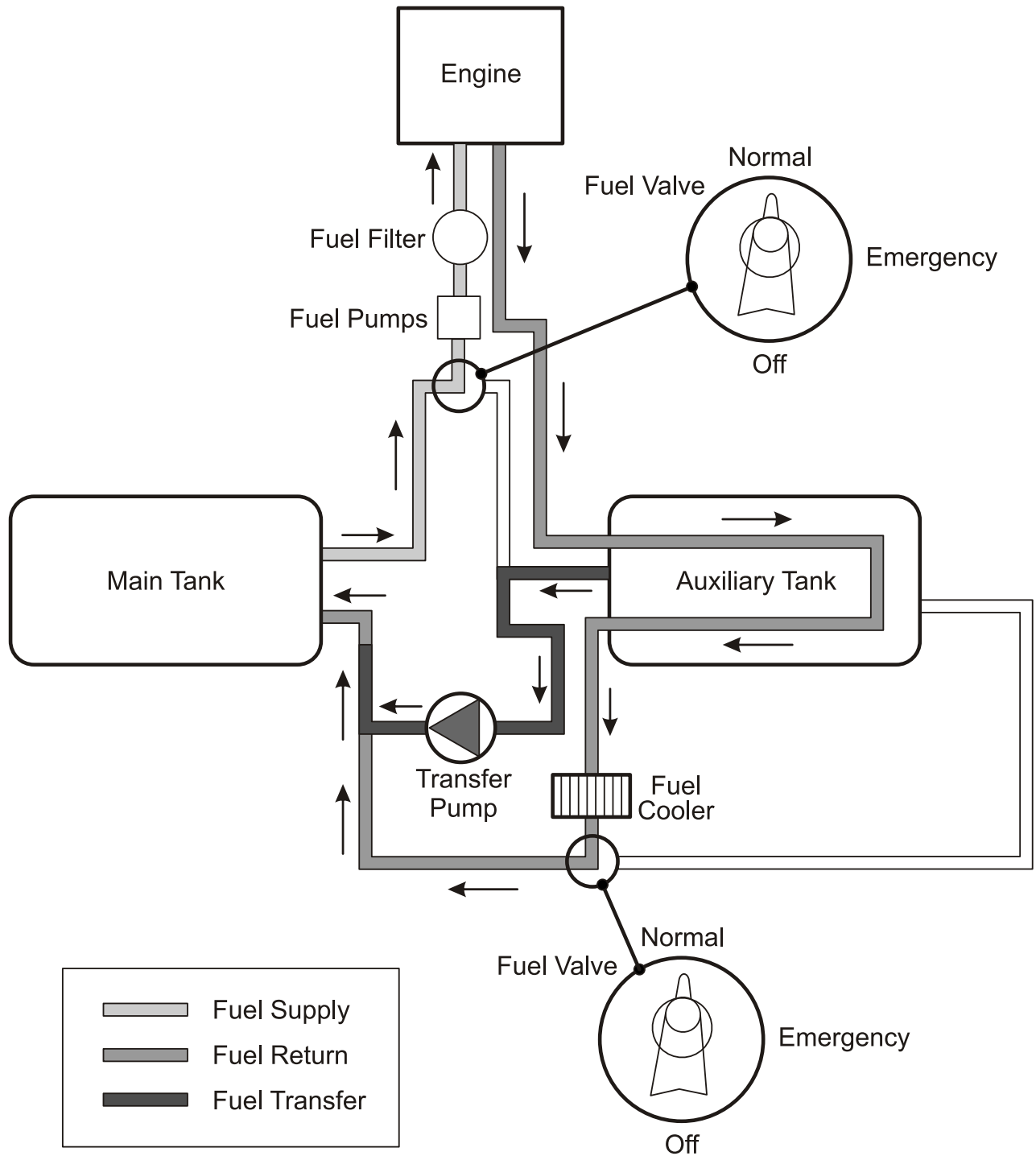

**Figure 2 - Schematic Normal Fuel Supply**

**Emergency Fuel Supply and Emergency Fuel Transfer**

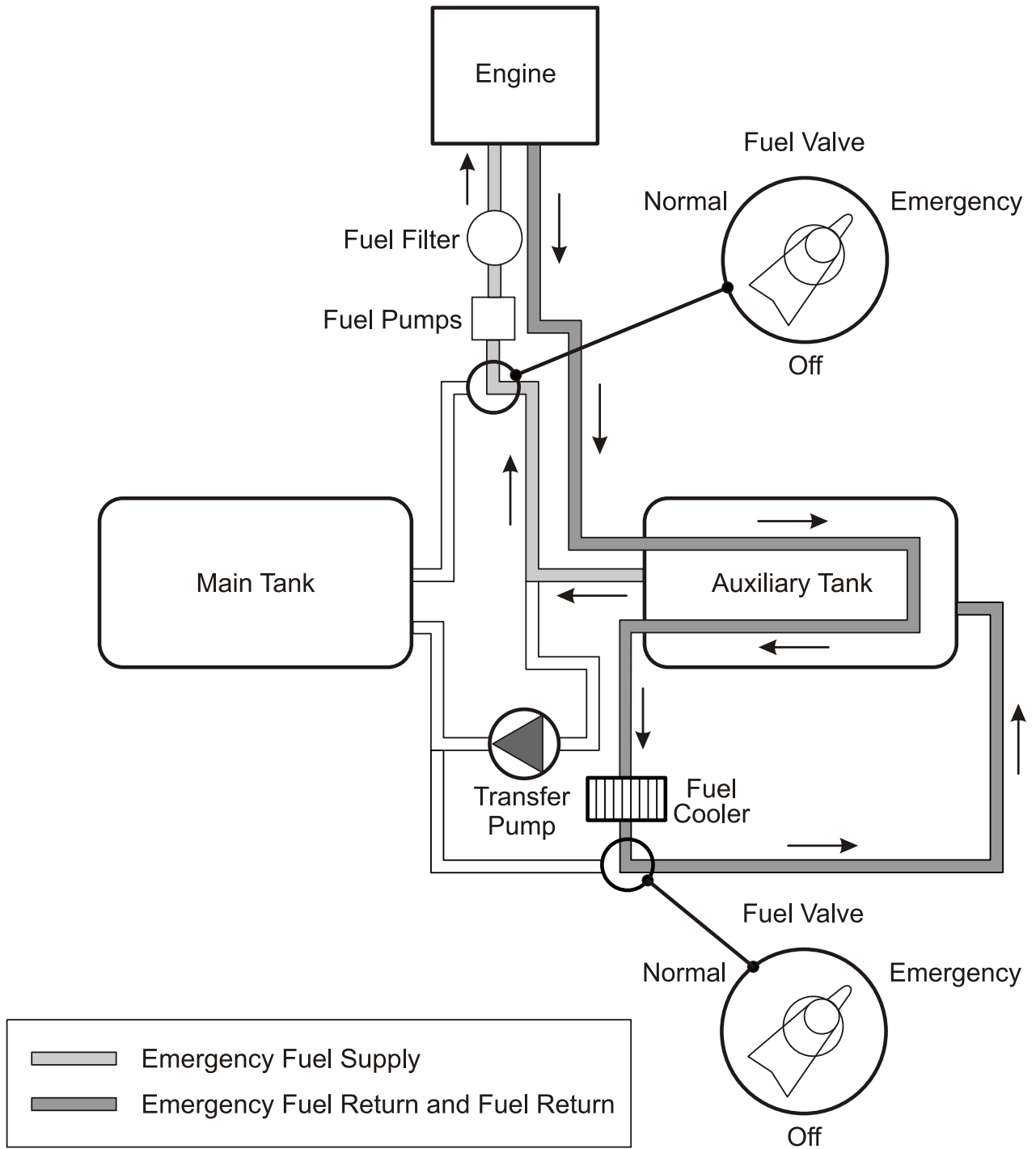

**Figure 3 - Schematic Emergency Fuel Supply**

## 07-31 Fuel Tanks

### Description

#### 1 Fuel Tanks

Both main (LH) and auxiliary (RH) fuel tanks are made of aluminium. The fuel tanks are located in the left and right wing, between the two main spars, and are supported by the wing ribs. Pads made of non-absorbent material are installed to prevent chafing.

Sensors located in the fuel tanks provide low fuel level, fuel temperature and fuel quantity information. The fuel tanks are divided into three fuel chambers. Each fuel tank assembly has a drain for fuel sampling and fuel tank draining. A fuel filler at the outboard section of each fuel tank allows for refuelling of the tanks. Each fuel tank filler connection is marked with the words "Jet A-1" and the permissible fuel designation. As an electrical bonding grounding point exhaust portion of the engine exhaust protruding from each side of the engine nacelle is used during refuelling. To prevent over and under pressure in the fuel tanks a pressure relief as well as a check valve is installed in each fuel tank outboard chamber.

	Main tank (LH)		Aux tank (RH)		Total	
	US gal	Liter	US gal	Liter	US gal	Liter
Total fuel quantity	26.0	98.4	25.5	96.5	51.5	195.0
Unusable fuel	1.0	3.8	1.5	5.7	2.5	9.5
Useable fuel	25.0	94.6	24.0	90.8	49.0	185.5
Max. permissible difference LH/ RH					9.0	35.0

Table 1 - Fuel Tanks

## 07-32 Fuel Level Check Tool

### Description

#### 1 Alternate Means for Fuel Quantity Indication for the Fuel Tank for Ground Use

The alternate means for fuel quantity indication allows the fuel quantity in the tank to be determined on ground. It functions according to the principle of communicating containers. The fuel quantity measuring device has a recess which fits the airfoil of the wing in front of the fuel tank drain, which lies approximately 90 mm (3.5 in) outboard of the center wing. The metal connector is pressed against the drain of the tank. The amount of fuel in the tank can now be read off from the vertical ascending pipe.

For an exact indication, the airplane must stand on level ground and the measuring device must be held vertically.

The fuel indicator includes a protractor for an additional pitch angle measurement. Read and record the pitch angle.

#### 2 Main (LH) and Auxiliary Tank (RH)

Unfold the fuel indicator and center it at the nose of wing. Read the fuel level on the scale and refer to the tables provided in order to determine the exact fuel quantity.

Fuel Quantity Indicator: Pitch Angle Reading					Usable Fuel Quantity	
2°	3°	4°	5°	6°	US gal	Liter
105	90	85	75	65	1	3.8
120	110	105	100	95	2	7.6
130	125	116	108	102	3	11.4
145	140	132	125	115	4	15.1
160	150	143	135	128	5	18.9
170	165	155	148	137	6	22.7
180	168	160	152	145	7	26.5
186	178	170	161	152	8	30.3
198	190	180	174	165	9	34.1
212	205	198	185	175	10	37.9
220	215	210	200	195	11	41.6
240	230	221	212	205	12	45.4
250	245	239	232	225	13	49.2
270	261	252	245	235	14	53.0
280	275	265	260	252	15	56.8
300	292	285	275	265	16	60.6
315	305	298	290	282	17	64.4

Table 1 - Main Tank (LH)



Fuel Quantity Indicator: Pitch Angle Reading					Usable Fuel Quantity	
2°	3°	4°	5°	6°	US gal	Liter
330	320	312	305	290	18	68.1
340	335	325	320	312	19	71.9
357	348	340	330	320	20	75.7
370	362	352	345	338	21	79.5
390	378	367	358	350	22	83.3
402	395	385	377	366	23	87.1
425	415	407	400	380	24	90.8

Table 1 - Main Tank (LH)

Fuel Quantity Indicator: Pitch Angle Reading					Usable Fuel Quantity	
2°	3°	4°	5°	6°	US gal	Liter
105	90	85	75	65	0.5	1.9
120	110	105	100	95	1.5	5.7
130	125	116	108	102	2.5	9.4
145	140	132	125	115	3.5	13.2
160	150	143	135	128	4.5	17.0
170	165	155	148	137	5.5	20.8
180	168	160	152	145	6.5	24.6
186	178	170	161	152	7.5	28.4
198	190	180	174	165	8.5	32.2
212	205	198	185	175	9.5	36.0
220	215	210	200	195	10.5	39.7
240	230	221	212	205	11.5	43.5
250	245	239	232	225	12.5	47.3
270	261	252	245	235	13.5	51.1
280	275	265	260	252	14.5	54.9
300	292	285	275	265	15.5	58.7
315	305	298	290	282	16.5	62.5
330	320	312	305	290	17.5	66.2
340	335	325	320	312	18.5	70.0
357	348	340	330	320	19.5	73.8
370	362	352	345	338	20.5	77.6
390	378	367	358	350	21.5	81.4
402	395	385	377	366	22.5	85.2

Table 2 - Auxiliary Tank (RH)

Fuel Quantity Indicator: Pitch Angle Reading					Usable Fuel Quantity	
2°	3°	4°	5°	6°	US gal	Liter
425	415	407	400	380	23.5	89.0

Table 2 - Auxiliary Tank (RH)

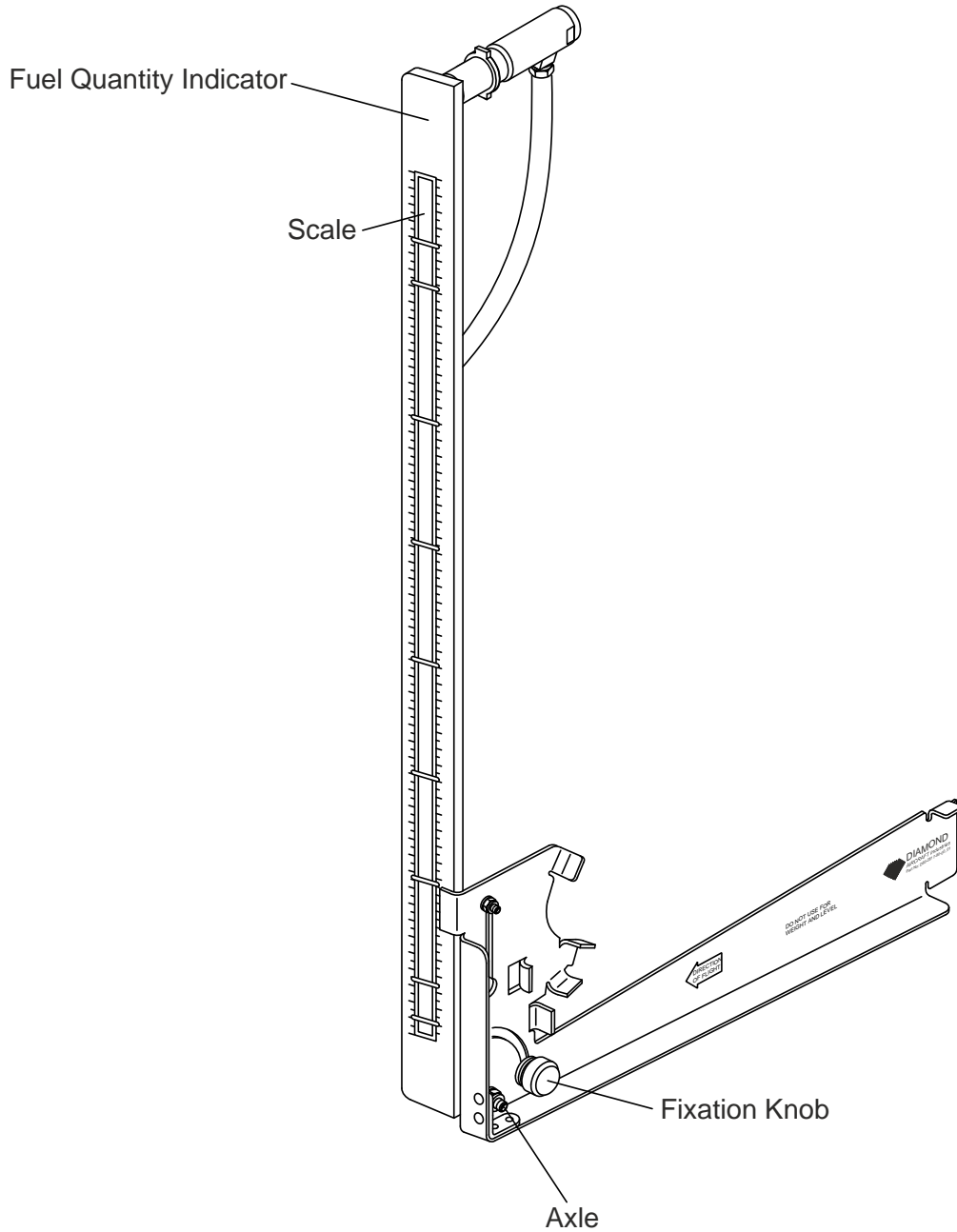

Figure 4 - Fuel Level Check Tool

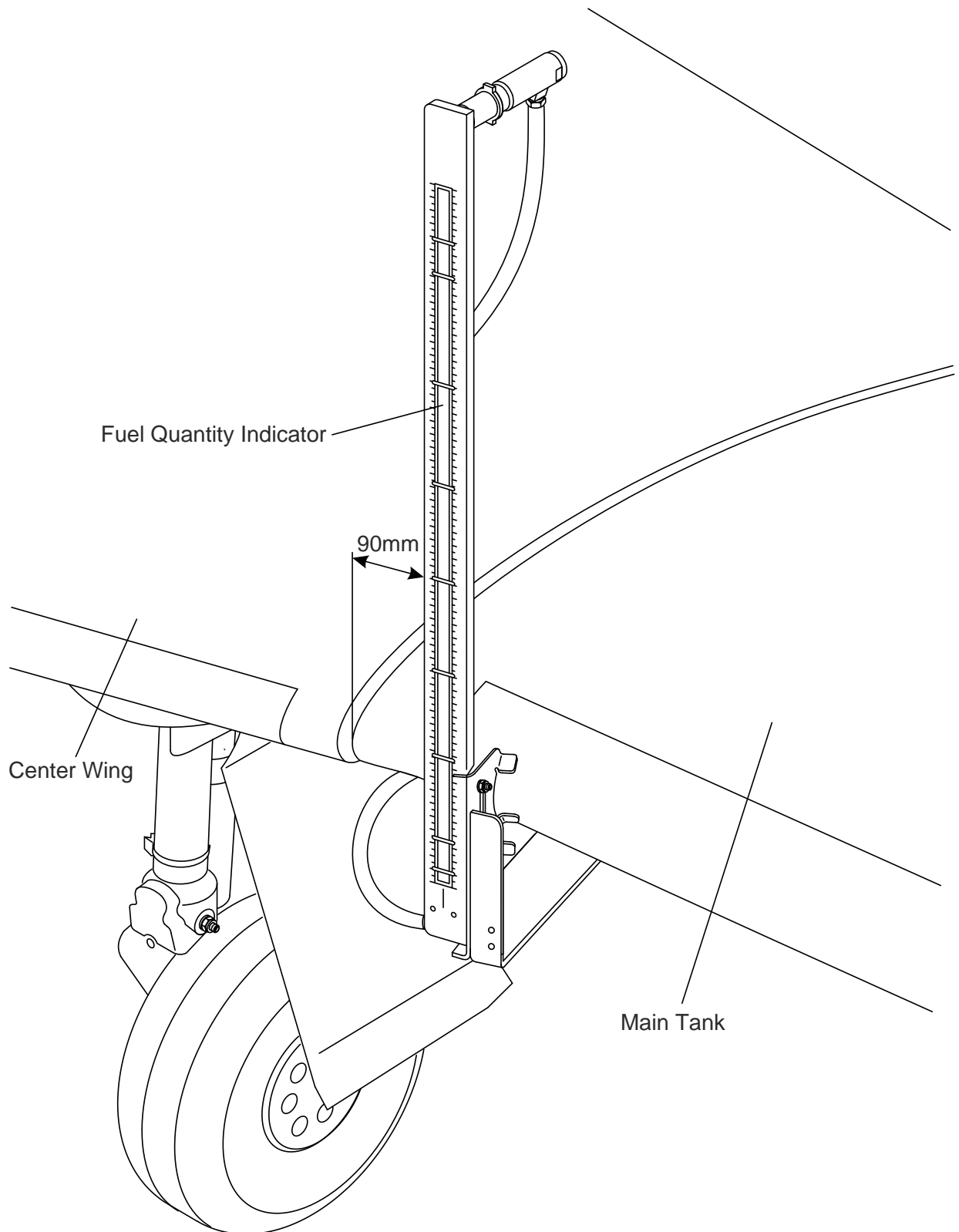

Figure 5 - Fuel Level Check Tool on Wing

# ELECTRICAL SYSTEMS

## 07-33 Electrical System

### Description

## 1 Electrical System

Refer to [Figure 1](#) for the electrical system schematic.

### 1 Power Generation

Power generation is provided by two 70 Ampère alternators which are mounted aft of the engine. The alternators are driven by a flat belt.

The power output line of alternator 1 is connected to the MAIN BUS via the Alternator 1 relay and a 60 Ampère circuit breaker.

The power output line of alternator 2 is not connected to the MAIN BUS during normal operation. Instead it provides power to the air condition system, if installed. When switching the Essential Bus ON, alternator 2 provides power to the MAIN BUS and is disconnected from the air condition system. It is then connected to the MAIN BUS via the alternator 2 relay, the tie relay and a 60 Ampère circuit breaker.

Both alternator output lines also run through current sensors for each alternator, which provide an indication of power being supplied to the electrical system.

In the event of a main battery failure, the field of alternator 1 is energized by two 12V, 1.3Ah sealed lead-acid batteries connected in series, which are installed under the passengers' seats. The field of alternator 2 is energized by two 12V, 7.2Ah sealed lead acid batteries connected in series.

#### 1.1 Alternator Control:

Each alternator has an alternator control unit. It measures the alternator output voltage and controls the current through the alternator field coils via a pulse-width modulated signal. To keep the output voltage stable in all load and speed situations, the alternator field signal is modulated accordingly.

The alternator control unit includes a comprehensive set of diagnostic functions that will warn the operator using a caution message (ALTN 1/2 FAIL) on the G1000 NXi PFD in case of over- or undervoltage as well as a couple of other internal warning levels.

### 2 Storage

Main battery power is stored in a 24 V, 13.6 Ah lead-acid battery mounted behind the engine firewall. The main battery is connected to the BATTERY BUS via the battery relay which is installed in the relay junction box. The battery relay is controlled with the ELECT. MASTER switch which is located on the left-hand side of the instrument panel.

### 3 Distribution

Electrical power is distributed via the HOT BUS, the BATTERY BUS, the MAIN BUS, the ESSENTIAL BUS and the AVIONIC BUS.

**3.1 HOT BUS:**

The HOT BUS is connected to the main battery and cannot be disconnected from the main battery. The HOT BUS provides power to the pilot map/reading light which is protected by its own fuse.

**3.2 BATTERY BUS:**

The BATTERY BUS is connected to the main battery via the battery relay which can be controlled by the ELECT. MASTER switch. The BATTERY BUS provides power to the ESSENTIAL BUS and heavy-duty power to the starter.

**3.3 ESSENTIAL BUS:**

The ESSENTIAL BUS is connected to the BATTERY BUS via a 60 Ampère circuit breaker. It is also connected to the Tie Relay via a 50 Ampère circuit breaker. It provides power to ECU A via a 10 Ampère circuit breaker and to the main fuel pump via a 5 Ampère circuit breaker. The ENGINE MASTER switch must be set to ON to activate ECU A and the main fuel pump.

**3.4 MAIN BUS:**

The MAIN BUS is connected to the Tie Relay via a 50 Ampère circuit breaker. Also, it is connected to the power output of Alternator 1 and 2 each via a 60 Ampère circuit breaker. The MAIN BUS provides power to the AVIONIC BUS via the avionics master relay. The AVIONIC MASTER switch must be set to ON to connect the MAIN BUS to the AVIONIC BUS. Also, it provides power to ECU B via a 10 Ampère circuit breaker and to the emergency fuel pump via a 5 Ampère circuit breaker. The ENGINE MASTER switch must be set to ON to activate ECU B. To activate the emergency fuel pump, the EMERG. FUEL PUMP switch must be set to ON.

**4 Consumers**

The individual consumers (e.g. radio, position lights, etc.) are connected to the appropriate bus via automatic circuit breakers.

Designations and abbreviations used to identify the circuit breakers are explained in Section ACRONYMS – Designation of the Circuit Breakers on the Instrument Panel.

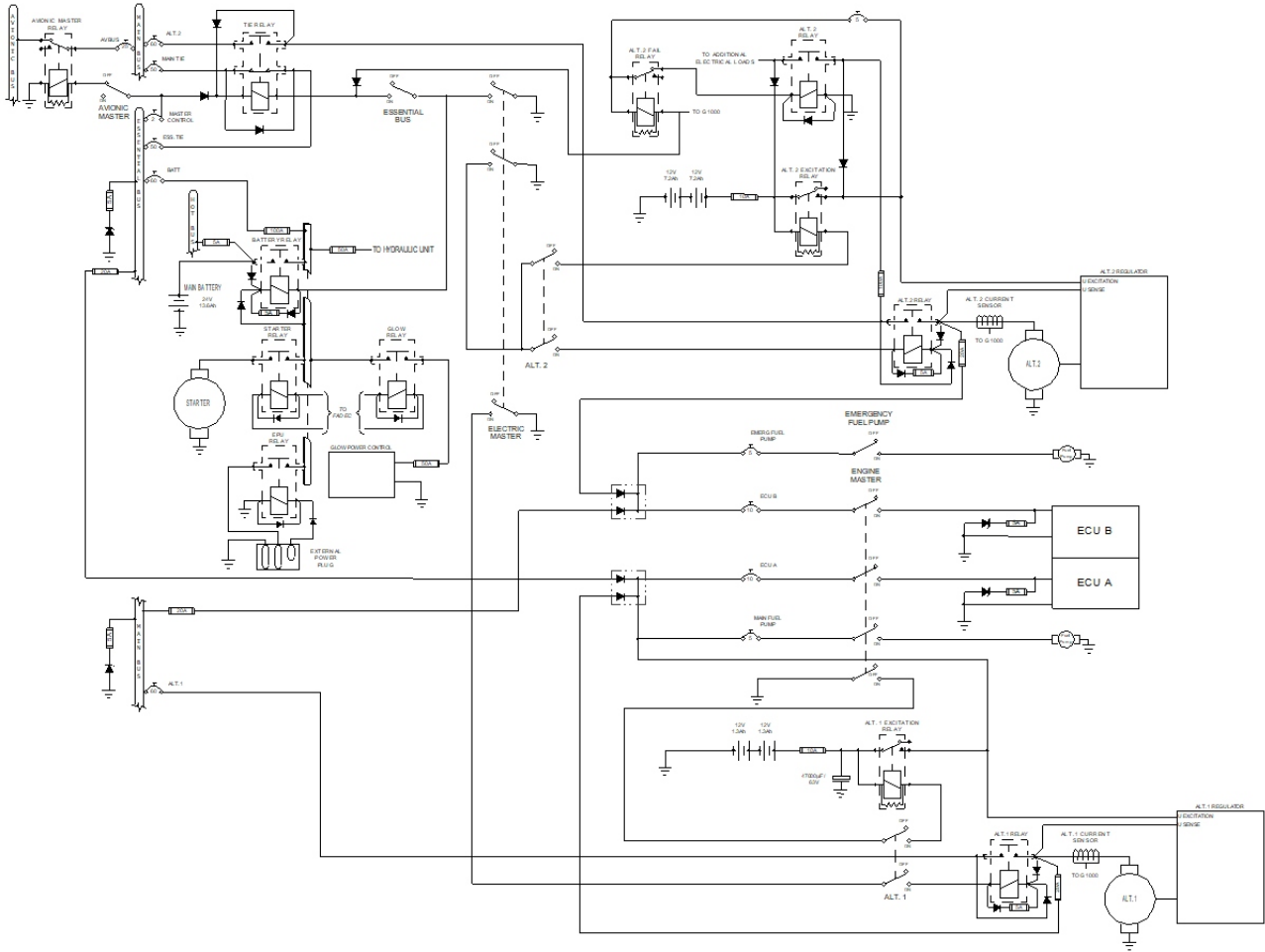

Figure 1 - Electrical System



## 07-34 Standby Attitude Module

### Description

#### 1 Mid Continent MD302 Standby Attitude Module

The Mid Continent MD302 Standby Attitude Module is a self-contained situational awareness instrument that provides airplane attitude, altitude, airspeed and slip indication.

The Standby Attitude Module consists of two separate LCD displays. The upper display serves as artificial horizon and the lower display as airspeed indicator and altimeter. The user interface of the Standby Attitude Module allows for simple, intuitive operation using a single push-and-turn control knob.

Refer to the Mid Continent MD302 Standby Attitude Module Pilot's Guide, P/N 9017846 in the latest effective issue for more information.

The MD302 Standby Attitude Module is not connected to an external ARINC 429 source (Garmin G1000 NXi), thus heading information and automatic BARO synchronization is not available in the DA 50 C.

## 07-35 Crew Alerting System (CAS)

### Description

#### 1 Crew Alerting System (CAS)

The G1000 NXi crew alerting system (CAS) is designed to provide visual and aural alerts to the flight crew. Alerts are divided into three levels as follows:

- **WARNING**
- **CAUTION**
- **ADVISORY**

Crew alerts will appear in the alerts window on the PFD. In this window, warnings will appear at the top, followed by cautions and advisories, respectively. Within the criticality levels, messages will appear from newest (top) to oldest (bottom). At the low right corner of the display, there is a MSG (message) soft key. The MSG key provides two functions in the CAS:

- Pressing the MSG key acknowledges a new master warning/caution/advisory indication.
- An additional MSG key press with no master alert indication active will open a popup auxiliary flight display (AFD) page that contains information for all active alerts.

This structure allows the crew to scroll through all system alerts if the alerts window overflows. This approach displays the most critical alerts close to the pilot's primary field of view at all times, with the option of allowing lower criticality alerts to overflow and be accessible from the pop-up AFD page/window.

Level	Text Color	Importance	Audible Tone
Warning	Red	May require immediate corrective action	Warning chime tone which repeats without delay until acknowledged by the crew
Caution	Yellow	May require future corrective action	Single warning chime tone
Annunciation Advisory	White		None
Message Advisory <sup>1</sup>	White		None
Safe Operation Annunciation	Green	Lowest	None

<sup>1</sup> Note that Message Advisory alerts are posted in the ALERTS window but not in the Annunciation window.

Table 1 - Alert Levels

### 1 Warning Alerts on the G1000 NXi

Refer to [03-04 - Airplane related G1000 Warning Messages - Emergency operation procedure](#) for warning alerts on the G1000 NXi.

### 2 Caution Alerts on the G1000 NXi

Refer to [03A-01 - Airplane related G1000 Caution Messages - Emergency operation procedure](#) for warning alerts on the G1000 NXi.

### 3 Annunciation Advisory Alerts on the G1000 NXi

Annunciation	Condition
<b>GLOW ON</b>	The annunciation is active when the engine glow plugs are powered.
<b>FUEL XFER</b>	The annunciation is active when the fuel transfer from auxiliary to main tank is in progress.

**Table 2 - Annunciation Advisory Alerts on the G1000 NXi**

### 4 Message Advisory Alerts on the G1000 NXi

Annunciation	Condition
<b>PFD FAN FAIL</b>	The annunciation is active when the PFD cooling fan is inoperative.
<b>MFD FAN FAIL</b>	The annunciation is active when the MFD cooling fan is inoperative.
<b>GIA FAN FAIL</b>	The annunciation is active when the GIA cooling fan is inoperative.

**Table 3 - Message Advisory Alerts on the G1000 NXi**

# GARMIN G1000 NXI

## 07-36 Garmin G1000 NXi Integrated Avionics System

### Description

#### 1 Garmin G1000 NXi Integrated Avionics System

The Garmin G1000 NXi is a fully integrated flight, engine, communication, navigation and surveillance instrumentation system. This integrated avionics system consists of a primary flight display (PFD), a multi-function display (MFD), an audio panel, an attitude and heading reference system (AHRS), an air data computer (ADC) and the sensors and computers to process flight and engine information for display to the pilot. The system contains dual GPS receivers, dual VOR/ILS receivers, dual VHF communications transceivers, a transponder, and an integrated annunciation system to alert the pilot of certain abnormal conditions.

A remote avionic box is located in the rear fuselage. A push-to-talk (PTT) button for the COM portion of the G1000 NXi is mounted on the end of each control stick. There are connection facilities for up to 5 headsets. The connections for the pilot, copilot and passenger row are located between the pilot's and copilot's seat.

Refer to the Garmin G1000 NXi Cockpit Reference Guide and Garmin G1000 NXi Pilot's Guide for the Diamond DA 50 C for complete descriptions of the G1000 NXi system and operating procedures.

#### **NOTE**

Near the DME ground station, it can happen under certain adverse conditions that the Bendix/King KN 63 DME loses the direct signal from the ground station and locks onto an "echo". This will result in an inaccurate indication of the distance.

#### **NOTE**

During retraction and extension of the landing gear the ADF-indication may be inaccurate.

## 07-37 Primary Flight Display (PFD)

### Description

#### 1 Primary Flight Display (PFD)

The primary flight display (PFD [Figure 1](#)) typically displays airspeed, attitude, altitude, and heading information in a traditional format. Slip information is shown as a trapezoid under the bank pointer. One width of the trapezoid is equal to a one ball width slip. Rate of turn information is shown on the scale above the compass rose; full scale deflection is equal to a standard rate turn. The following controls are available on the PFD (clockwise from top right):

- Communications frequency volume and squelch knob
- Communications frequency set knobs
- Communications frequency transfer button
- Altimeter setting knob (baro set)
- Course knob
- Map range knob and cursor control
- FMS control buttons and knob
- PFD softkey buttons, including master warning/caution acknowledgment
- Altitude reference set knob
- Heading bug control
- Navigation frequency transfer button
- Navigation frequency set knobs
- Navigation frequency volume and identifier knob

The PFD displays the crew alerting (annunciator) system. When a warning or caution message is received, a warning or caution annunciator will flash on the PFD, accompanied by an aural tone. A warning is accompanied by a repeating tone, and a caution is accompanied by a single tone. Acknowledging the alert will cancel the flashing and provide a text description of the message. Refer to [03-04 - Airplane related G1000 Warning Messages - Emergency operation procedure](#), [03A-01 - Airplane related G1000 Caution Messages - Emergency operation procedure](#).

Advisory messages related to G1000 NXi system status are shown in white and are accompanied by a white flashing ADVISORY alert. Refer to the G1000 NXi Pilot's Guide and Cockpit Reference Guide for descriptions of the messages and recommended actions (if applicable).

Trend vectors are shown on the airspeed and altimeter displays as a magenta line predicting 6 seconds at the current rate. The turn rate indicator also functions as a trend indicator on the compass scale.

The PFD can be displayed in a composite format for emergency use by pressing the DISPLAY BACKUP button on the audio panel. In the composite mode, the full crew alerting function remains, but no map functions are available.



Figure 1 - Primary Flight Display

## 07-38 Multi-Function Display (MFD) Description

### 1 Multi-Function Display (MFD)

The multi-function display (MFD) typically displays engine data, maps, terrain, traffic and topography displays, and flight planning and progress information. The display unit is nearly identical to the PFD and contains the same controls as previously listed. Additionally the MFD incorporates the controls for the autopilot system.

Engine instruments are displayed on the MFD. Discrete engine sensor information is processed by the Garmin engine airframe (GEA) sub-system. When an engine sensor indicates a value outside the normal operating range, the legend will turn yellow for caution range, and turn red and flash for warning range.

Also refer to [07-24 - Engine Instruments - Description](#).



## 07-39 Audio Panel

### Description

#### 1 Audio Panel

The audio panel contains traditional transmitter and receiver selectors, as well as an integral intercom and marker beacon system. The marker beacon lights appear on the PFD. In addition, a clearance recorder records the last 2 ½ minutes of received audio. Lights above the selections indicate what selections are active. Pressing the red DISPLAY BACKUP button on the audio panel causes both the PFD and MFD to display a composite mode.

## 07-40 Attitude and Heading Reference System (AHRS) Description

### 1 Attitude and Heading Reference System (AHRS)

The attitude and heading reference system (AHRS) uses GPS, rate sensors, air data, and magnetic variation to determine pitch and roll attitude, sideslip and heading. Operation is possible in a degraded mode if the system loses any of these inputs. Status messages alert the crew of the loss of any of these inputs. The AHRS will align while the airplane is in motion, but will align quicker if the wings are kept level during the alignment process.

## 07-41 Air Data Computer (ADC) Description

### 1 Air Data Computer (ADC)

The air data computer (ADC) provides airspeed, altitude, vertical speed, and air temperature to the display system. In addition to the primary displays, this information is used by the FMS and TIS systems.

## 07-42 PFD / MFD Control Unit (KEYPAD)

### Description

#### 1 PFD / MFD Control Unit (Keypad)

The optional PFD / MFD control unit (if OÄM-50-018 is installed) is a user interface allowing for ease of data entry, PFD / MFD operation and NAV / COM tuning. The PFD / MFD control unit is installed in the center armrest. Access to the control unit is accomplished by a folding mechanism. The control unit must be stowed during take-off and landing, all emergencies and abnormal operating procedures.

For more information refer to the Garmin G1000 NXi Pilot's Guide, in the latest effective issue.

# AUTOPILOT

## 07-43 Autopilot GFC700

### Description

## 1 AUTOPILOT SYSTEM

### 1 General

The GFC 700 automatic flight control system (AFCS) if OÄM 50-031 is installed, is a 3 axis autopilot and flight director system which provides the pilot with the following features: altitude preselect and altitude hold (ALT); yaw damper; flight level change with airspeed hold (FLC); vertical speed hold (VS); navigation tracking for VOR (NAV) and GPS (GPS); heading hold (HDG); approach mode and go around (GA) pitch/roll guidance; a return-to-level mode (LVL) . The system consists of autopilot controls on the multi-function display (MFD), servos with autopilot processing logic, flight director processing logic in the GIAs, a control stick-mounted elevator trim switch, a control stick mounted trim interrupt and autopilot disconnect switch, a control stick mounted CWS (control wheel steering) switch, a power lever mounted GA (go-around) switch, a panel-mounted LEVEL (return-to-level mode) button and PFD/MFD-mounted altitude preselect, heading, and course knobs.

The GFC 700 autopilot contains an electric pitch trim system which is used by the autopilot for automatic pitch trim during autopilot operation and by the pilot for manual electric pitch trim when the autopilot is not engaged. The manual electric pitch trim is operated by a split switch on the pilot's control stick.

The GFC 700 autopilot and manual electric trim (MET) will not operate until the system has satisfactorily completed a preflight test. The preflight test begins automatically with initial power application to the autopilot (AVIONIC MASTER switch is set to the ON position).

The following conditions will cause the autopilot to automatically disconnect:

- Electrical power failure
- Internal autopilot system failure
- AHRS malfunction
- Loss of air data computer information

The GFC 700 may be manually disconnected by any of the following means:

- Depressing the red AP DISC button on the pilot's or co-pilot's control stick
- Moving the left (outboard) side of the manual electric trim switch on the pilot's control stick
- Pushing the AP button on the autopilot mode controller when the autopilot is engaged
- Depressing the GA button on the left side of the power lever
- Pulling the AFCS / ESP circuit breaker
- Turning off the AVIONICS MASTER switch
- Turning off the ELECT. MASTER switch

In addition, the CWS (control wheel steering) switch on the pilot's control stick will disconnect the autopilot servos from the airplane flight controls as long as the CWS switch is depressed.

Power to the GFC 700 autopilot and electric trim system is supplied through the AVIONIC MASTER switch and the AFCS / ESP circuit breaker. The AVIONIC MASTER switch can be used as an additional means to disable the autopilot and electric trim system. The red AP DISC switch on the

pilot's control stick will interrupt power to the manual electric trim for as long as the switch is depressed.

Loss of instruments or components of the G1000 NXi system will affect the GFC 700 AFCS as follows:

- Loss of the AHRS will cause the autopilot to disconnect. The autopilot and flight director will be inoperative. Manual electric trim will be available.
- Loss of the heading function of the AHRS will result in loss of the HDG mode. If in HDG mode at the time heading is lost, the autopilot will revert to basic roll mode (ROL).
- Loss of the MFD will not cause the autopilot to disconnect, and will remain engaged in the last active mode. Controls are not available.
- Loss of the PFD will not cause the autopilot to disconnect. The autopilot will remain engaged with no functional limitations.
- Loss of air data computer information will cause the autopilot to disconnect. The autopilot will be inoperative. The flight director will be available except for air data modes (ALT, VS, FLC). Manual electric trim is available.
- Loss of GIA #1 will cause the autopilot to disconnect. The autopilot, flight director and manual electric trim will be inoperative. Loss of GIA #2 will also prevent autopilot and manual electric trim operation, but flight director will be available.
- Loss of the standby airspeed indicator, standby attitude indicator, standby altimeter, or compass will have no effect on the autopilot.
- Loss of both GPS systems will cause the autopilot and flight director to operate in NAV modes (LOC, BC, VOR, VAPP) with reduced accuracy. Course intercept and station crossing performance may be improved by executing intercepts and station crossings in HDG mode, then reselecting NAV mode.

The GFC 700 automatic flight control system (AFCS) installed in the Diamond DA 50 C consists of the following components:

- One GDU which contains the following mode control buttons:

AP	(Autopilot engage/disengage)
FD	(Flight director on/off)
HDG	(Heading mode on/off)
NAV	(Nav mode on/off)
APR	(Approach mode on/off)
ALT	(Altitude hold mode on/off)
VNV	(Vertical navigation mode on/off)
VS	(Vertical speed mode on/off)
FLC	(Flight level change mode on/off)
NOSE UP and NOSE DN	(Vertical mode reference change)
YD	(Yaw damper on/off)

This GDU is installed as the MFD.

- Servos with autopilot processing logic in the pitch, roll, yaw and pitch trim control systems

- Servo mounts and brackets
- Flight director processing logic in the GIAs
- Control stick-mounted manual electric trim (MET) switch (split switch) for pitch trim
- Control stick-mounted trim interrupt and autopilot disconnect switch
- Control stick-mounted CWS (control wheel steering) switch
- Remote-mounted go-around switch (on the left side of the power lever knob)
- Panel-mounted LEVEL (return-to-level mode) button.
- PFD/MFD mounted altitude preselect knob (ALT)
- PFD/MFD mounted heading select knob (HDG)

Flight director commands and autopilot modes are displayed on the PFD. Full AFCS functionality is only available with both displays operating, and will disconnect under certain reversionary conditions.

Upon initial system power-up, the system undergoes a preflight test. At the end of the test, the autopilot disconnect tone sounds and the PFT and AFCS annunciations are removed. Successful completion of the preflight test is required for the autopilot and manual electric trim to engage.

Annunciation of the flight director and autopilot modes is shown in the lower status field of the PFD. In general, green indicates active modes and white indicates armed modes. When a mode is directly selected by the pilot, no flashing of the mode will occur. When automatic mode changes occur, they will be annunciated with a flashing annunciation of the new mode for ten seconds in green. If a mode becomes unavailable for whatever reason, the mode will flash for ten seconds in yellow and be replaced by the new mode in green.

Normal autopilot disconnects are annunciated with a yellow flashing AP on the PFD accompanied by a two second autopilot disconnect tone. Normal disconnects are those initiated by the pilot with the AP DISC switch, the manual electric trim switch (TRIM), the AP button on the MFD mode controller, or the GA button (if ESP/USP is not installed). Abnormal disconnects will be accompanied by a red flashing AP on the PFD accompanied by a continuous autopilot disconnect tone. The disconnect tone and flashing alert may be cancelled by pressing the AP DISC switch or the left side of the MET switch.

Level mode couples pitch and roll modes and is annunciated as both the vertical and lateral modes when active. Pressing the LEVEL button engages the autopilot (if the autopilot is disengaged) in level vertical and lateral modes. Level mode does not track altitude or heading. When the LEVEL button is pressed all armed and active modes are cancelled and the autopilot and flight director revert to level mode for pitch and roll. While in level mode, all other modes are available by pressing the corresponding button.

Refer to the Garmin G1000 NXi Cockpit Reference Guide, P/N 190-02800-( ) and Garmin G1000 NXi Pilot's Guide for the Diamond DA 50 C, P/N 190-02799-( ) for complete descriptions of the G1000 NXi system and operating procedures.

**2 Power Supply**

The AVIONIC MASTER switch supplies power to the avionics bus bar of the radio circuit breakers and the AFCS / ESP circuit breaker.

The following circuit breaker is used to protect the following element of the GFC 700 autopilot:

Circuit Breaker	Function
AFCS / ESP	Supplies power to the autopilot pitch, roll, yaw and pitch trim servos.

**Table 1 - Autopilot circuit breaker**



### 3 AUTOMATIC FLIGHT CONTROL SYSTEM ANNUNCIATIONS AND ALERTS

Automatic Flight Control System (AFCS) Status Alerts:

The following annunciations can appear on the PFD above the airspeed and attitude indicators. Only one annunciation occurs at a time, and messages are prioritized by criticality.

Warning Alerts on the Automatic Flight Control System (AFCS):

Warning Alert	Meaning / Cause
PFT	PREFLIGHT TEST - Preflight system test failed; aural alert sounds at failure.
AFCS	SYSTEM FAILURE - AP and MET are unavailable; FD may still be available.
PTCH	PITCH FAILURE - Pitch axis control failure; AP inoperative.
ROL	ROLL FAILURE - Roll axis control failure; AP inoperative.
YAW	YAW DAMPER FAILURE - Yaw damper control failure; AP inoperative.
PTRM	PITCH TRIM FAILURE (or stuck AP TRIM switch) - if AP engaged, take control of the airplane and disengage AP. If AP disengaged, move AP TRIM switches separately to release.

**Table 2 - Warning Alerts on the Automatic Flight Control System (AFCS)**

Caution Alerts on the Automatic Flight Control System (AFCS):

Caution Alerts	Meaning / Cause
↑ELE	ELEVATOR MISTRIM UP - Pitch servo providing sustained force in the indicated direction.
↓ELE	ELEVATOR MISTRIM DOWN - Pitch servo providing sustained force in the indicated direction.
←AIL	AILERON MISTRIM LEFT - Roll servo providing sustained force in indicated direction.
AIL→	AILERON MISTRIM RIGHT - Roll servo providing sustained force in indicated direction.
←RUD	RUDDER MISTRIM LEFT - Yaw servo providing sustained force in the indicated direction.
RUD→	RUDDER MISTRIM RIGHT - Yaw servo providing sustained force in the indicated direction.

**Table 3 - Caution Alerts on the Automatic Flight Control System (AFCS)**

Advisory Alerts on the Automatic Flight Control System (AFCS):

Advisory Alerts	Meaning / Cause
PFT	PREFLIGHT TEST - Performing preflight system test; aural alert sounds at completion. Do not press the AP DISC switch during servo power-up and preflight system tests as this may cause the preflight system test to fail or never to start (if servos fail their power-up tests). Power must be cycled to the servos to remedy the situation.

**Table 4 - Advisory Alerts on the Automatic Flight Control System (AFCS)**

# PITOT STATIC SYSTEM

## 07-44 Pitot-Static System

### Description

#### 1 Pitot-Static System

Total pressure is measured at the leading edge of a Pitot probe installed at the LH winglet root rib. The static pressure is measured through the static ports also on that probe. To protect against dirt and condensation there are filters in the system. The Pitot probe is electrically heated.

With the alternate static valve, the static pressure in the cabin can be used as static pressure source in the event of a failure of the Pitot-static system.

# STALL WARNING SYSTEM

## 07-45 Stall Warning System

### Description

#### 1 Stall Warning System

The lift transducer of the DA 50 C is located on the leading edge of the left wing below the wing chord line. It is supplied electrically and provides a stall warning, before the angle of attack becomes critical. The stall status is announced to the pilot by a continuous sound in the cockpit.

The lift transducer vane, the mounting plate and the complete housing are heated to prevent icing. Heating is engaged together with the Pitot heating.

A toggle to test switch is provided on the instrument panel. If activated, the stall warning horn shall sound and a system self test is performed. If the system detects a failure during self-test or inflight, a CAS message "STALL WARN FAIL" will be displayed on the PFD.

# BAGGAGE COMPARTMENT

## 07-46 Baggage Compartment

### Description

#### 1 Baggage Compartment

There is a baggage compartment aft of the passenger seat row. The baggage compartment is accessible via the passenger door on the LH side of the airplane. The compartment is divided into 2 main areas, A and B, and 2 compartments below floor level, compartments C and D, as described on limitation placard. Compartment C is the forward compartment and compartment D is the rear compartment. The covers of the compartments must be closed during flight.

Area A is the volume from the front barrier to the the baggage tray step in the middle of the compartment.

Area B is extending from the baggage tray step to the rear wall of the baggage tray.

Max. mass of all items stored only above front barrier height in areas A and B is 50 kg [110 lb]. Refer to [Figure 4](#) .

Baggage must be secured at all times by means of the approved baggage net. Only baggage net attachment configuration in accordance with [Figure 1](#), [Figure 2](#) or [Figure 3](#) may be used. Always use the most suitable baggage net configuration to secure the baggage against shifting.

In case additional straps are used to secure the baggage from shifting, the maximum pre-tension on a single D-plate is 8 kg (17.6 lbs).



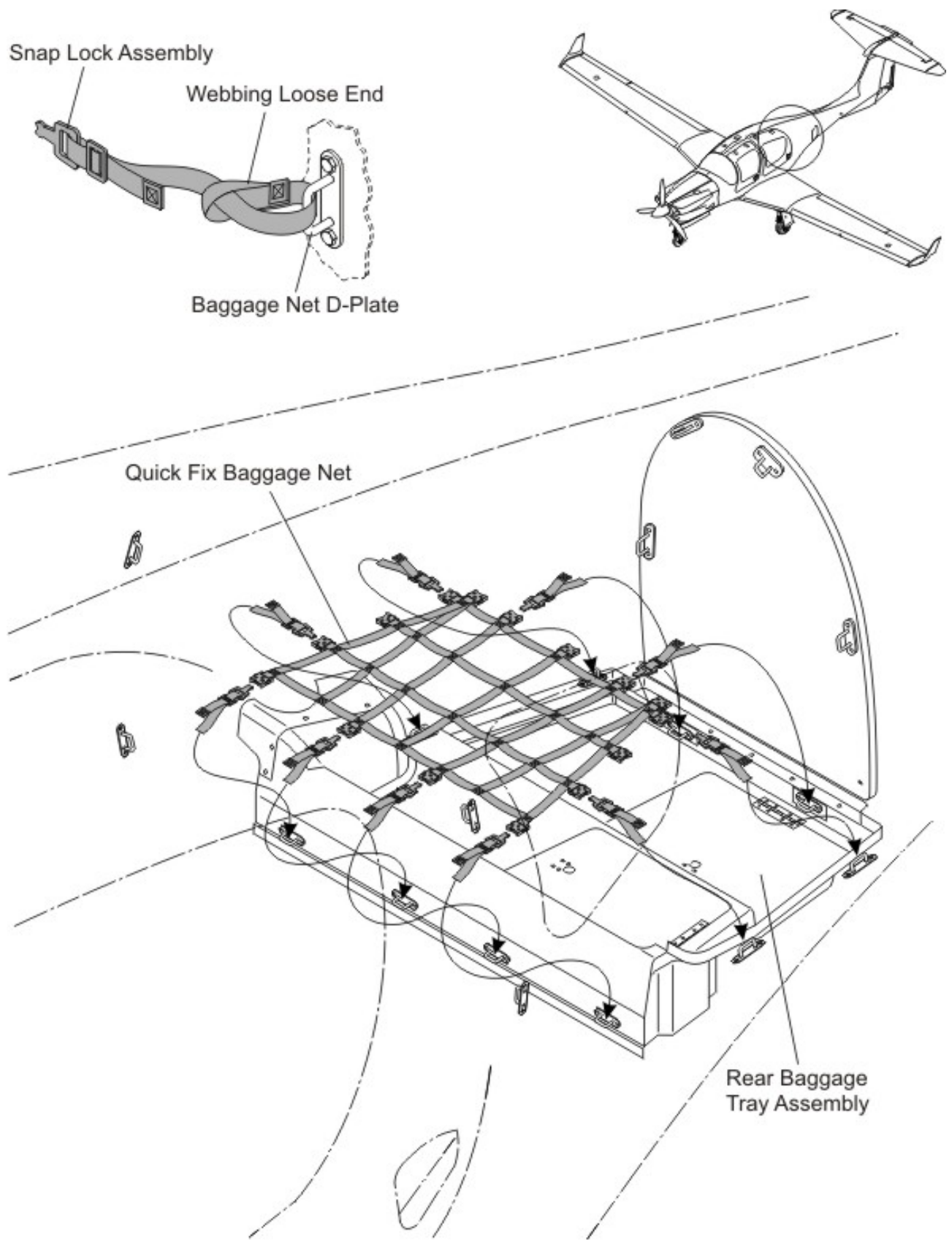

Figure 1 - Baggage Compartment I

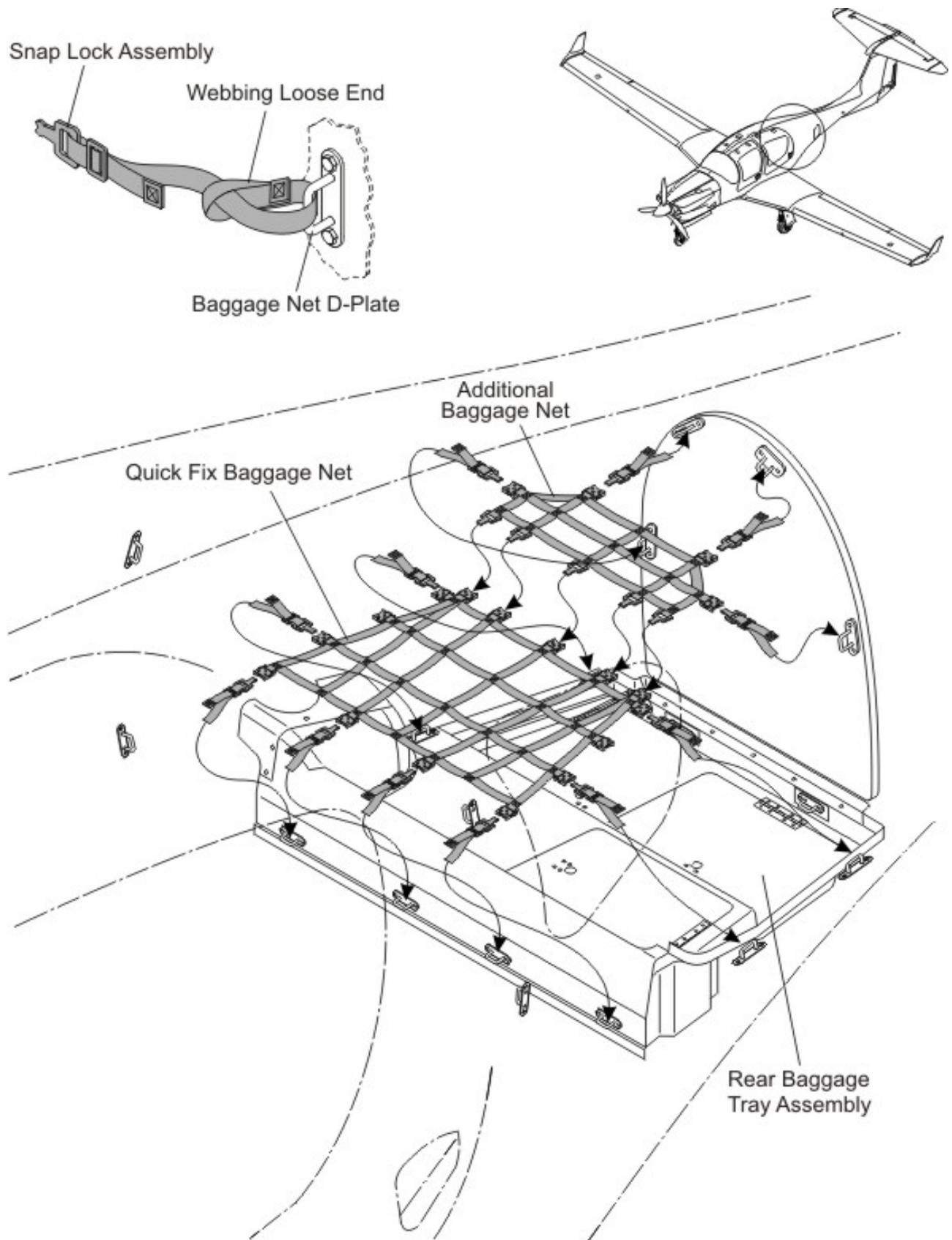

Figure 2 - Baggage Compartment II

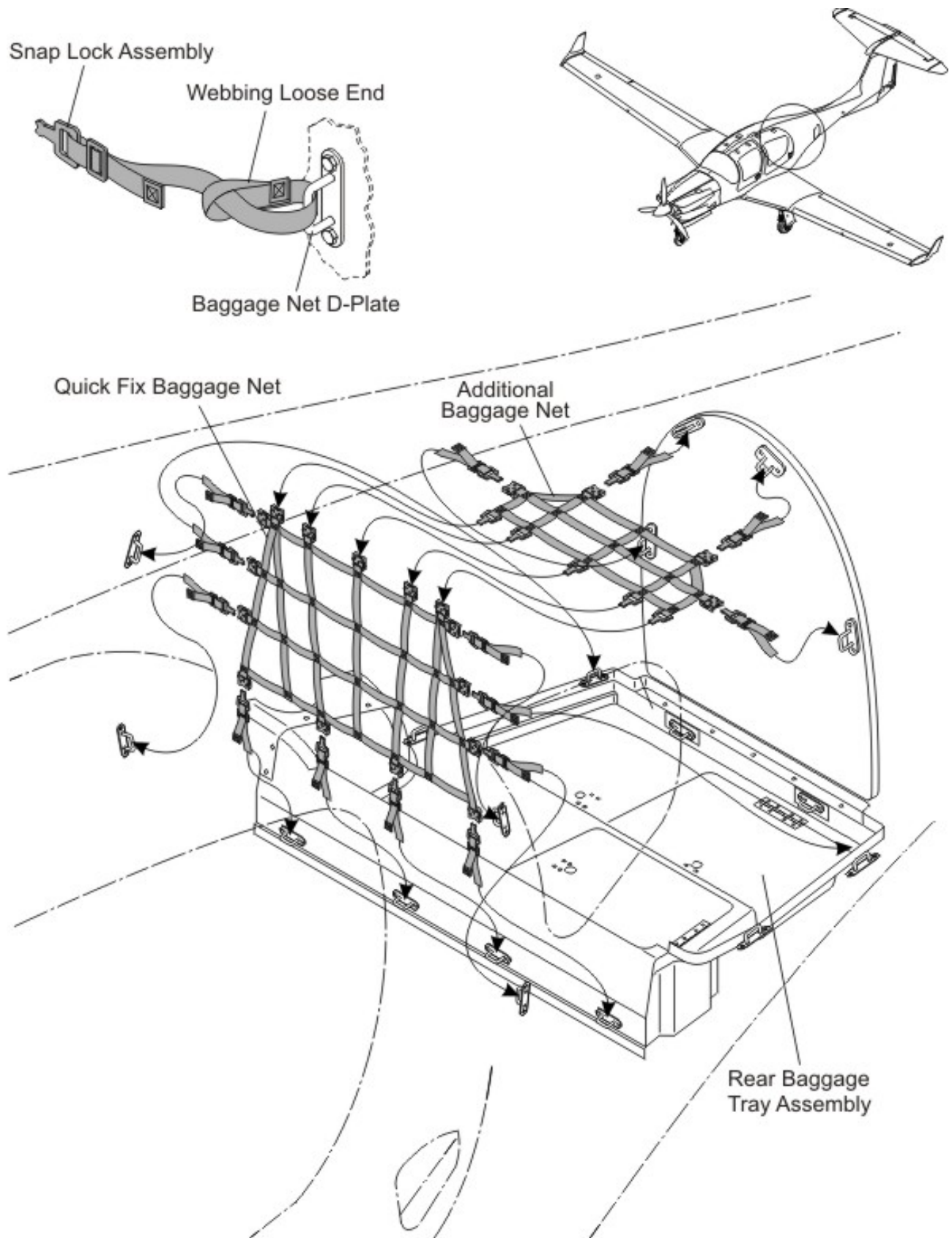
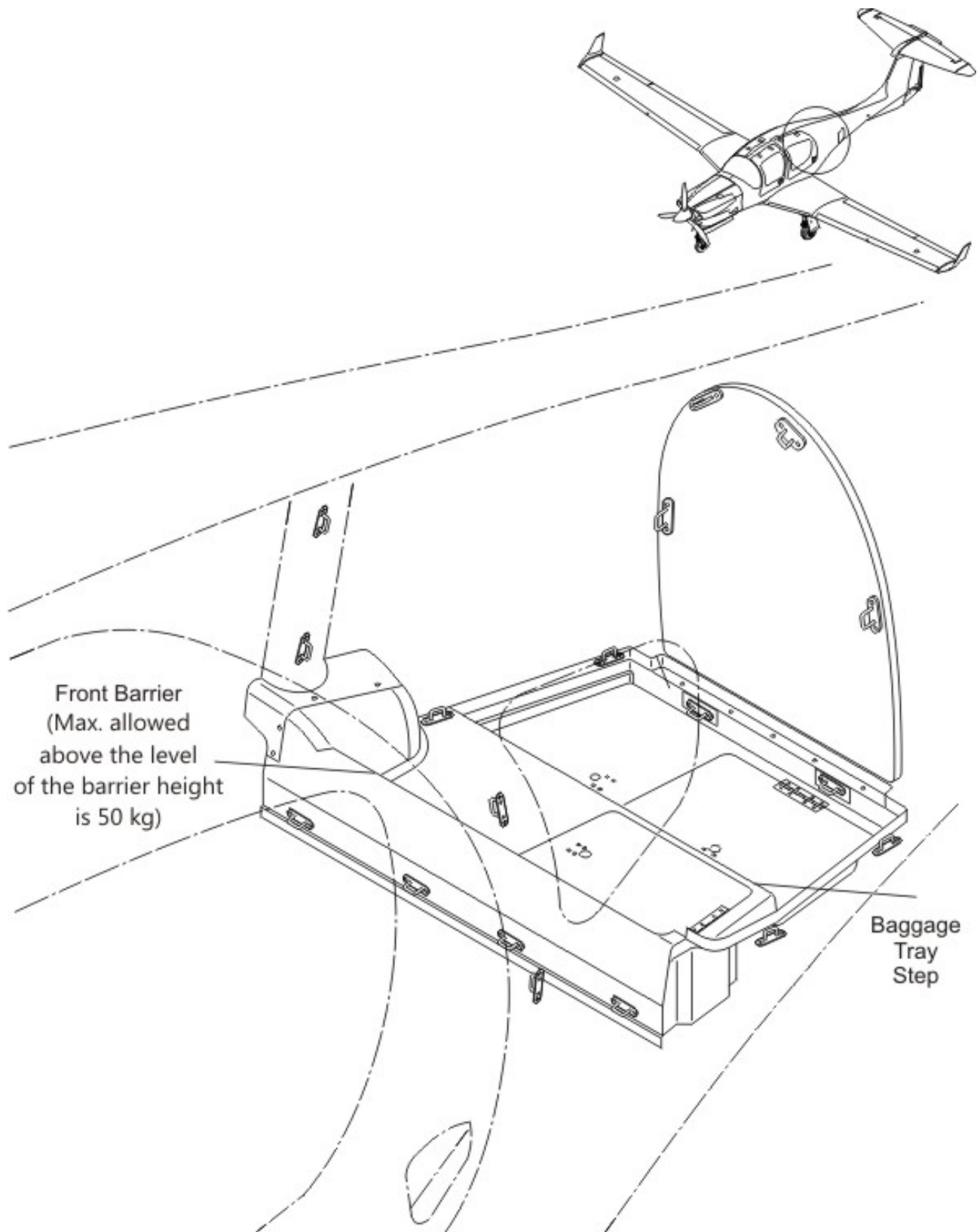

Figure 3 - Baggage Compartment III



**Figure 4 - Front Barrier and Baggage Tray Step**

## 07-47 Trim Weight

### Description

#### 1 TRIM WEIGHT

To adjust the airplanes CG, it is possible to install a trim weight in the lower vertical tail. The trim weight can be varied from 1.0 kg (2.2 lb) to a maximum of 20 kg (44.1 lb) in increments of 1 kg (2.2 lb) by installing the required number of steel plates. The steel plates are fixed by two bolts in the trim weight container. If less than 20 kg (44.1 lb) are used, distance bushings must be installed to prevent moving of the trim weights.

The trim weight system is equipped with a lightning protection system which is connected to the lightning protection system of the airplane.

#### **WARNING**

**THE MAXIMUM TRIM MASS IN THE TRIM WEIGHT CONTAINER  
MUST NOT EXCEED 20.0 KG (44.1 LB).**

#### **WARNING**

**EXCEEDING THE MASS LIMITS WILL LEAD TO AN  
OVERSTRESSING OF THE AIRPLANE AND THE TRIM WEIGHT  
STRUCTURE AND CAUSE A DEGRADATION OF FLIGHT  
CHARACTERISTICS AND FLIGHT PERFORMANCE.**

#### **NOTE**

The removal or installation of the trim weight is limited to authorized personnel. A detailed remove/install procedure is defined in the Airplane Maintenance Manual.

#### **NOTE**

Maintenance procedures are defined in the Airplane Maintenance Manual.

**08**  
**AIRPLANE HANDLING, CARE AND  
MAINTENANCE**

# GENERAL

## 08-01 General Description

### 1 Introduction

This Chapter contains the manufacturer's recommended procedures for proper ground handling and servicing of the airplane. The Airplane Maintenance Manual lists certain inspection and maintenance requirements which must be followed if the airplane is to retain a new plane performance and reliability.



## 08-02 Airplane Inspection Intervals

### Description

#### 1 Airplane Inspection Intervals

Inspections are scheduled every 100, 200, 1000 and 2000 hours. Independent of the flight hours an annual inspection must be performed every year. A non-recurring engine inspection must be performed on new engines after 3 to 6 hours. The respective inspection checklists are prescribed in the Airplane Maintenance Manual.

For maintenance work on engine and propeller, the currently effective Operator's Manuals, Service Instructions, Service Letters and Service Bulletins of Continental Aerospace Technologies and mt-Propeller must be followed. For airframe inspections, the currently effective checklists/manuals, Service Bulletins and Service Instructions of the manufacturer must be followed.

Unscheduled maintenance checks are required after:

- hard landings
- propeller strike
- engine fire
- lightning strike
- occurrence of other malfunctions and damage

Unscheduled maintenance checks are described in the Airplane Maintenance Manual.

## 08-03 Airplane Alterations or Repairs

### Description

#### 1 Airplane Alterations or Repairs

Alterations or repairs to the airplane may be carried out only according to the Airplane Maintenance Manual and only by authorized personnel.

# SERVICING

## 08-04 Refueling Handling

### 1. References

None

### 2. Preliminary Requirements

#### A. Required Conditions

Not applicable

#### B. Required Persons

Not applicable

#### C. Fixtures, Tools and Support Equipment

Not applicable

#### D. Consumable Materials

Not applicable

#### E. Expendable Parts

Not applicable

#### F. Safety Conditions

### WARNING

**DO NOT GET FUEL ON YOUR SKIN. FUEL CAN CAUSE SKIN DISEASE.**

**DO NOT ALLOW FIRE NEAR FUEL. FUEL BURNS AND CAN CAUSE INJURY TO PEOPLE AND DAMAGE TO EQUIPMENT.**

### WARNING

**CONNECT THE AIRPLANE AND THE FUEL SUPPLY VEHICLE TO ELECTRICAL GROUND BEFORE REFUELING. IF YOU DO NOT GROUND THE AIRPLANE, STATIC ELECTRICITY CAN CAUSE FIRE DURING REFUELING.**

### WARNING

**MAKE SURE THAT A SUITABLE FIRE EXTINGUISHER IS AVAILABLE AT ALL TIMES DURING REFUELING/DEFUELING.**

### WARNING

**TURN OFF ALL GROUND EQUIPMENT IN THE REFUELING AREA.**

### WARNING

**DO NOT OPERATE ELECTRICAL SWITCHES IN THE AIRPLANE DURING REFUELING.**

**CAUTION**

USE ONLY APPROVED FUEL TYPES GIVEN IN [02-14 - FUEL - DESCRIPTION](#)

**3. Main Procedure****A. Refueling**

- (1) Ground the airplane and the fuel supply vehicle electrically.
- (2) Remove the fuel filler cap (located on top of the outer wing). Check cap retaining cable for damage.
- (3) Refuel the airplane.
- (4) Install the fuel filler cap.
- (5) Repeat steps [step A.\(2\)](#) to [step A.\(4\)](#) for the other wing.
- (6) Remove the ground cable from the airplane and the fuel supply vehicle.

## 08-05 Engine Oil Level Check

### Handling

#### 1. References

None

#### 2. Preliminary Requirements

##### A. Required Conditions

Not applicable

##### B. Required Persons

Not applicable

##### C. Fixtures, Tools and Support Equipment

Not applicable

##### D. Consumable Materials

Not applicable

##### E. Expendable Parts

Not applicable

##### F. Safety Conditions

Not applicable

#### 3. Main Procedure

##### A. Engine Oil Level Check

- (1) Open the inspection door on the bottom of the upper left cowling.
- (2) Remove the filler cap.
- (3) Clean the oil dip-stick.
- (4) Install the filler cap.
- (5) Remove the filler cap again.
- (6) Read the oil level from the dip-stick.
- (7) If necessary, add engine oil and repeat steps [step A.\(3\)](#) to [step A.\(6\)](#).
- (8) Install the filler cap.
- (9) Close the inspection door.

## 08-06 Gearbox Oil Level Check

### Handling

#### 1. References

None

#### 2. Preliminary Requirements

##### A. Required Conditions

Not applicable

##### B. Required Persons

Not applicable

##### C. Fixtures, Tools and Support Equipment

Not applicable

##### D. Consumable Materials

Not applicable

##### E. Expendable Parts

Not applicable

##### F. Safety Conditions

Not applicable

#### 3. Main Procedure

##### A. Gearbox Oil Level Check

- (1) Open the inspection door on the front of the right cowling half.
- (2) Check gearbox oil level in inspection window by using a flashlight
- (3) Close the inspection door.

---

## 08-07 Tire Inflation Pressure Check Handling

### 1. References

None

### 2. Preliminary Requirements

#### A. Required Conditions

Not applicable

#### B. Required Persons

Not applicable

#### C. Fixtures, Tools and Support Equipment

Not applicable

#### D. Consumable Materials

Not applicable

#### E. Expendable Parts

Not applicable

#### F. Safety Conditions

Not applicable

### 3. Main Procedure

#### A. Tire Inflation Pressure Check

- (1) Remove dust cap from valve stem by turning counterclockwise.
- (2) Connect tire gauge to valve stem, read pressure.
- (3) Correct pressure if necessary (nose wheel 6.1 bar / 88 PSI, main wheels 3.8 bar / 55 PSI).
- (4) Install dust cap on valve stem by turning clockwise.



# GROUND HANDLING

## 08-08 Ground Handling

### Description

#### 1 Ground Handling

To move the airplane on ground, it can be pushed or pulled by hand on the inner section of the propeller blades near the spinner or pushed on the rough surface of the center wing. Do not push on the spinner, as you may damage the spinner which can cause vibration and damage to the engine. Do not use force on the propeller tips or on the airplane control surfaces, as you may damage the propeller or the control surfaces.

It is recommended to use the steering bar which is available from the manufacturer to assist steering. The steering bar is engaged in the appropriate hole in the nosewheel as shown in [Figure 1](#).

The steering bar must be removed before starting the engine.

In the event that the airplane must be pulled out of soft ground or deep snow, towing lines must be used. The towing lines should be attached to the main landing gear struts as high as possible without interfering with the brake lines. The ropes should be long enough to sufficiently clear the nose or tail. A qualified person must sit in the cockpit to maintain control of the airplane using the brakes.

All towing lines must be removed before starting the engine.

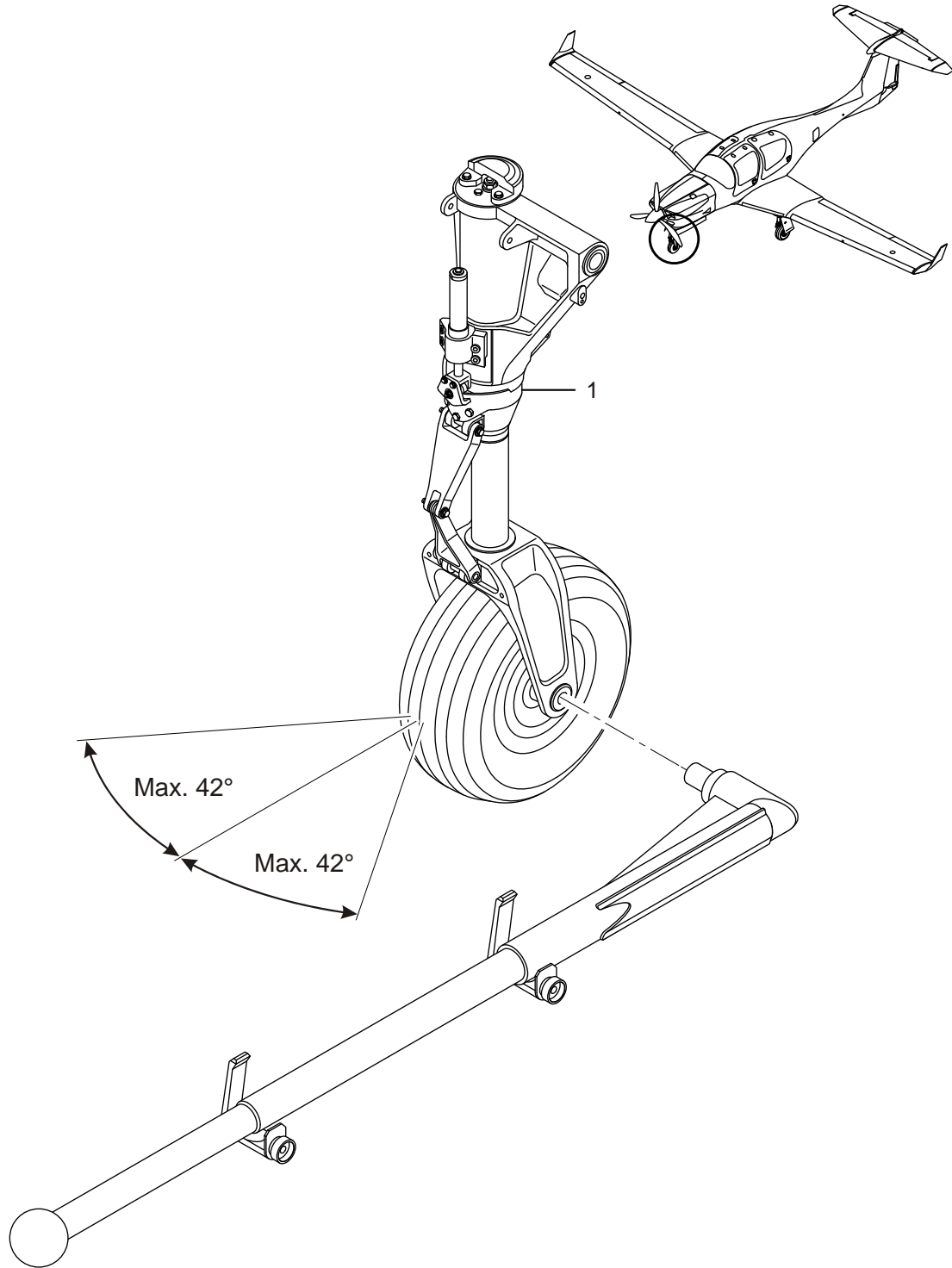

Figure 1 - Steering Bar

Legend

[1, Fig.1] Nose Wheel

## 08-09 Parking

### Description

#### 1 Parking

For short term parking, the airplane must be positioned into the wind, the parking brake must be engaged and the wing flaps must be in the retracted position. For extended and unattended parking, as well as in unpredictable wind conditions, the airplane must be moored to the ground or placed in a hangar. Parking in a hangar is recommended.

If the engine is not used for more than 4 weeks an engine ground run must be performed. Refer to Operation Manual, latest revision.

The manufacturer offers a control surfaces gust lock which can be used to block the primary controls. It is recommended, that the control surfaces gust lock is used when parking outdoors, because otherwise the control surfaces can hit the stops in strong tail wind. This can lead to excessive wear or damage.

The control surfaces gust lock must be removed before flight.

The control surfaces gust lock is installed as follows: (Refer to [Figure 2.](#))

- A. Move the rudder pedals to the rear position.
- B. Engage the control surfaces gustlock with the pedals.
- C. Engage the stick, wrap straps around stick once.
- D. Attach the locks.
- E. Wrap the strap under the lower rail of the rudder pedal assy and attach the lock on the gust lock. Do not wrap the strap around the spindle.
- F. Tighten all straps.

For removal reverse the sequence.

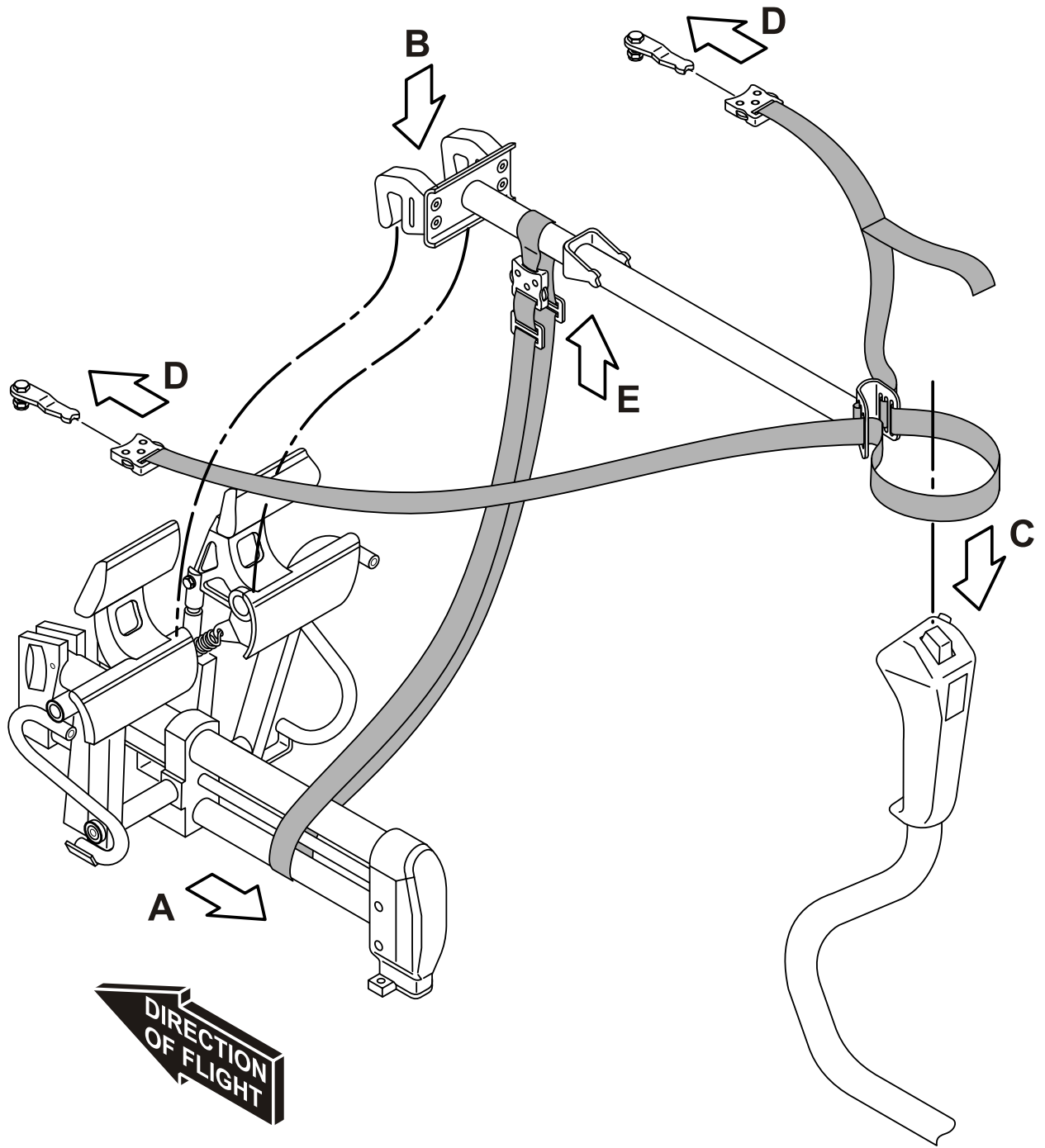

Figure 2 - Gust Lock Installation

## 08-10 Mooring Description

### 1 Mooring

Near the lower end of the tail fin of the airplane there is a hole which can be used to tie down the airplane to the ground. Also on each wing near the wing tip, an eyelet with a metric M8 thread can be installed and used as tie-down points.

## 08-11 Jacking

### Description

#### 1 Jacking

The airplane can be jacked at the two jackpoints located on the lower side of the center wing's LH and RH root ribs as well as at the tail fin.

## 08-12 Cleaning and Care

### Description

## 1 Cleaning and Care

### 1 Painted Surfaces

The entire surface of the airplane is painted with a weatherproof two component paint. Nevertheless, it is recommended to protect the airplane against moisture and dampness. It is also recommended not to store the airplane outside for long periods of time.

Dirt, insects, etc. can be removed with water alone and if necessary with a mild detergent. An automotive paint cleaner can be used for stubborn spots. For best results, clean the airplane after the day's flying is ended, so that the dirt will not become ingrained.

Oil stains, exhaust stains, etc. on the lower fuselage skin can be removed with a cold detergent. Before starting, ensure that the detergent does not affect the surface finish. Use commercial automotive preservatives without silicone additives to conserve the paint finish.

The airplane must be kept clean. The bright surface prevents the structure from overheating.

Excessive dirt deteriorates the flight performance.

### 2 Front and Rear Door

The windscreen and all windows should be cleaned with 'Plexiklar' or any other acrylic glass detergent if available; otherwise use lukewarm water. Final cleaning should be carried out with a clean piece of chamois leather or soft cloth. Never rub or polish dry acrylic glass.

### 3 Propeller

Damage and malfunctions during operation must be inspected by authorized personnel.

#### 3.1 Propeller Surface

The manufacturer uses PU paint or acrylic paint which is resistant to almost any solvent. The blades may be treated with commercial automotive cleaning agents or preservatives. The penetration of moisture into the wooden core must be avoided by all means. Should doubts arise, an appropriately rated inspector must be consulted.

### 4 Engine

Engine cleaning is part of the scheduled inspections.

### 5 Interior Surfaces

The interior should be cleaned using a vacuum cleaner. All loose items (pens, bags etc.) should be removed or properly stored and secured.

All instruments can be cleaned using a soft dry cloth. Plastic surfaces should be wiped clean using a damp cloth without any cleaning agents.

The leather interior should be treated with leather sealer within 3 months since new, and then at intervals of 3 to 6 months. Clean the leather interior with an appropriate mild leather cleaning agent and a soft cleaning brush for leather.

Note that the acrylic glass windows transmit the ultraviolet radiation from the sun.



## 08-13 Cleaning the Aircraft from Ice and Snow

### Description

#### 1 Cleaning from Ice and Snow

Approved fluids for cleaning the aircraft from ice and snow are:

Manufacturer	Name
Kilfrost	TKS 80
Aeroshell	Compound 07
	AL-5 (DTD 406B)

**Table 1 - Fluids for cleaning the aircraft from ice and snow**

- A. Remove any snow from the airplane using a soft brush.
- B. Spray cleaning fluid onto ice-covered surfaces using a suitable spray bottle.
- C. Use a soft piece of cloth to wipe the airplane dry.

**09**  
**SUPPLEMENTS**

## 09-01 Supplements

### Description

## 1 Introduction

Chapter 9 contains information concerning additional (optional) equipment of the DA 50 C.

Unless otherwise stated, the procedures given in the Supplements must be applied in addition to the procedures given in the main part of the Airplane Flight Manual.

All approved supplements are listed in the List of Supplements in this Chapter.

The Airplane Flight Manual contains exactly those Supplements which correspond to the installed equipment according to [06-10 - Equipment - Description](#).

### 1 List of Supplements

Airplane S/N:		Registration:		Date:	
No.	Title	Issue	Reference	applicable	
				YES	NO
A034	Electronic Stability and Protection System (ESP)	001	<a href="#">DA50A034-2651N-FA034-01</a>		
N022	Operation in China	001	<a href="#">DA50N022-2651N-FN022-01</a>		
O008	Removable RH Control Stick	001	<a href="#">DA50O008-2651N-FO008-01</a>		
O015	Business seating configuration passenger seat row	001	<a href="#">DA50O015-2651N-FO015-01</a>		
S003	Ice Protection System for Flight into known Icing	002	<a href="#">DA50S003-2651N-FS003-02</a>		
S004	Continuous Flow Oxygen System	002	<a href="#">DA50S004-2651N-FS004-02</a>		
S007	Air Conditioning System	002	<a href="#">DA50S007-2651N-FS007-02</a>		
S013	Flight Stream 510	001	<a href="#">DA50S013-2651N-FS013-01</a>		

**Table 1 - List of Supplements**