

MANDATORY SERVICE BULLETIN

MSB 42-137/1

MSB 42NG-079/1

supersedes MSB 42-137 / MSB 42NG-079

I TECHNICAL DETAILS

I.1 Category

Mandatory.

I.2 Airplanes affected

Type: DA 42, DA 42 M, DA 42 NG, DA 42 M-NG

Serial numbers:

42.004 through 42.391,	42.N100 through 42.N250,
42.394 through 42.396,	42.N300 through 42.N381,
42.399 through 42.402,	42.N391,
42.405 through 42.416,	42.MN001 through 42.MN034,
42.427,	42.MN037 through 42.MN042,
42.AC001 through 42.AC135,	42.MN050 through 42.MN055,
42.AC137 through 42.AC145,	42.MN057, 42.MN058,
42.AC148, 42.AC150,	42.MN100 through 42.MN103,
42.AC151, 42.AC152,	42.NC001 through 42.NC004,
42.M001 through 42.M026,	42.NC006 through 42.NC008,
42.N001 through 42.N067,	42.NW001 through 42.NW064

I.3 Date of effectivity

21-Oct-2019

I.4 Time of Compliance

Within the next 100 flight hours from the date of effectivity but not later than 31-Oct-2020 and thereafter at intervals not exceeding 200 ± 10 flight hours or 12 months ± 30 days.

Note: Installation of an improved T-yoke axle D60-5320-00-32 in accordance with RSB 42-139 / RSB 42NG-081 is the terminating measure for the repetitive inspection.

I.5 Subject

Inspection of rudder T-yoke axle nut for looseness.

ATA-Code: 53-20

I.6 Reason

On two airplanes a loose T-yoke axle (LN 9037-M6x90) nut was reported. A loose T-yoke axle nut allows vertical movement of the T-yoke axle, possibly causing reduced rudder control.

This Service Bulletin requires inspection of the T-yoke axle nut for looseness.

I.7 Concurrent Documents

None.

I.8 Approval

The technical content of this document has been approved under the authority of EASA Design Organization Approval ref. EASA.21J.052.

I.9 Accomplishments / Instructions

See WI-MSB 42-137 / WI-MSB 42NG-079, latest effective issue.

I.10 Mass (Weight) and CG

Mass and Center of Gravity are not affected.

II PLANNING INFORMATION**II.1 Material and Availability**

See WI-MSB 42-137 / WI-MSB 42NG-079, latest effective issue.

II.2 Special Tools

None.

II.3 Labour Effort

Approx. 0.25 hours for inspection when carried out along with 200 hours or annual inspection, otherwise 1.5 hours.

II.4 Credit

Labour effort for initial inspection for all airplanes within warranty period.

II.5 Reference Documents

DA 42 Series Airplane Maintenance Manual, Doc. No. 7.02.01, latest effective issue.

DA 42 NG Airplane Maintenance Manual, Doc. No. 7.02.15, latest effective issue.

III REMARKS

1. All work must be done by a certified aircraft service station or a certified aircraft maintenance mechanic.
2. All work, particular that which is not especially described in this Service Bulletin, must be done in accordance with the referenced Maintenance Manual.
3. Completion of all work must be recorded in the log book.
4. If material and/or labor hours are subject to be credited through Diamond Aircraft Industries, the Service Bulletin must be done by an authorized Diamond Service Center within the time of compliance and the Warranty Application incl. Work Report must be sent not later than 30 days after completion of work.
5. In case of doubt contact Diamond Aircraft Industries GmbH.

**EXECUTION REPORT TO
SERVICE BULLETIN
MSB 42-137/1
MSB 42NG-079/1**

AIRPLANE INFORMATION

Airplane Serial Number _____

Airplane Registration _____

Airplane Operator _____

Hours of operation of airplane _____

No. of landings _____

Hours of operation-engine LH _____

RH _____

Typical operation of airplane private, club, training, other _____

Nut was found loose no - yes - _____
Date, Name, SignPlease e-mail the completed form to executionreports@diamondaircraft.com

WORK INSTRUCTION

WI-MSB 42-137

WI-MSB 42NG-079

I GENERAL INFORMATION

I.1 Subject

Inspection of rudder T-yoke axle nut for looseness.

I.2 Reference Documents

DA 42 Series Airplane Maintenance Manual, Doc. No. 7.02.01, latest effective issue.

DA 42 NG Airplane Maintenance Manual, Doc. No. 7.02.15, latest effective issue.

I.3 Remarks

- a) All work must be done by a certified aircraft service station or a certified aircraft maintenance mechanic.
- b) All work, in particular if not described in this work instruction, must be done in accordance with the referenced maintenance manual.
- c) For conversion factors between SI units and US/Imperial units refer to AMM Chapter 02.
- d) In case of doubt, contact Diamond Aircraft Industries GmbH.

II DRAWINGS, SPECIAL TOOLS & MATERIALS

II.1 Drawings

None.

II.2 Special Tools

None.

II.3 Material

None.

III INSTRUCTIONS

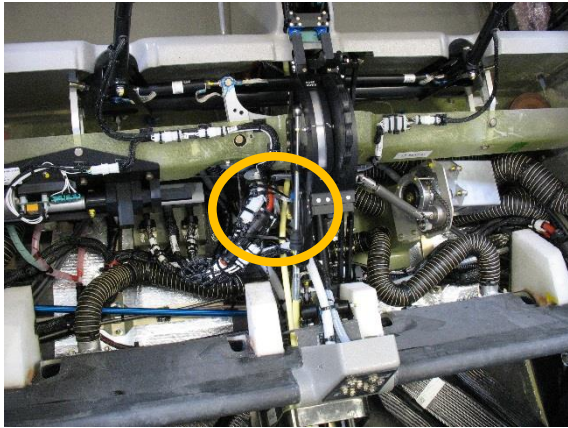
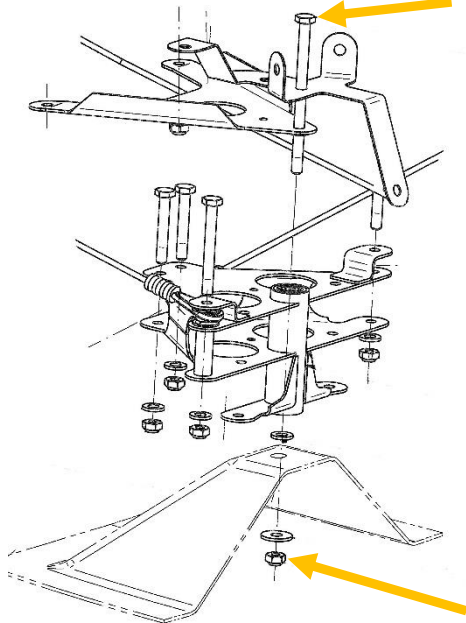
1	Remove the pilot and copilot seat in accordance with AMM Section 25-10.
2	Remove the middle tunnel front cover in accordance with AMM Section 25-10.
3	<p>Check the self-locking nut for correct torque:</p> <ul style="list-style-type: none"> • Block the self-locking nut with a ring-wrench. • Apply a torque of approx. 6 Nm to the head of the T-yoke axle.
	 
4	<p>If the T-yoke axle can be rotated more than one half turn or if the nut is loose:</p> <ul style="list-style-type: none"> • do a condition inspection in accordance with AMM and MSB 42-087 / MSB 42NG-016, • correct any deficiencies, • replace the self-locking nut with a new self-locking nut.
5	Install the middle tunnel front cover in accordance with AMM Section 25-10.
6	Install the pilot and copilot seat in accordance with AMM Section 25-10.
7	Clean working area and check for foreign objects.
8	Perform functional check of altered, repaired and new parts.
9	Test all systems in working area for function.
10	Make necessary entries into aircraft logs.