

TEMPORARY REVISION

AMM-TR-MÄM 42-1265

New Fire Extinguisher

This Temporary Revision AMM-TR-MÄM 42-1265 is approved in conjunction with the Mandatory Design Change Advisory MÄM 42-1265 and is valid in conjunction with the Airplane Maintenance Manual (AMM) until this Temporary Revision has been incorporated into the AMM.

The limitations and information contained herein either supplement or, in the case of conflict, override those in the AMM.

The technical information contained in this document has been approved under the authority of DOA No. EASA.21J.052.

Doc. No.	Section	Affected Pages
7.02.01	03-00-00	7a, 7aa
	05-00-00	3a, 3aa
	05-10-00	4a, 4aa, 6a, 6aa
	05-28-50	22a, 22aa
	26-CONTENTS	1a, 1aa
	26-00-00	1a, 2a, 2b, 2c, 3a, 3aa, 201a, 201aa

Instruction

- Print this document on yellow paper (double-sided).
- Insert this cover page as the first page of the AMM.
- Insert the other pages of this Temporary Revision adjacent to or in front of the corresponding AMM pages.

Intentionally left blank

AFFECTED CHAPTERS:

CHAPTER 03
GENERAL DESCRIPTION OF THE AIRPLANE

2. Equipment Data

The following item is amended to read:

ATA Chapter	Equipment/System	Manufacturer/Address	Direct Shipping Approved
26	Fire Extinguisher AIR TOTAL HAL 1:	TOTAL Feuerschutz GmbH Industriestr. 13 68526 Ladenburg Germany Tel: +49-6203-75-369 Fax: +49-6203-75-265 Website: www.total-feuerschutz.de	yes

The following item is added:

ATA Chapter	Equipment/System	Manufacturer/Address	Direct Shipping Approved
26	Fire Extinguisher Amerex A620T and 337TS:	Amerex Corporation 7595 Gadsden Highway Trussville, AL 35173 USA Tel: +120-56553271 Website: www.amerex-fire.com	yes

Intentionally left blank

CHAPTER 05
TIME LIMITS AND MAINTENANCE CHECKS

2. Chapter Configuration

H. Referenced Maintenance Data

The following items are added to the list:

Supplier	Document Name	Document No.
Amerex Corp.	Owners Service Manual, Installation, Operating & Servicing Instructions	05602
TOTAL Feuerschutz	Component Maintenance Manual with Illustrated Parts List, Part No. 74-00	ATA 26-24-05

Intentionally left blank

Section 05-10
Time Limits

4. Component Time Limits

A. Maintenance Requirements

The following item is amended to read:

ATA Ch.	Component	Maintenance Requirement	Interval	
			hrs.	calendar time
26	Fire extinguisher AIR TOTAL HAL 1.	Overhaul by fire extinguisher manufacturer (refer to Components Maintenance Manual with Illustrated Parts List, latest revision).	-	10 yrs ± 60 days

The following items are added to the existing list:

ATA Ch.	Component	Maintenance Requirement	Interval	
			hrs.	calendar time
26	Fire extinguisher Amerex A620T.	Overhaul per Owners Service Manual (refer to Owners Service Manual Installation, Operating & Servicing Instructions, latest revision).	-	6 yrs ± 60 days
26	Fire extinguisher Amerex A620T.	Hydrostatic Test per Owners Service Manual (refer to Owners Service Manual Installation, Operating & Servicing Instructions, latest revision).	-	12 yrs ± 90 days

Intentionally left blank

B. Airplane Life-Limited Components

The following item is added:

ATA Ch.	Component	Replacement Time	
		hrs.	calendar time
26	Fire extinguisher Amerex 337TS.	12 years after production date as shown on the label of the fire extinguisher.	

Intentionally left blank

Section 05-28-50

Maintenance Checklist Airframe

2. Cabin

G. Miscellaneous Items in Cabin

The following item is amended to read:

<i>100 hr items marked * apply to US registered airplanes only</i>		Interval					Initials
Inspection Items, Cabin, Miscellaneous	100	200	1000	2000	Time		
<p>2. Examine the fire extinguisher:</p> <ul style="list-style-type: none"> - Make sure that the fire extinguisher will release from the fire extinguisher mount. - Look for physical damage, corrosion, leakage or clogged nozzle. - Examine the fire extinguisher label for damage. - Make sure that the tamper seal is not broken. - Make sure that the container of the fire extinguisher is full: <ul style="list-style-type: none"> - Use the pressure gauge to examine the pressure. The pressure must be in the green arc. - If the fire extinguisher AIR TOTAL HAL 1 or Amerex 337TS (MÄM 42-1265) is installed: Examine the weight of the fire extinguisher. Refer to the maintenance description on the fire extinguisher label. <p>Refer to Section 26-00.</p>	X*	X	X	X			

Intentionally left blank

CHAPTER 26
FIRE PROTECTION
TABLE OF CONTENTS

Maintenance Practices

The Table of Contents is amended to read:

1.	General.....	201
1A.	Replace the Fire Extinguisher Amerex 337TS	201a
2.	Remove/Install an Engine Overheat Detector.....	201
3.	Overheat Detector Test	202

Intentionally left blank

CHAPTER 26

FIRE PROTECTION

1. General

The first paragraph is amended to read:

This Chapter tells you about the fire extinguisher installed in the airplane. There are three approved fire extinguishers for the DA 42 NG:

– AIR TOTAL HAL 1

The fire extinguisher AIR TOTAL HAL 1 uses a liquid gas which is non-toxic and does not have a residue.

– Amerex A620T

The fire extinguisher Amerex A620T uses a siliconized sodium bicarbonate based dry chemical.

– Amerex 337TS

The fire extinguisher Amerex 337TS uses a Halocarbon Clean Agent named Halotron BrX.

See the fire extinguisher manufacturer's manual for more data about the extinguisher.

The Chapter also tells you about the installation of the overheat detector installed in each engine nacelle. See the overheat detector manufacturer's manual for more data about the overheat detector.

Figure 1 is amended to read:

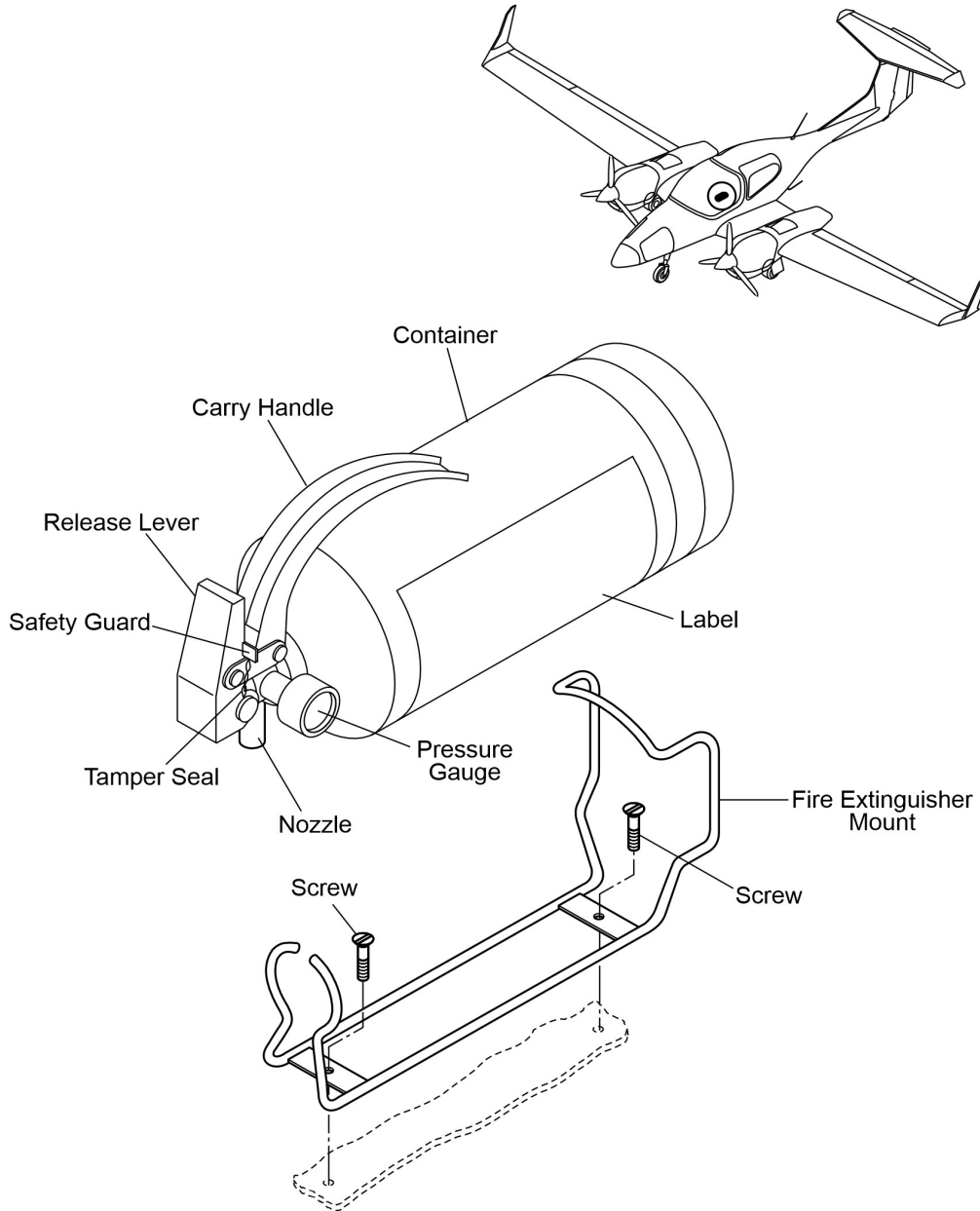

Figure 1: The Fire Extinguisher Installation of the Fire Extinguisher AIR TOTAL HAL 1

Figure 1A is added:

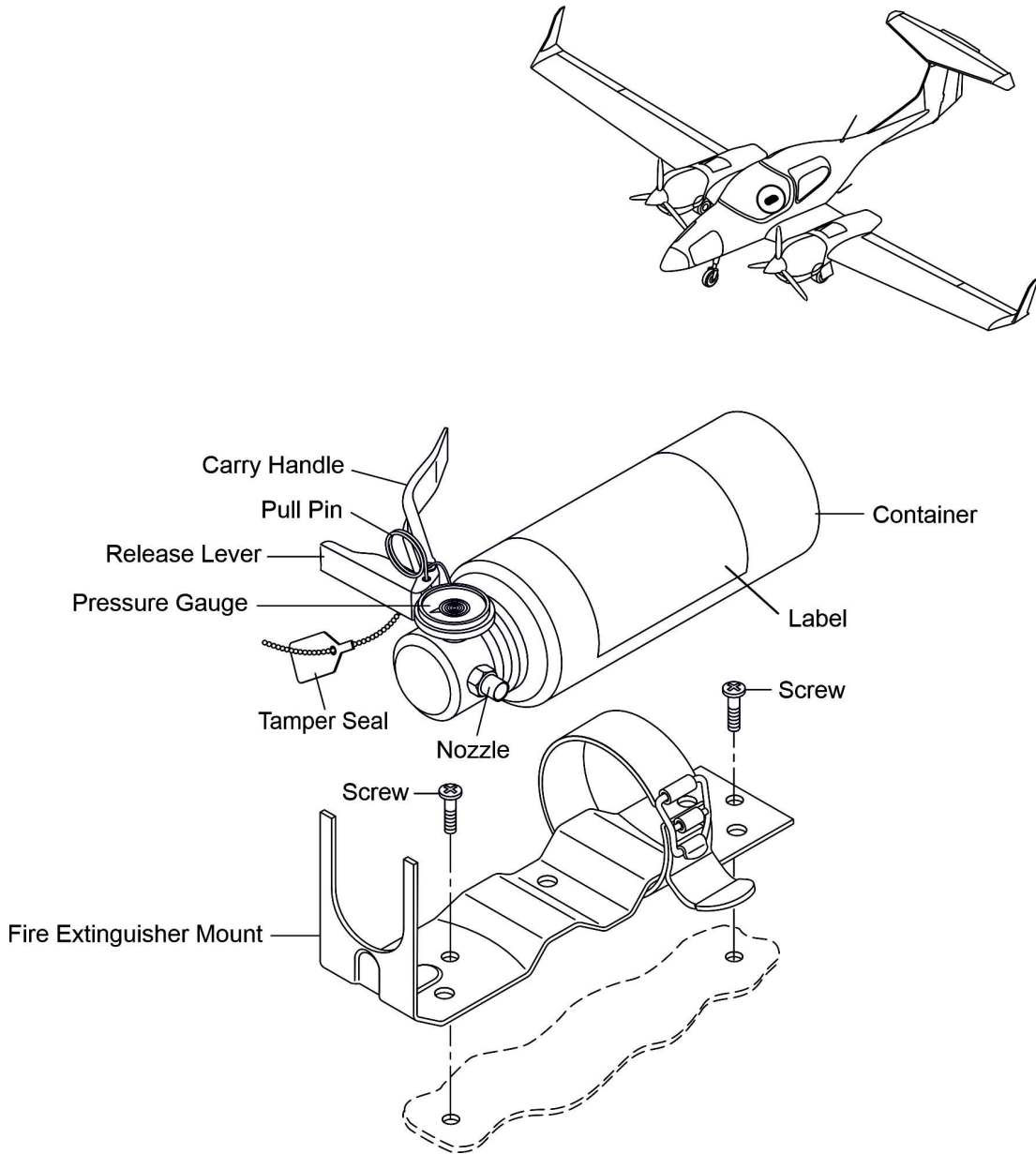

Figure 1A: The Fire Extinguisher Installation of the Fire Extinguisher Amerex A620T

Figure 1B is added:

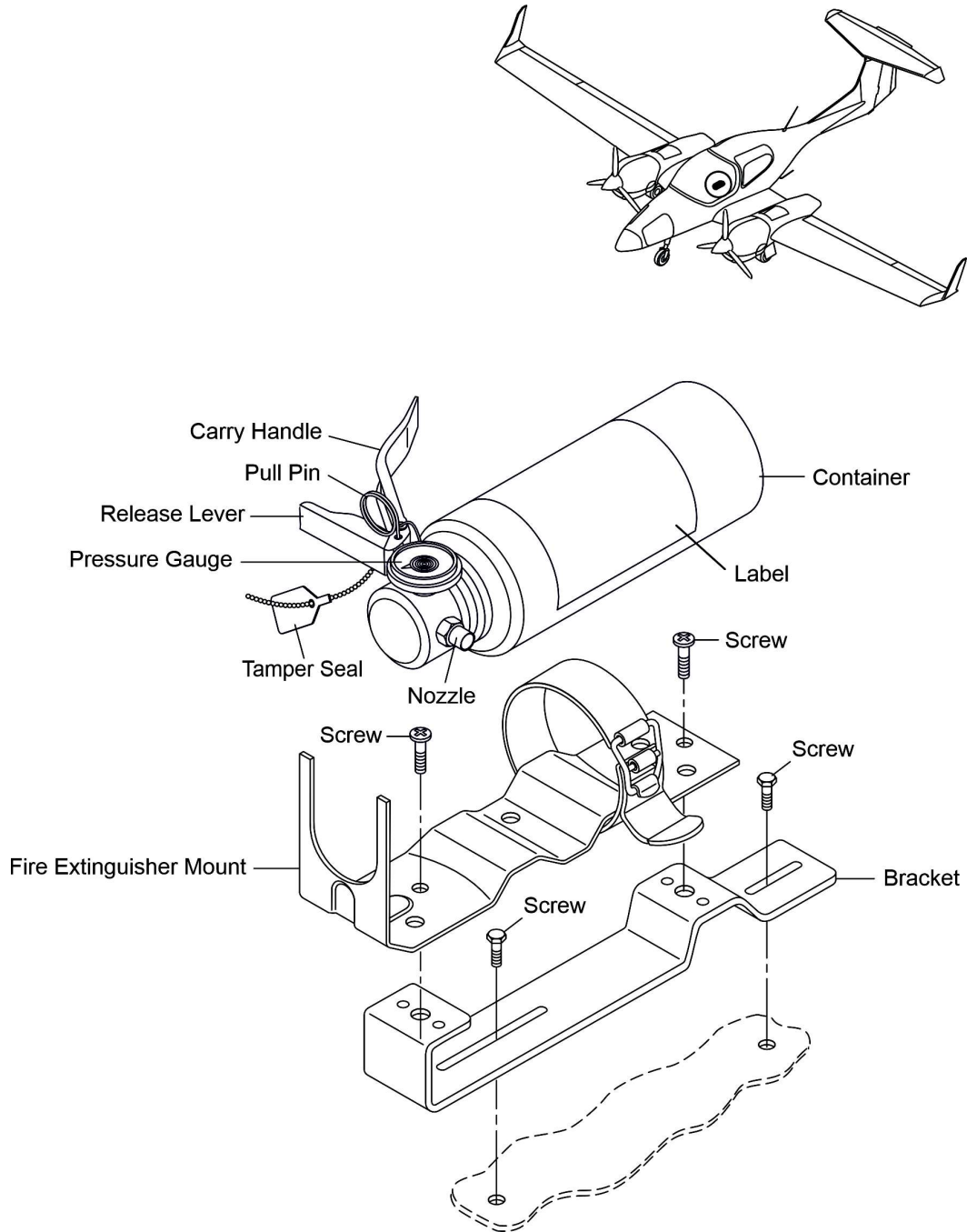

Figure 1B: The Fire Extinguisher Installation of the Fire Extinguisher Amerex 337TS

2. Description

A. Fire Extinguisher

The section is amended to read:

Figures 1, 1A and 1B show the installation of the fire extinguisher in the airplane. The fire extinguisher is located behind the co-pilot's seat (refer to Section 25-00, Figure 1). Two screws attach the fire extinguisher mount to the closing rib between the front and the rear main bulkhead.

Intentionally left blank

Maintenance Practices

The first paragraph is amended to read:

1. General

These Maintenance Practices tell you how to replace the fire protection equipment of the aircraft. They also tell you how to test the engine overheat detector. Refer to the overheat detectors manufacturer's manuals for more data about the overheat detector.

The following procedure is added:

1A. Replace the Fire Extinguisher Amerex 337TS

Detail Steps/Work Items		Key Items/References
(1)	Weigh the new fire extinguisher Amerex 337TS without the fire extinguisher mount.	This weight is the initial weight. Refer to Figure 1B.
(2)	Record the initial weight on the bottom of the new fire extinguisher with two decimal places (for example: 1.34 kg (2.95 lb)).	Use a permanent black marker.

Intentionally left blank