

# SERVICE INFORMATION

## NO. SI 42-247

## NO. SI 42NG-133

**NOTE:** SI's are used only:  
1) To distribute information from DAI to our customers.  
2) To distribute applicable information/documents from our suppliers to our customers with additional information.  
Typically there is no revision service for SI's. Each new information or change of that will be sent along with a new SI.

## I. TECHNICAL DETAILS

### 1.1 Airplanes affected:

All DA 42 /M /NG /M-NG airplanes

### 1.2 Subject:

Garmin Service Bulletin No. 22117 Rev. B

ATA-Code: 22-00

### 1.3 Reason:

Garmin has issued Service Bulletin No. 22117 Rev. B recommending replacement of the cable retention pins with new longer cable retention pins at the GSM 86 servo gearbox assembly.

### 1.4 Information:

For detailed technical information refer to Garmin Service Bulletin No. 22117 Rev. B which is applicable without any further additions or restrictions.

## II. OTHERS

Garmin Service Bulletin No. 22117 Rev. B is attached to this Service Information.

In case of doubt contact Garmin Ltd.



1200 E. 151<sup>st</sup> Street  
Olathe, KS 66062  
913-397-8200

## SERVICE BULLETIN

NO.: 22117 Rev B

**TO:** All Garmin Aviation Service Centers  
**DATE:** December 20, 2022  
**SUBJECT:** Cable Retention Pins  
**CERTIFICATION AUTHORIZATION:** TSO Authorization (see Approval section for details)  
**REVISION B:** Adjusted Warranty Information

TSO authorization does not provide installation airworthiness approval. Separate installation airworthiness approval is required for type certified aircraft. Notification of revision to any Garmin STC(s) will be provided under a separate service bulletin.

---

### PRODUCTS AFFECTED

All 011-01904-XX and 011-02490-XX Garmin GSM 86 Servo Gearboxes with capstan output devices that use 233-00075-01 and 233-00075-02 Cable Retention Pins are affected.



### NOTE

*Installations that use a GSM 86 with a crank arm or sprocket output device are not affected.*

Both the -01 and -02 Cable Retention Pins have no grooves (See Figure 1). The -01 Cable Retention Pin is 1.48" long and the -02 is 1.60" long (See Figure 1).

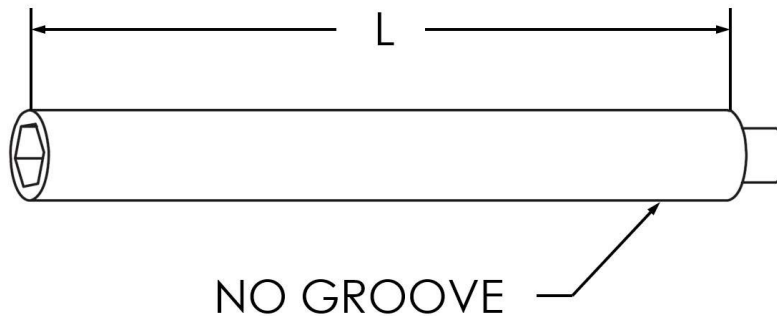

Figure 1 - 233-00075-01 and 233-00075-02 Cable Retention Pins

© 2022

Garmin Ltd. or its subsidiaries

All Rights Reserved

Except as expressly provided herein, no part of this document may be reproduced, copied, transmitted, disseminated, downloaded or stored in any storage medium, for any purpose without the express prior written consent of Garmin. Garmin hereby grants permission to download a single copy of this document and of any revision to this document onto a hard drive or other electronic storage medium to be viewed and to print one copy of this document or of any revision hereto, provided that such electronic or printed copy of this document or revision must contain the complete text of this copyright notice and provided further that any unauthorized commercial distribution of this document or any revision hereto is strictly prohibited.

## **PURPOSE**

In the event of the loss of the clutch retaining bolt, the output shaft drive pin may become partially disengaged causing the capstan to bind.

## **DESCRIPTION**

This Service Bulletin contains instructions to replace the cable retention pins with new longer cable retention pins to ensure the GSM servo gearbox capstan is free to rotate in the event that the clutch retaining bolt is not retained.

## **MATERIALS**

233-00075-03 and 233-00075-04 Cable Retention Pins

## **COMPLIANCE**

Compliance with the service bulletin is recommended at a maintenance interval not to exceed 1 year.

## **REFERENCES**

GSM 86 Servo Gear Box Installation Manual 190-00303-83

## **APPROVAL**

**TSO authorization does not provide installation airworthiness approval. Separate installation airworthiness approval is required for type certified aircraft. Notification of revision to any Garmin STC(s) will be provided under a separate service bulletin.**

## **MANPOWER**

One (1) hour labor per affected GSM 86.

## **WARRANTY INFORMATION**

Labor costs incurred with this modification are reimbursable for GSM 86 servos covered by the original Garmin Warranty or the aircraft's factory warranty (excluding extended warranties).

The warranty claim must be submitted by 12/31/24.

To ensure proper warranty reimbursement when completing the warranty claim, include the following:

- GSM 86 Serial Number(s)
- Aircraft make and model
- Aircraft serial number and registration

## **MODIFICATION INSTRUCTIONS**

1. Refer to the applicable airframe specific maintenance manual to gain access to the GSM 86.
2. Gain access to the cable guard pins by removing cable guard hardware including screws, washers, and top ring.
3. Replace each cable retention pin with a new part number as listed in Table 1.

**Table 1. Cable Retention Pins**

<b>New Pin P/N</b>	<b>Replaces Pin P/N</b>
233-00075-03 (one groove)	233-00075-01 (1.48")
233-00075-04 (two grooves)	233-00075-02 (1.60")

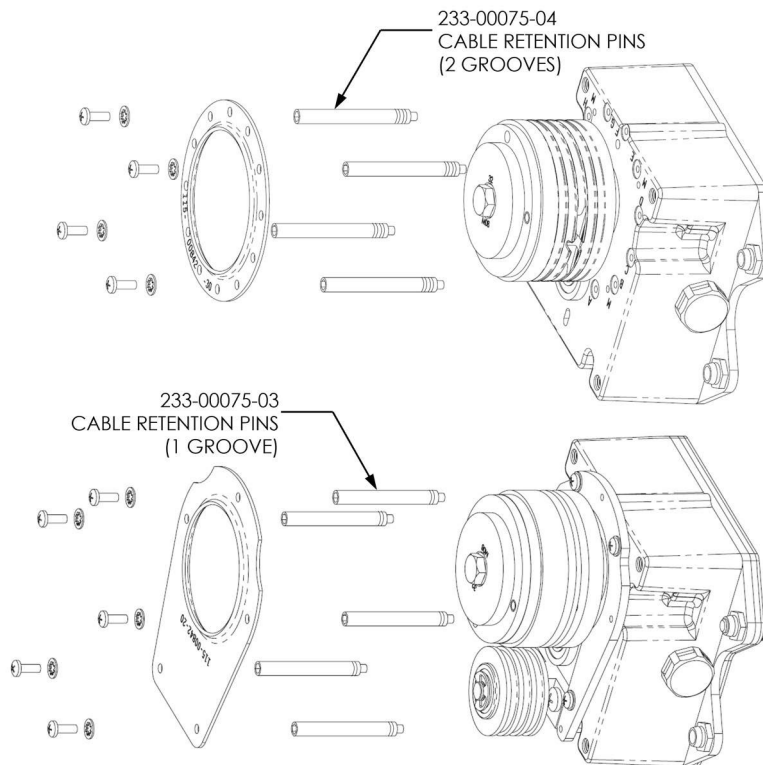

**Figure 4 - New Cable Retention Pins**

4. Make sure the same hole locations are used as the existing cable guard pins and torque to 6-8 in-lbs.
5. Install the removed cable guard hardware and torque screws to 6-8 in-lbs.