

TEMPORARY REVISION

AMM-TR-OÄM 42-398

Artex ELT 1000

This Temporary Revision AMM-TR-OÄM 42-398 is approved in conjunction with the Optional Design Change Advisory OÄM 42-398 and is valid in conjunction with the Airplane Maintenance Manual (AMM) until this Temporary Revision has been incorporated into the AMM.

The limitations and information contained herein either supplement or, in the case of conflict, override those in the AMM.

The technical information contained in this document has been approved under the authority of DOA No. EASA.21J.052.

Doc. No.	Section	Affected Pages
7.02.15	03-00-00	4b, 4bb
	05-00-00	3b, 3bb
	25-60-00	3a, 3aa, 207a, 207aa, 210a, 210aa, 211a, 211aa, 213a, 213aa
	92-00-00	1b, 1bb

Instruction

- Print this document double-sided on yellow paper (odd pages and "a" pages on front sides, even pages and "aa" pages on reverse sides).
- Insert this cover page as the first page of the AMM.
- Insert the other pages of this Temporary Revision in front of the corresponding AMM pages.

Intentionally left blank

AFFECTED CHAPTERS:

CHAPTER 03
GENERAL DESCRIPTION OF THE AIRPLANE

2. Equipment Data

The following item is amended to read:

ATA Chapter	Equipment/System	Manufacturer/Address	Direct Shipping Approved
25	Emergency Locator Transmitter (ELT):	ACR Electronics, Inc. 5757 Ravenswood Road Fort Lauderdale, Florida 33312 USA Website: www.acrartex.com	yes

Intentionally left blank

CHAPTER 05
TIME LIMITS AND MAINTENANCE CHECKS

G. Referenced Maintenance Data

The following item is added to the existing list:

Supplier	Document Name	Document No.
Artex	ELT 1000 Emergency Locator Transmitter Description, Operation, Installation and Maintenance Manual	Y1-03-0259

Intentionally left blank

CHAPTER 25
EQUIPMENT/FURNISHINGS
Section 25-60
Emergency Equipment

The following paragraph is amended to read:

3. Description of the Artex ME406 ELT and Artex ELT 1000

The ELT is located in the rear fuselage, below the aft baggage compartment. A velcro strap attached to a mounting bracket holds the ELT ME406 in position. A draw latch strap attached to a mounting bracket holds the ELT 1000 in position. The ELT antenna is mounted on the upper surface of the fuselage, above the ELT. A remote control panel/indicator (RPCI) is mounted on the instrument panel, right side.

The ELT transmits signals automatically after a crash on the emergency frequencies of 121.5 and 406 Megahertz (MHz). Every 50 seconds the transmitter transmits a signal on the 406 MHz frequency to a satellite. The signal to the satellite contains the serial number of the ELT transmitter or the airplane ID, a country code and a unique identity code. The satellite will also give the emergency services a more accurate location for the airplane.

The ELT has its own battery pack to supply electrical power. When the ELT is ON and transmitting the batteries will keep the ELT transmitting until battery power is gone on the 121.5 MHz frequency and for up to 24 hours on the 406 MHz frequency.

It is important to monitor the battery expiry dates for the battery pack. The expiry date for the battery pack is shown on the identity plate for the transmitter. The battery pack must be replaced when:

- After use in an emergency.
- After the transmitter has been accidentally switched ON for an unknown period of time.
- After 1 hour of accumulated use (testing).
- On or before the battery pack expiry date.

You must do regular functional tests. Refer to the Maintenance Practices in this Section.

Intentionally left blank

Maintenance Practices

The following procedure is amended read:

4. Remove/Install the Artex ME 406 or Artex ELT 1000 or Kannad 406 AF-Compact ELT or Kannad AF-Integra ELT

A. Remove the Artex ME 406 or Artex ELT 1000 or Kannad 406 AF-Compact ELT or Kannad AF-Integra ELT

	Detail Steps/Work Items	Key Items/References
(1)	Remove the access panel in the floor of the aft baggage compartment.	Refer to Section 25-50.
(2)	Disconnect these cables at the front of the ELT: – The coaxial cable. – The electrical cables.	At the bayonet connector. At the in-line connector.
(3)	Open the velcro strap. If Artex ELT 1000 (OÄM 42-398) is installed: Open the draw latch.	
(4)	Remove the ELT from the ELT mounting tray: – Lift the ELT from the mounting tray at the forward end. – Move the ELT forward and upward, clear of the mounting tray. – Move the ELT clear of the airplane.	

Intentionally left blank

The following figure is added:

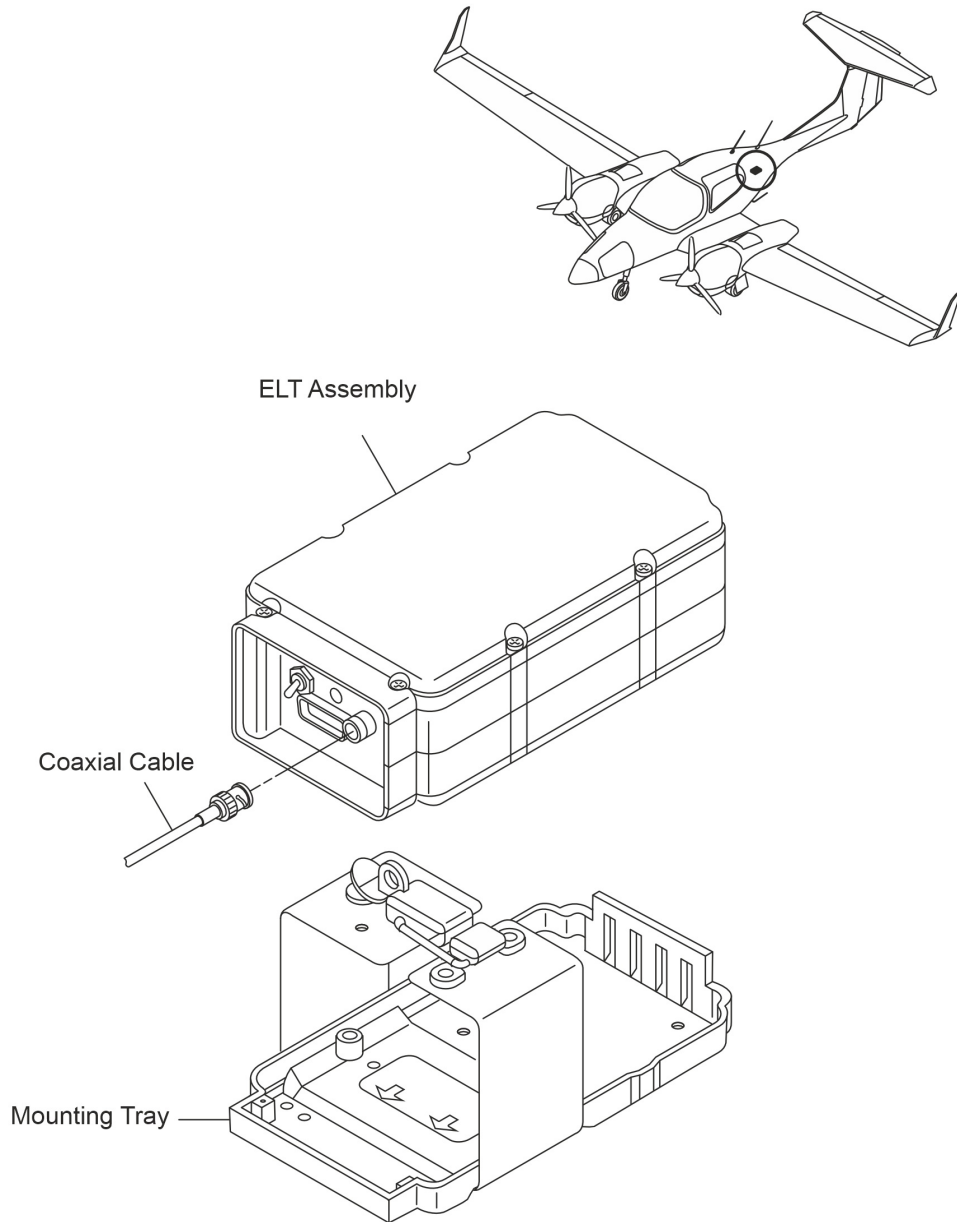

Figure 7: Artex ELT 1000 Installation

Intentionally left blank

The following procedure is amended read

B. Install the Artex ME406 or Artex ELT 1000 or Kannad 406 AF-Compact ELT or Kannad AF-Integra ELT

	Detail Steps/Work Items	Key Items/References
(1)	Make sure that the battery pack is serviceable and the battery expiration date is valid.	
(2)	<p>If the Artex ELT 1000 or Kannad AF-Integra is installed:</p> <p>Refer to the Initial Installation Manual.</p> <p>For the Artex ME 406 or the Kannad 406 AF Compact:</p> <p>Install the ELT into the mounting tray:</p> <ul style="list-style-type: none"> – Move the ELT into position at the mounting tray. – Make sure that the ON/OFF switch at the front of the ELT is set to OFF. – Lower the aft end of the ELT into the mounting tray so that the locking ‘ears’ at the aft end of the ELT engage with the slots in the mounting tray. – Lower the ELT fully into the mounting tray. 	Refer to Section 05-00.
(3)	Fasten the velcro strap around the ELT so that it is firmly held in place.	
(4)	Connect the electrical cables.	At the in-line connector.
(5)	Connect the coaxial cable.	At the bayonet connector.
(6)	Make sure that both the electrical cable connector and the coaxial bayonet connector are correctly located.	
(7)	Do a test for the correct operation of the ELT.	Refer to Paragraph 7 and/or the referenced Manuals in Section 05-00.

Intentionally left blank

The following headline is amended to read:

- 5. Replace the ELT Battery Pack of the Artex ME406 or the Artex ELT 1000

Intentionally left blank

CHAPTER 92
WIRING DIAGRAMS

1. General

The following item is amended to read:

Title	Drawing No.	Rev. No.	No. of Sheets
Schematic, ELT ME 406 / ELT 1000	D64-9225-60-02	A	1

Intentionally left blank