

TEMPORARY REVISION

AMM-TR-MÄM 42-1230

Bonding Wire

This Temporary Revision AMM-TR-MÄM-42-1230 is approved in conjunction with the Mandatory Design Change Advisory MÄM 42-1230 and is valid in conjunction with the Airplane Maintenance Manual (AMM) until this Temporary Revision has been incorporated into the AMM.

The limitations and information contained herein either supplement or, in the case of conflict, override those in the AMM.

The technical information contained in this document has been approved under the authority of DOA No. EASA.21J.052.

Doc. No.	Section	Affected Pages
7.02.15	27-00-00	5a, 5aa
	27-10-00	1a, 2a, 3a, 4a, 4b, 4bb, 5a, 6a, 205a, 205aa, 207a, 207aa
	27-50-00	2a, 2aa, 3a, 4a, 5a, 6a, 7a, 7aa, 201a, 202a, 206a, 206aa, 208a, 208aa, 212a, 212aa

Instruction

- Print this document double-sided on yellow paper (odd pages and "a" pages on front sides, even pages and "aa" pages on reverse sides).
- Insert this cover page as the first page of the AMM.
- Insert the other pages of this Temporary Revision in front of the corresponding AMM pages.



Intentionally left blank

CHAPTER 27
FLIGHT CONTROLS

Figure 2 is amended to read:

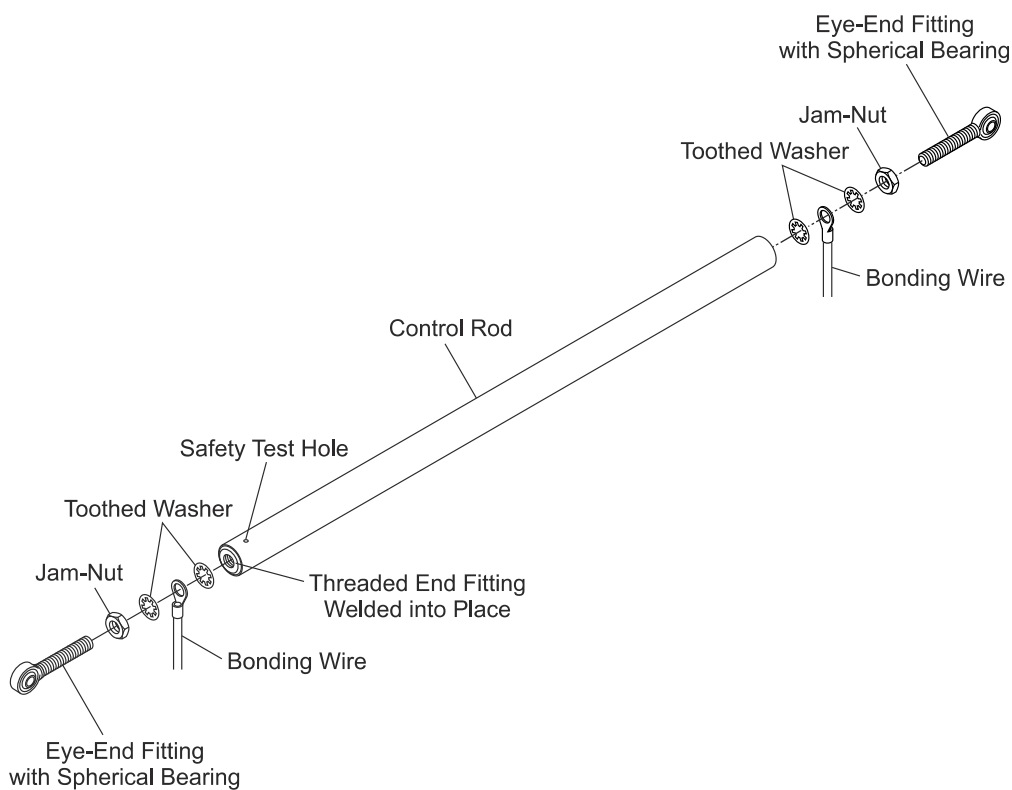

Figure 2: Typical Control Pushrod

Intentionally left blank

Section 27-10-00
Flight Control - Aileron and Tabs

1. General

The second paragraph is amended to read:

Figures 1, 2 and 3A show the aileron controls in the fuselage. Figure 3 shows the aileron controls in the wing.

Figure 1 is amended to read:

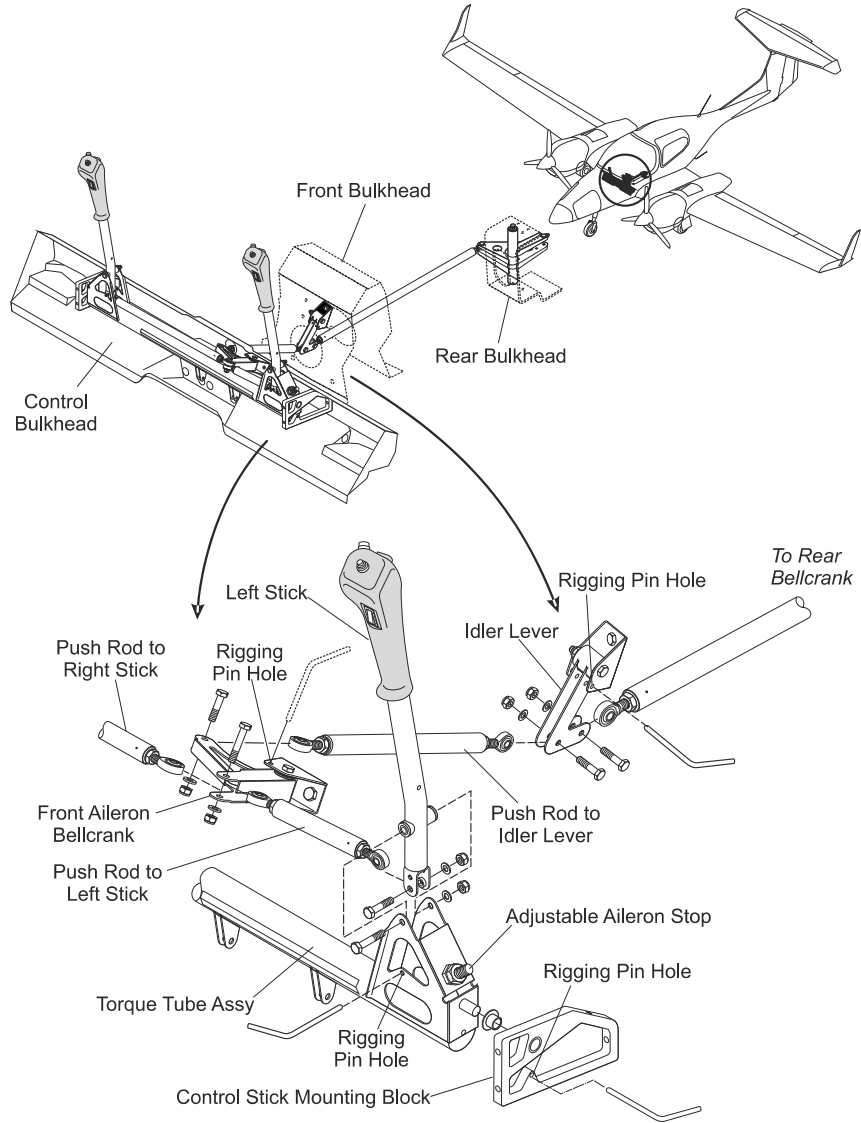

Figure 1: Aileron Controls in the Fuselage (Sheet 1)

Figure 2 is amended to read:

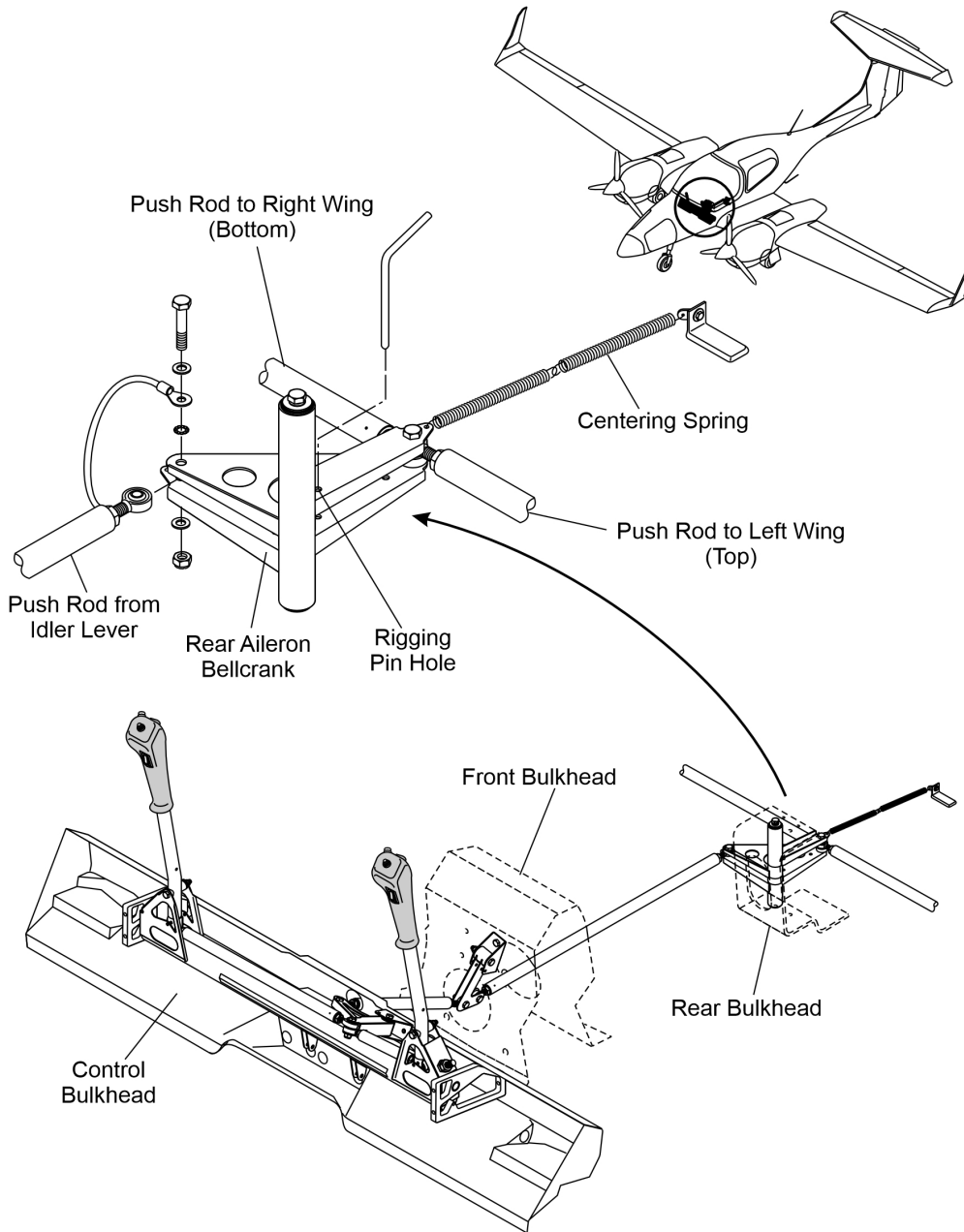

Figure 2: Aileron Controls in the Fuselage (Sheet 2)

Figure 3 is amended to read:

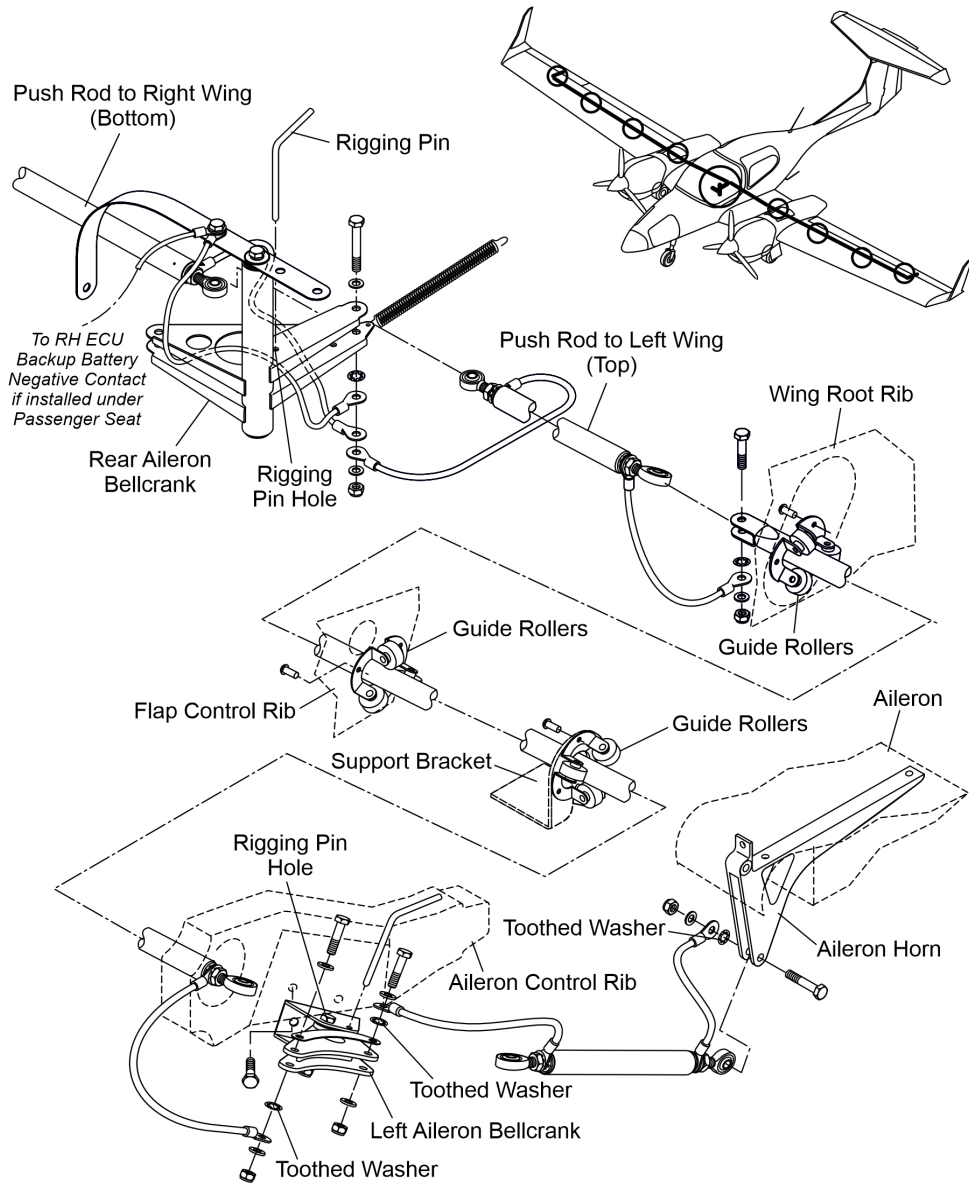

Figure 3: Aileron Controls in the Wing

Figure 3A is added:

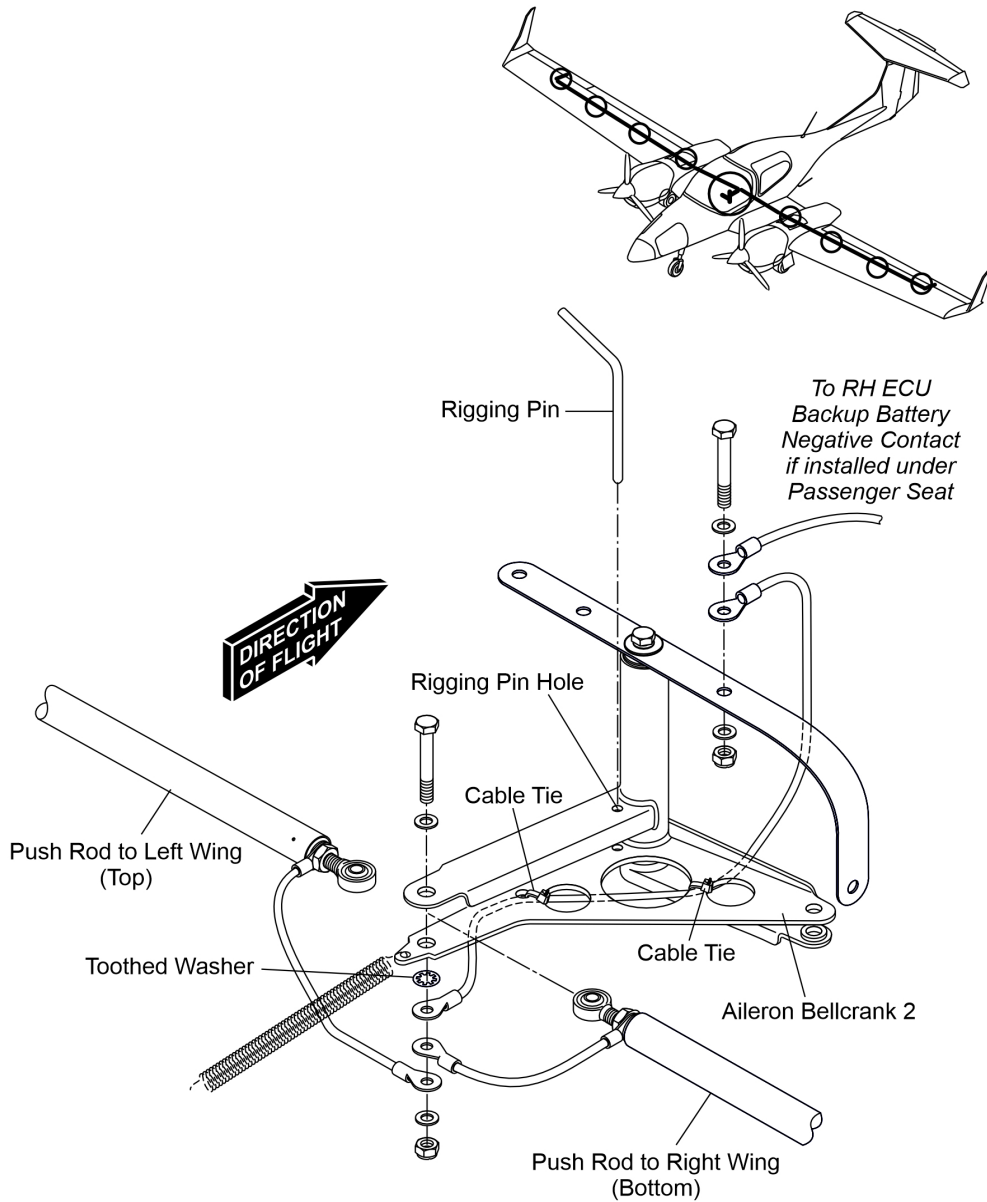

Figure 3A: Bonding Cables on Aileron Bellcrank

Intentionally left blank

The following paragraph is amended to read:

2. Description

The DA 42 NG has a control stick for each pilot. If OÄM 42-281 or OÄM 42-283 is installed, the RH control stick is removed or removable. The control sticks operate the ailerons and elevator via control rods. Aileron pushrods connect to the bottom of the control sticks. The pushrods connect to the front aileron bellcrank at the control bulkhead. The front aileron bellcrank at the control bulkhead connects to a short pushrod under the center console.

The short pushrod connects to an idler lever attached to the front main bulkhead. Another push-rod connects the idler lever to the rear aileron bellcrank. The rear aileron bellcrank attaches to the rear face of the rear main bulkhead.

The rear aileron bellcrank connects to the two pushrods in the center section. Each of these rods connect to long pushrod assemblies located in each of the wings.

Each long pushrod assembly has three pushrod guides. The first pushrod guide attaches to a rib located in the wing center section. The second attaches to the outer flap control rib. A small rib holds the third pushrod guide. The two long pushrod assemblies attach to the aileron bellcranks which are mounted in each wing, at the aileron control rib.

Short pushrods connect the aileron bellcrank to the aileron horn. You can adjust the short pushrods to move the aileron range-of-movement up or down.

The aileron stop which limits the movement of the control sticks to the right (right aileron up, left aileron down) is located to the left of the pilot's control stick (Figure 1). The aileron stop which limits the movement of the control stick to the left (left aileron up, right aileron down) is located to the right of the co-pilot's control stick. Each aileron stop consists of a nut which is welded to the torque tube assembly, a bolt which is installed in the nut and a jamnut which locks the assembly. The head of the bolt makes the stop.

Additional, non adjustable stops are located in front of the leading edge of the LH and RH aileron. Each stop consists of a GFRP block with a rubber coating, bonded to the inside of the upper wing skin. When the aileron is deflected fully downward, the aileron paddle is deflected fully upward and contacts the stop.

The following paragraph is amended to read:

3. Operation

If you move the control stick to the left:

- The pushrods connected to the stick move to the right.
- The front aileron bellcrank moves the pushrod below the center console towards the rear.
- The push-rod below the center console moves the idler lever and second short pushrod to the rear.
- The second short pushrod moves the rear aileron bellcrank so that the long pushrods in the wing move to the left.
- The left aileron bellcrank in the left wing moves the short pushrod attached to the left aileron horn to the rear.
- The left aileron moves up.

If you move the control sticks to the right:

- The left aileron moves down.
- The right aileron moves up.

Maintenance Practices

3. Aileron Control System Adjustments

B. Aileron Adjustment Procedure

The following items are amended to read:

	Detail Steps/Work Items	Key Items/References
	(2) Install rigging pins in the following: <ul style="list-style-type: none"> – The bottom of each control stick. – The left stick mounting bracket. – The front aileron bellcrank. – The idler lever. – The rear aileron bellcrank. – The left aileron bellcrank. – The right aileron bellcrank. 	Refer to Figures 1, 2, 3 and 3A. To lock the stick to the torque tube. To lock the elevator movement. On the control bulkhead. On the front main bulkhead. On the rear main bulkhead. In the left wing. In the right wing.
	(5) Remove the rigging pins from the following: <ul style="list-style-type: none"> – The bottom of each control stick. – The left stick mounting bracket. – The front aileron bellcrank. – The idler lever. – The rear aileron bellcrank. – The left aileron bellcrank. – The right aileron bellcrank. 	On the control bulkhead. On the front main bulkhead. On the rear main bulkhead. In the left wing. In the right wing.

Intentionally left blank

The following items are amended to read:

4. Aileron Pushrod Access

Aileron Pushrod	Remove/Install Access	References
Between the control stick and the front aileron bellcrank at the control bulkhead.	Pilot's seat.	Section 25-10.
Between the front aileron bellcrank at the control bulkhead and the idler lever at the front main bulkhead.	Pilot's seat.	Section 25-10.
Between the idler lever at the front main bulkhead and the rear aileron bellcrank at the rear main bulkhead.	Pilot's seat. Passenger seat.	Section 25-10.
Between the rear aileron bellcrank at the rear main bulkhead and the center section closing rib.	Passenger seat. Center section access panels.	Section 25-10. Section 52-40.
Between the center section closing rib and the aileron bellcrank in the left/right wing.	Center section access panels. Aileron bellcrank access panels under each wing.	Section 52-40.
Between the aileron bellcrank in the left/right wing and the ailerons.	Aileron bellcrank access panels under each wing.	Section 52-40.

5. Aileron Bellcrank and Lever Access

Aileron Bellcrank/Lever	Remove/Install Access	References
Front aileron bellcrank at the control bulkhead.	Pilot's seat.	Section 25-10.
Idler lever at the front main bulkhead.	Pilot's seat.	Section 25-10.
Rear aileron bellcrank at the rear main bulkhead.	Passenger seat.	Section 25-10.
Aileron bellcrank in the wing.	Aileron bellcrank access panels under each wing.	Section 52-40.

Intentionally left blank

Section 27-50-00
Flight Control - Flaps

Figure 1 is amended to read:

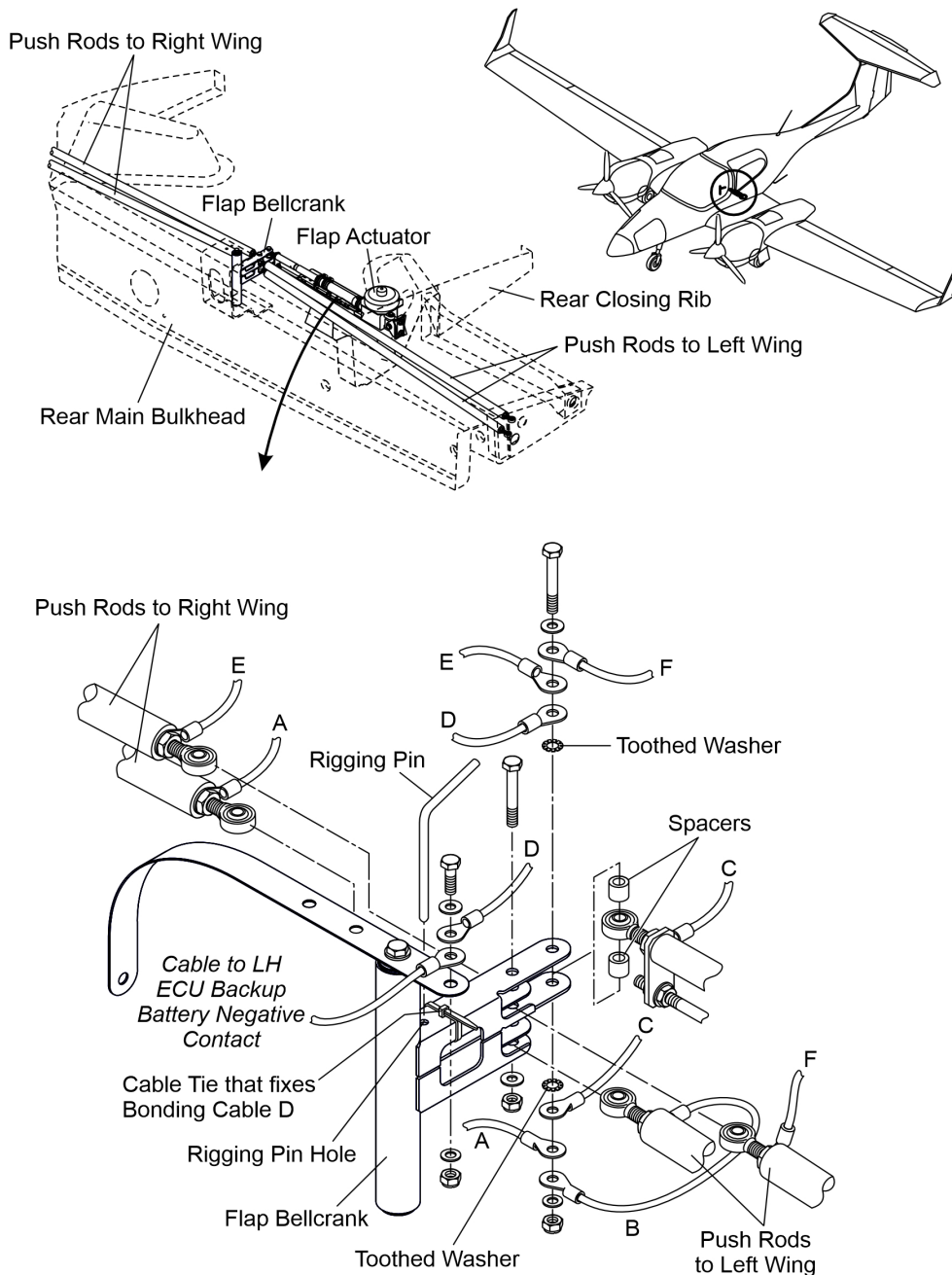

Figure 1: Flap Control System in the Fuselage

Intentionally left blank

The following paragraph is amended to read:

2. Description

Figure 1 shows the flap control system in the fuselage. Figure 2 shows the flap pushrods and flap bellcranks in the wing. Figure 3 shows the flap actuator installation.

A. Flap Actuator

An electric actuator operates the flaps. The electric actuator is under the left passenger seat. A mounting bracket on the left rear closing rib attaches the actuator to the structure.

The actuator has an electric motor. The motor has a reduction gear which turns a spindle. The spindle operates a pushrod. The pushrod connects to the flap bellcrank, that is attached to the rear main bulkhead.

A cam attached to the pushrod operates five micro switches. The micro switches are part of the flaps electronic control circuit.

B. Push-Rods and Bellcranks

The flap bellcrank on the rear main bulkhead connects to four pushrods. Two of the pushrods connect to the inboard ends of longer pushrods in the wing and the other two pushrods connect to the inner wing flap bellcranks. Two short pushrods connect the inner wing flap bellcranks to the inner flap horns.

The long pushrods connect to wing flap bellcranks in the outer wing. A guide bearing holds each long push-rod at the root rib. Two short pushrods connect the outer wing flap bellcranks to the flap horns.

Figure 2 is amended to read:

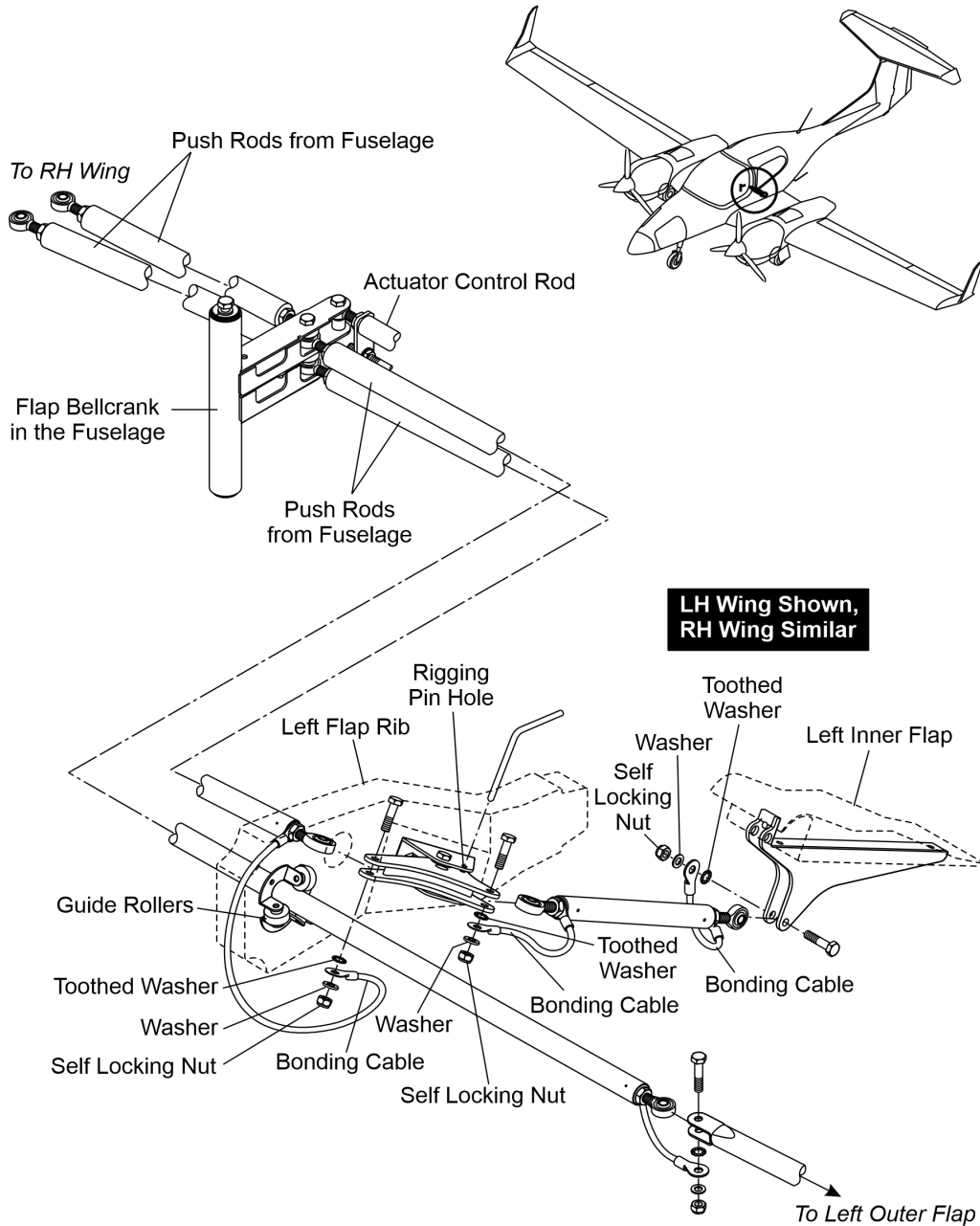

Figure 2: Flap Push-Rods and Bellcranks in the Wings

C. Flap Electrical Control

The following paragraph is amended to read:

The flap position indicator has three light emitting diodes. The top diode lights when the flaps are in the UP position. The middle diode lights when the flaps are in the APP position. The bottom diode lights when the flaps are in the LDG position.

Figure 3 is amended to read:

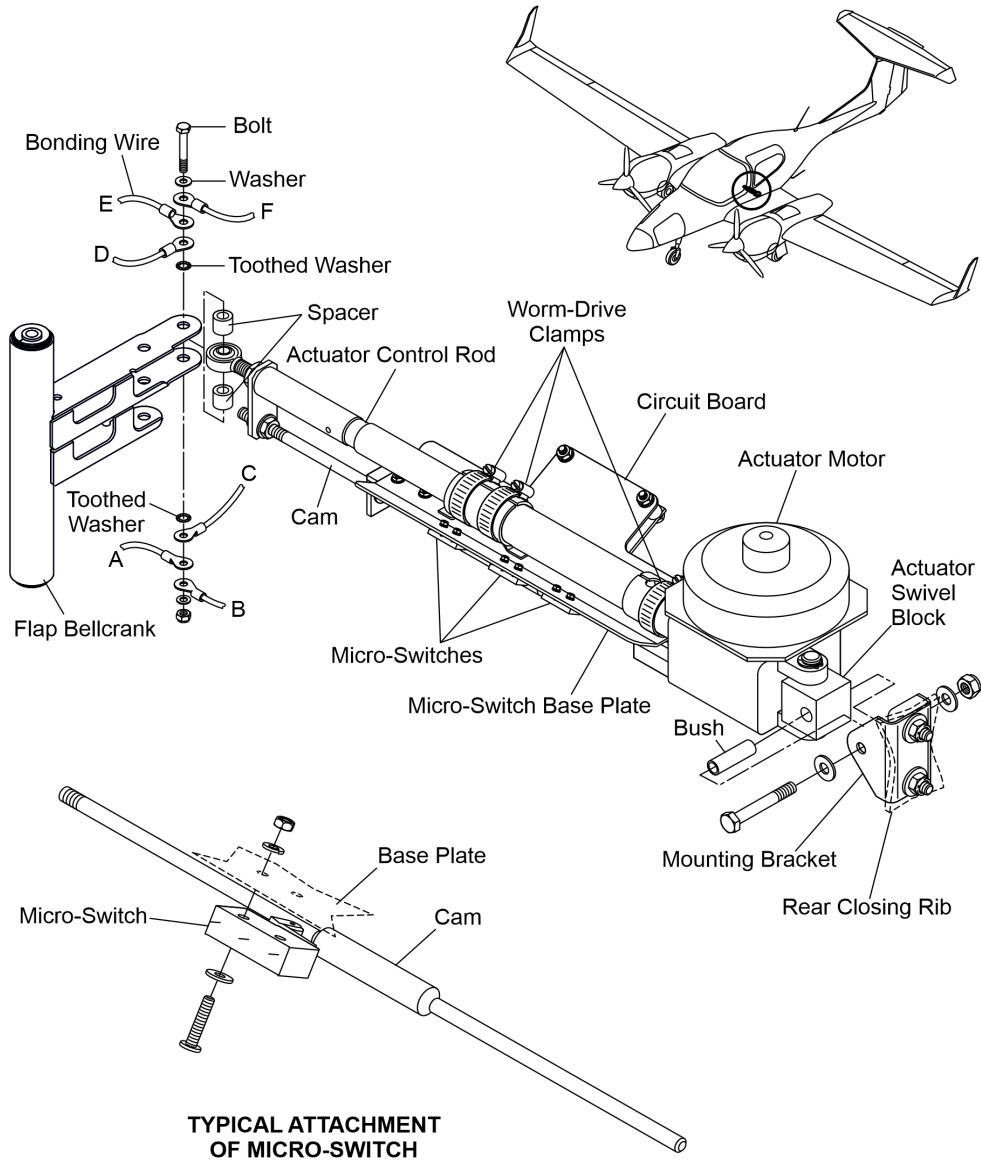

Figure 3: Flap Actuator Installation

The following paragraph is amended to read:

3. Operation

If you operate the flap selector switch these things happen:

- The switch energizes the related logic circuit.
- The logic circuit switches on the related transistors to supply power/ground to the flap motor.
- The flap motor turns the reduction gear and spindle. This moves the actuator pushrod towards the new set position.
- The push rod turns the flap bellcrank around its axis.
- The flap bellcrank moves the flap operating pushrods in the fuselage and the wings.
- The push-rods move the wing flap bellcranks in the left and right wings.
- The short pushrods move the flaps.

When the flap position reaches the position set by the flap selector:

- The cam on the flap actuator operates the related flap position and indication micro switches.
- The logic circuit switches off the related transistors to de-energize the flap motor.
- The flap position indicator shows the new flap position.

Intentionally left blank

Maintenance Practices

2. Remove/Install the Flap Actuator

A. Remove the Flap Actuator

The following item is amended to read:

	Detail Steps/Work Items	Key Items/References
I (6)	Remove the bolt which attaches the actuator pushrod to the flap bellcrank.	At the rear main bulkhead. Support the flaps.

B. Install the Flap Actuator

The following item is amended to read:

	Detail Steps/Work Items	Key Items/References
I	(3) Install the bolt which attaches the actuator push-rod to the flap bellcrank.	At the rear main bulkhead. Hold the flaps. Torque 6.4 Nm (4.7 lbf.ft.).

4. Adjust the Flap Control System

B. Adjust the Flap Control System

The following items are amended to read:

	Detail Steps/Work Items	Key Items/References
(2)	Remove these items for access: – The passenger seat. – The wing flap bellcrank access panels in both wings.	Refer to Section 25-10. Refer to Section 53-40.
(4)	Remove the bolt, spacers, washer and nut which attach the actuator push-rod to the flap bellcrank.	At the rear main bulkhead. Hold the flaps.
(5)	Put a rigging pin in the flap bellcrank.	Refer to Figure 3. At the rear main bulkhead.
(6)	Put a rigging pin in the left inner wing flap bellcrank in the left wing. If necessary adjust the push-rod between the flap bellcrank and the wing flap bellcrank.	Refer to Section 27-00.
(8)	Remove the rigging pins from the flap bellcrank and the wing flap bellcranks in the wings.	



Intentionally left blank

The following items are amended to read:

	Detail Steps/Work Items	Key Items/References
 	(16) Connect the flap actuator: – Install the bolt, spacers, washer and self-locking nut which attach the eye end to the flap bellcrank.	Torque 6.4 Nm (4.7 lbf.ft.).
	(21) Make sure that all the flaps hit the stops at the same time. If necessary, adjust the rod between the wing flaps bellcrank in the wing and the related flap.	Refer to Section 27-00.
	(24) Install these items: – The passenger seat. – The wing flap bellcrank panels in both wings.	Refer to Section 25-10. Refer to Section 53-40.



Intentionally left blank

The following items are amended to read:

5. Flap Push-Rod Access

Flap Pushrod	Remove/Install Access	References
Between the flap bellcrank at the rear bulkhead and the center section closing ribs.	Passenger seat. Center section access panels.	Section 25-10. Section 52-40.
Between the center section closing ribs and the inner wing flap bellcranks.	Passenger seat. Inner wing flap bellcrank access panels under each wing.	Section 25-10. Section 52-40.
Between the center section closing ribs and the outer wing flap bellcranks.	Passenger seat. Outer wing flap bellcrank access panels under each wing.	Section 25-10. Section 52-40.
Between the inner wing flap bellcranks and the inner flap horns.	Inner wing flap bellcrank access panels under each wing.	Section 52-40.
Between the outer wing flap bellcranks and the outer flap horns.	Outer wing flap bellcrank access panels under each wing.	Section 52-40.

6. Flap Bellcrank and Lever Access

Flap Pushrod	Remove/Install Access	References
Flap bellcrank at the rear main bulkhead.	Passenger seat.	Section 25-10.
Flap bellcranks in wings.	Inner and outer wing flap bellcrank access panels under each wing.	Section 52-40.



Intentionally left blank