

SUPPLEMENT S07

TO THE AIRPLANE FLIGHT MANUAL

DA 42 NG

Recirculating Air - Cabin Cooling

Doc. No. : 7.01.15-E

Date of Issue : 27 Apr 2011

Design Change Advisories : OÄM 42-204 & OÄM 42-193

This Supplement to the Airplane Flight Manual is EASA approved under Approval No. 10034803.

0.2 RECORD OF REVISIONS

Rev. No.	Reason	Chapter	Page(s)	Date of Revision	Approval Note	Date of Approval	Date Inserted	Signature
1	OÄM 42-193/d & OÄM 42-204/g	0, 3, 7	All	17-Sep-2012	Rev. 1 to AFM Supplement S07 to AFM Doc. No. 7.01.15-E is approved under the authority of DOA No. EASA 21J.052			
2	MÄM 42-659, MÄM 42-678, MÄM 42-759, OÄM 42-260, Corrections	0, 2, 5	9-S07-01, 9-S07-02, 9-S07-03, 9-S07-06, 9-S07-14	01-Apr-2014	Rev. 2 to AFM Supplement S07 to AFM Doc. No. 7.01.15-E is approved by EASA with Approval No.10048945.			

Doc. # 7.01.15-E	Rev. 2	01 Apr 2014	EASA approved	Page 9-S07-2
------------------	--------	-------------	---------------	--------------

0.3 LIST OF EFFECTIVE PAGES

Chapter	Page	Date
0	9-S07-1	01 Apr 2014
	9-S07-2	01 Apr 2014
	9-S07-3	01 Apr 2014
	9-S07-4	17 Sep 2012
1	9-S07-5	17 Sep 2012
2	EASA approved 9-S07-6	01 Apr 2014
3	9-S07-7	17 Sep 2012
4A	9-S07-8	17 Sep 2012
	9-S07-9	17 Sep 2012
	9-S07-10	17 Sep 2012
	9-S07-11	17 Sep 2012
	9-S07-12	17 Sep 2012
4B	9-S07-13	17 Sep 2012
5	9-S07-14	01 Apr 2014
6	9-S07-15	17 Sep 2012
7	9-S07-16	17 Sep 2012
	9-S07-17	17 Sep 2012
	9-S07-18	17 Sep 2012
	9-S07-19	17 Sep 2012
	9-S07-20	17 Sep 2012
8	9-S07-21	17 Sep 2012
	9-S07-22	17 Sep 2012

Doc. # 7.01.15-E	Rev. 2	01 Apr 2014	EASA approved	Page 9-S07-3
------------------	--------	-------------	------------------	--------------

0.4 TABLE OF CONTENTS

	Page
1. GENERAL	9-S07-5
2. OPERATING LIMITATIONS	9-S07-6
3. EMERGENCY PROCEDURES	9-S07-7
4A NORMAL OPERATING PROCEDURES	9-S07-8
4B ABNORMAL OPERATING PROCEDURES	9-S07-13
5. PERFORMANCE	9-S07-14
6. MASS AND BALANCE / EQUIPMENT LIST	9-S07-15
7. DESCRIPTION OF THE AIRPLANE AND ITS SYSTEMS	9-S07-16
8. AIRPLANE HANDLING, CARE AND MAINTENANCE	9-S07-21

1. GENERAL

This Supplement describes the function of the Recirculating Air - Cabin Cooling System and supplies all information for the safe and efficient operation of the system.

This Supplement is a permanent part of the AFM and must remain in the AFM at all times when the Recirculating Air - Cabin Cooling System is installed.

2. OPERATING LIMITATIONS

2.7 MASS (WEIGHT)

I Minimum flight mass : 1450 kg (3197 lb)

2.15 LIMITATION PLACARDS

On the Instrument Panel:

THE AUX POWER SWITCH MUST BE SWITCHED OFF IN ALL EMERGENCIES, DURING TAKE-OFF, LANDING , GO-AROUND OR ABNORMAL OPERATING PROCEDURES, AT AIR TEMPERATURES BELOW 10 °C (50 °F), ABOVE 10.000 ft MSLAND IF ADF IS IN USE.

2.16 OTHER LIMITATIONS

I 2.16.12 RECIRCULATING AIR - CABIN COOLING

The AUX POWER switch and the Recirculating Air - Cabin Cooling System must be switched OFF in all Emergencies, during Take-Off, Landing, Go-Around or Abnormal Operating Procedures, at outside air temperatures below 10 °C (50 °F, above 10.000 ft MSL and if ADF is in use.

The Recirculating Air - Cabin Cooling System adversely effects the accuracy of the ADF system (if installed) and the WX 500 stormscope (if installed). The AUX POWER switch must be switched OFF if the ADF system is used for navigation.

I Doc. # 7.01.15-E	Rev. 2	01 Apr 2014	EASA approved	Page 9-S07-6
--------------------	--------	-------------	------------------	--------------



■

3. EMERGENCY PROCEDURES

3.1 INTRODUCTION

3.1.1 GENERAL

CAUTION

The AUX POWER switch and the Recirculating Air - Cabin Cooling System must be switched OFF in all Emergencies, during Take-Off, Landing, Go-Around or Abnormal Operating Procedures, at Outside Air Temperatures below 10 °C (50 °F), above 10.000 ft MSL and if ADF is in use.

AUX POWER switch OFF

3.12.10 RECIRCULATING AIR - CABIN COOLING SYSTEM FAILURES

Smoke and Fire

AUX POWER switch OFF

Continue with 3.11 - SMOKE AND FIRE.

Excessive Noise or Vibration

AUX POWER switch OFF

4A NORMAL OPERATING PROCEDURES

4A.6 CHECKLISTS FOR NORMAL OPERATING PROCEDURES

CAUTION

The AUX POWER switch and the Recirculating Air - Cabin Cooling System must be switched OFF in all Emergencies, during Take-Off, Landing, Go-Around or Abnormal Operating Procedures, at Outside Air Temperatures below 10 °C (50 °F), above 10.000 ft MSL and if ADF is in use.

4A.6.1 PRE-FLIGHT INSPECTION

I. Cabin Check

Item a1) is added:

On the LH sidewall:

a1) AUX POWER switch check OFF

II. Walk-Around Check, Visual Inspection

4. Fuselage, left side, underside:

Items c1) and c2) are added:

c1) Cabin cooling air outlet visual inspection

c2) Cabin cooling air inlet visual inspection

6. Fuselage, right side:

Item a1) is added:

a1) Cabin cooling air inlet/outlet visual inspection

4A.6.2 BEFORE STARTING ENGINE

Item 10A is added:

10A. AUX POWER switch check OFF

4A.6.6 BEFORE TAKE-OFF

Item 9A is added:

9A. AUX POWER switch check OFF

4A.6.11 APPROACH & LANDING

Approach:

Item 3A is added:

3A. AUX POWER switch check OFF

4A.6.16 SHUT-DOWN

Item 4A is added:

4A. AUX POWER switch check OFF

**4A.6.22 RECIRCULATING AIR - CABIN COOLING SYSTEM GROUND
OPERATION**

Ground Operation with External Power Unit

NOTE

The External Power Unit must be capable to supply a minimum of 100 A at 28 V DC to operate the RACC - System.

1. POWER lever check IDLE
2. Parking brake set
3. AVIONIC MASTER check OFF
4. AUX POWER check OFF
5. ELECT. MASTER check OFF
6. ENGINE MASTER check OFF

CAUTION

When switching the External Power Unit ON, the electrically driven hydraulic gear pump may activate itself for 5 to 20 seconds in order to restore the system pressure. Should the pump continue to operate continuously or periodically, terminate flight preparation. There is a malfunction in the landing gear system.

NOTE

When switching the External Power Unit ON, all electrical equipment, connected to the LH and RH main buses is powered.

CONTINUED

Doc. # 7.01.15-E	Rev. 1	17 Sep 2012	Page 9-S07-11
------------------	--------	-------------	---------------

7. External power connect
8. Recirculating Air - Cabin Cooling switch ON
9. ELECT. MASTER ON

Ground Operation with Engine Running

1. AUX POWER switch ON
2. Recirculating Air - Cabin Cooling switch ON

Power Off

1. Recirculating Air - Cabin Cooling switch OFF
2. AUX POWER switch OFF

END OF CHECKLIST

4A.6.23 RECIRCULATING AIR - CABIN COOLING SYSTEM OPERATION IN FLIGHT

CAUTION

The AUX POWER switch and the Recirculating Air - Cabin Cooling System must be switched OFF in all Emergencies, during Take-Off, Landing, Go-Around or Abnormal Operating Procedures, at Outside Air Temperatures below 10 °C (50 °F), above 10.000 ft MSL and if ADF is in use.

Power On

1. AUX POWER switch ON
2. Recirculating Air - Cabin Cooling switch . . ON

Power Off

1. Recirculating Air - Cabin Cooling switch . . OFF
2. AUX POWER switch OFF

END OF CHECKLIST

4B ABNORMAL OPERATING PROCEDURES

CAUTION

The AUX POWER switch and the Recirculating Air - Cabin Cooling System must be switched OFF in all Emergencies, during Take-Off, Landing, Go-Around or Abnormal Operating Procedures, at Outside Air Temperatures below 10 °C (50 °F), above 10.000 ft MSL and if ADF is in use.

5. PERFORMANCE

CAUTION

The AUX POWER switch and the Recirculating Air - Cabin Cooling System must be switched OFF in all Emergencies, during Take-Off, Landing, Go-Around or Abnormal Operating Procedures, at Outside Air Temperatures below 10 °C (50 °F), above 10.000 ft MSL and if ADF is in use.

5.3.7 CLIMB PERFORMANCE

NOTE

The Rate of Climb with the Recirculating Air - Cabin Cooling System switched ON is reduced by 70 ft/min.

I 5.3.9 TIME, FUEL AND DISTANCE TO CLIMB

I NOTE

I Performance information not published for this airplane configuration.

I 5.3.10 CRUISE PERFORMANCE

NOTE

The Cruise Speed with the Recirculating Air - Cabin Cooling System switched OFF is reduced by 2 %.

NOTE

The Cruise Speed with the Recirculating Air - Cabin Cooling System switched ON is reduced by 5 %.



6. MASS AND BALANCE / EQUIPMENT LIST

No change.

7. DESCRIPTION OF THE AIRPLANE AND ITS SYSTEMS

7.15 RECIRCULATING AIR - CABIN COOLING SYSTEM

The Recirculating Air - Cabin Cooling System consists of the following main parts:

- AUX POWER switch and control panel (LH sidewall))
- Central unit (aft of the baggage compartment)
- Additional alternator (on the LH engine)

The Recirculating Air - Cabin Cooling System is not connected to the electrical system of the airplane. The additional alternator provides the electrical power to operate the Recirculating Air - Cabin Cooling System independently.

NOTE

The Recirculating Air - Cabin Cooling System effects the performance of the airplane. Refer to Chapter 5 of this Supplement.

Recirculating Air - Cabin Cooling Schematic

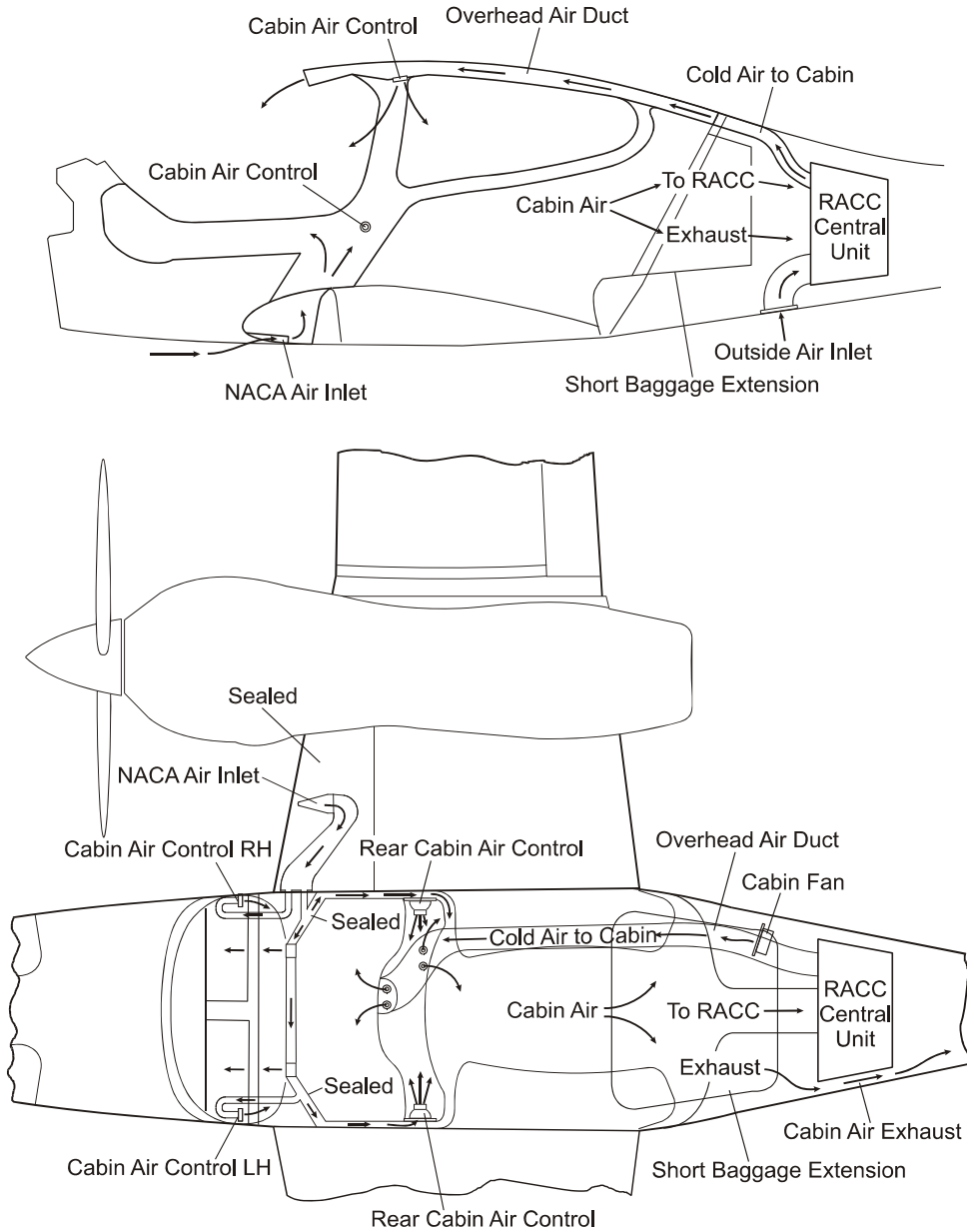

RACC System Schematic (if OÄM 42-193/c or earlier is installed)

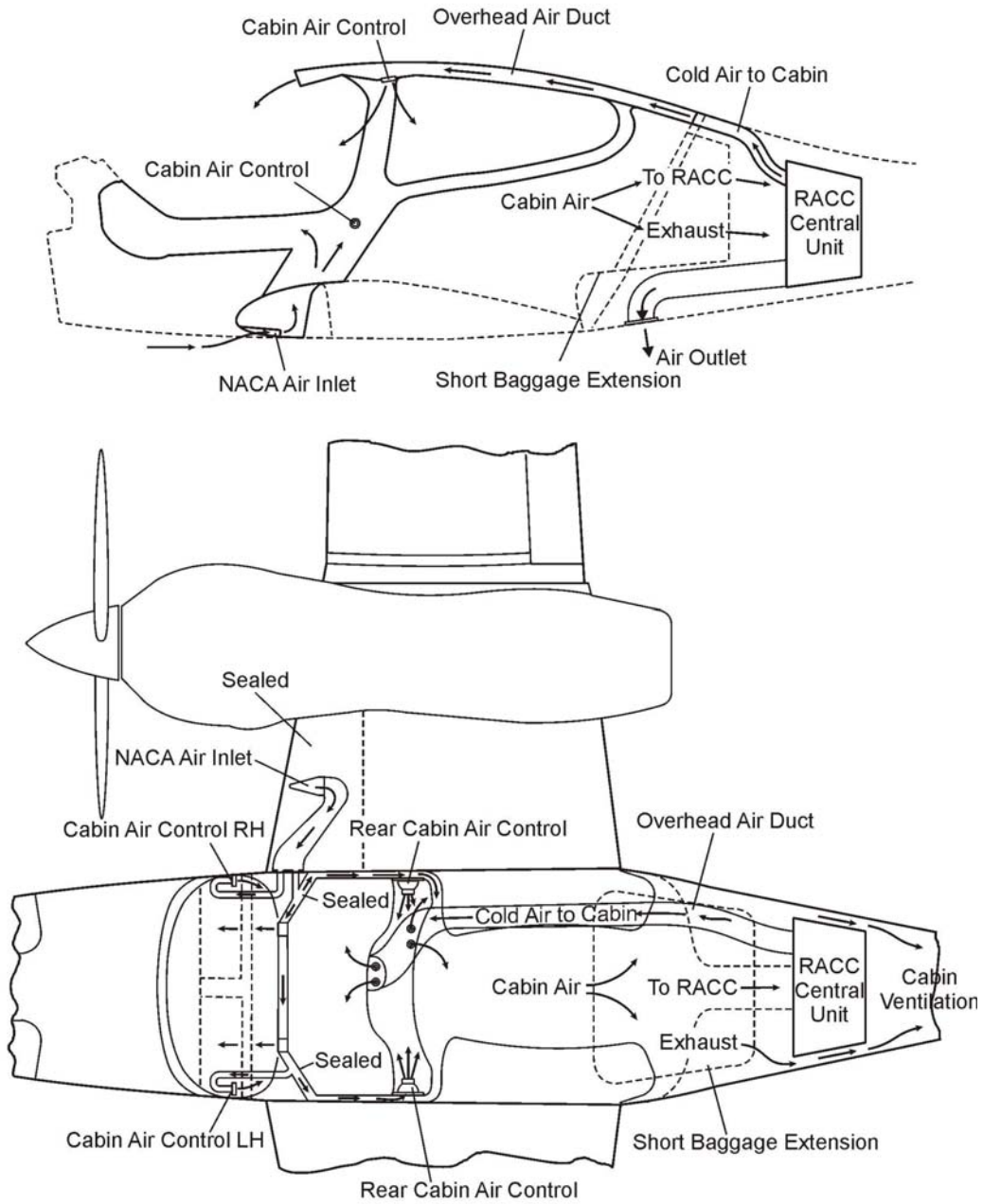

RACC System Schematic (if OÄM 42-193/d or later is installed)

Control Panel

The AUX POWER switch and the control panel are located on the LH sidewall. If the AUX POWER switch is set to ON, the Recirculating Air - Cabin Cooling System is electrically connected to the additional alternator which provides the electrical power for the system and the Power Status LED is flashing. To operate the Recirculating Air - Cabin Cooling System press the ON/OFF button once and wait until the display is permanently illuminated. The fan speed (three speed settings) is controlled with the UP and DOWN buttons to the left of the temperature display. The temperature preset buttons are located to the right of the temperature display. The preset cabin air temperature is shown on the temperature display in °F. If OÄM 42-193/d or later is installed, the temperature is shown in °C.

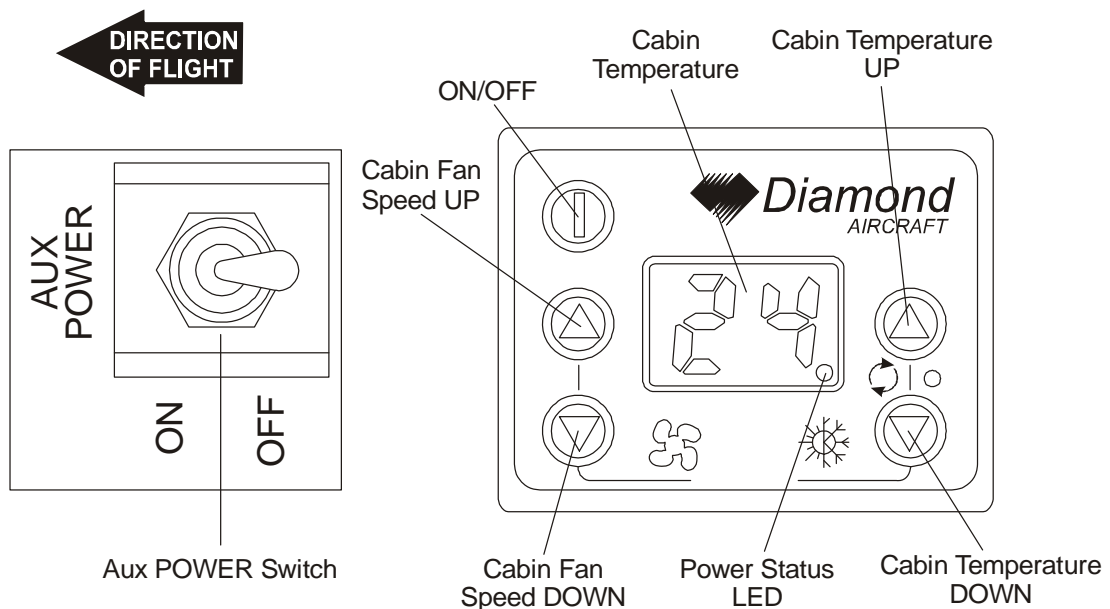

Central Unit

The central unit is located behind the passenger seats and the short baggage extension. It takes cabin air from the aft portion of the short baggage extension and recirculates it through the central unit and via the overhead air duct to the cooling air nozzles in the overhead panel. The central unit consists of an electrically driven compressor, heat exchangers, air inlets, air outlets and a control box. According to the preset cabin air temperature on the control panel, the control box operates the compressor and all essential control elements of the central unit in order to achieve the preset cabin air temperature.

Additional Alternator

The additional alternator is located at the front RH side of the LH engine next to the gearbox. The additional alternator is mounted to the engine via a single bolt at the bottom (this allows to rotate the alternator to tension the drive belt) and two bolts at the top which are connected to the engine gearbox via a bracket. A pulley is installed on a drive disc at the propeller shaft which drives the additional alternator via a V-belt. Connected to the propeller drive disc is an axial fan to provide engine gearbox cooling.

If the AUX POWER switch is set to ON, the additional alternator provides the electrical power for the Recirculating Air - Cabin Cooling System.

8. AIRPLANE HANDLING, CARE AND MAINTENANCE

No change.

Intentionally left blank.