

SERVICE INFORMATION NO. SI D4-108

NOTE: SI's are used **only**:

- 1) To distribute information from DAI to our customers.
- 2) To distribute applicable information / documents from our suppliers to our customers with additional information.

Typically there is no revision service for SI's. Each new information or change of that will be sent along with a new SI.

I. TECHNICAL DETAILS

1.1 Airplanes affected:

All DA 40 D aircraft equipped with GARMIN G1000 System.

1.2 Subject:

GARMIN Service Alert No. 0824
ATA-Code: 34-00

1.3 Reason:

GARMIN has identified an issue, whereby the large (outer) BARO knob and the small (inner) CRS knob may interfere with each other. The Service Alert No. 0824 contains instructions on how to test for knob interference.

1.4 Information:

For detailed technical information refer to the GARMIN Service Alert No. 0824 which is applicable without any further additions or restrictions.

II. OTHERS

The GARMIN Service Alert No. 0824 is attached to this SI.

In case of doubt contact Diamond Aircraft Industries GmbH.



**** MANDATORY **
SERVICE BULLETIN**

NO.: 0823

TO: All Garmin Aviation Service Centers

DATE: 10 July 2008

SUBJECT: GDU 104X CRS/BARO Knob Interference

PURPOSE

Garmin has identified an issue, whereby the large (outer) BARO knob and the small (inner) CRS knob may interfere with each other.

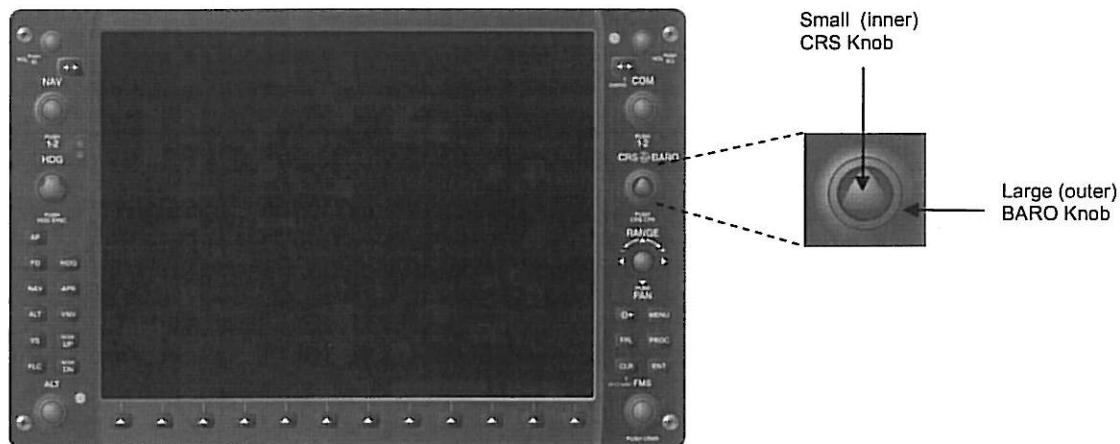

Figure 1

DESCRIPTION

This service bulletin contains instructions on how to test for knob interference and remove/replace the CRS/BARO knobs, as required.

© Copyright 2008
Garmin Ltd. or its subsidiaries
All Rights Reserved

Except as expressly provided herein, no part of this document may be reproduced, copied, transmitted, disseminated, downloaded or stored in any storage medium, for any purpose without the express prior written consent of Garmin. Garmin hereby grants permission to download a single copy of this document and of any revision to this document onto a hard drive or other electronic storage medium to be viewed and to print one copy of this document or of any revision hereto, provided that such electronic or printed copy of this document or revision must contain the complete text of this copyright notice and provided further that any unauthorized commercial distribution of this document or any revision hereto is strictly prohibited.

AFMS AND PILOT'S GUIDE CONSIDERATIONS

There are no changes to AFMS documents that are relative to this Service Bulletin.

There are no Pilot's Guide changes relative to this Service Bulletin.

PRODUCT AFFECTED

All G1000/G900X/G950 installations with the following 10-inch GDU 104X displays are affected:

GDU 1040 011-00972-00, 011-00972-02, 011-00972-03
GDU 1042 011-01080-00
GDU 1043 011-01079-00
GDU 1044 011-01078-01
GDU 1044B 011-01274-00
GDU 1045 011-00819-04

The following G1000-equipped aircraft include one or more of the affected GDU 104X displays listed above.

Cessna 172R/172S/182T/T182T/206H/T206H
Cessna 350/400
Columbia 350/400
Diamond DA40/40F/40D/DA42
Mooney M20M/M20R/M20TN
Piper PA 32 Saratoga
Quest Kodiak 100
Hawker Beechcraft G36 Bonanza
Hawker Beechcraft G58 Baron
Tiger AG-5B

All G900X/G950 aircraft installations are affected by this bulletin.

COMPLIANCE

Compliance with this service bulletin is **MANDATORY**.

MANPOWER

30 minutes labor including testing, per aircraft.

WARRANTY INFORMATION

This modification is warranty reimbursable for the manpower listed above when knob interference is confirmed and knobs have been replaced.

TESTING PROCEDURE

PFD and MFD CRS/BARO Knob Interference Test

1. Apply power to the G1000/G900X/G950.
2. Press the CDI softkey on the Primary Flight Display(s) (PFD) to enter VOR mode on the HSI.
3. Rotate the large (outer) BARO knob (refer to Figure 1) a minimum of three complete revolutions in each direction while monitoring the Horizontal Situation Indicator/Digital Course Indicator (refer to Figure 2) on the PFD. If a change in the Horizontal Situation Indicator/Digital Course Indicator is produced while turning the BARO knob proceed to the Modification Instructions.

NOTE

In some installations the Digital Course Indicator does not display unless the field is actively being edited. In these instances, if the Digital Course Indicator does not appear while turning the BARO knob, no interference is present.

4. Rotate the small (inner) CRS knob (refer to Figure 1) a minimum of three complete revolutions in each direction while monitoring the Barometric Altimeter Setting (refer to Figure 2) on the PFD. If a change in the Barometric Altimeter Setting is produced while turning the CRS knob proceed to the Modification Instructions.
5. Repeat Steps 3 and 4 for each affected GDU.

NOTE

When testing the Multi Function Display (MFD), the indications must be monitored on the PFD.

6. If no interference is confirmed, proceed to Step 12 of the MODIFICATION INSTRUCTIONS.

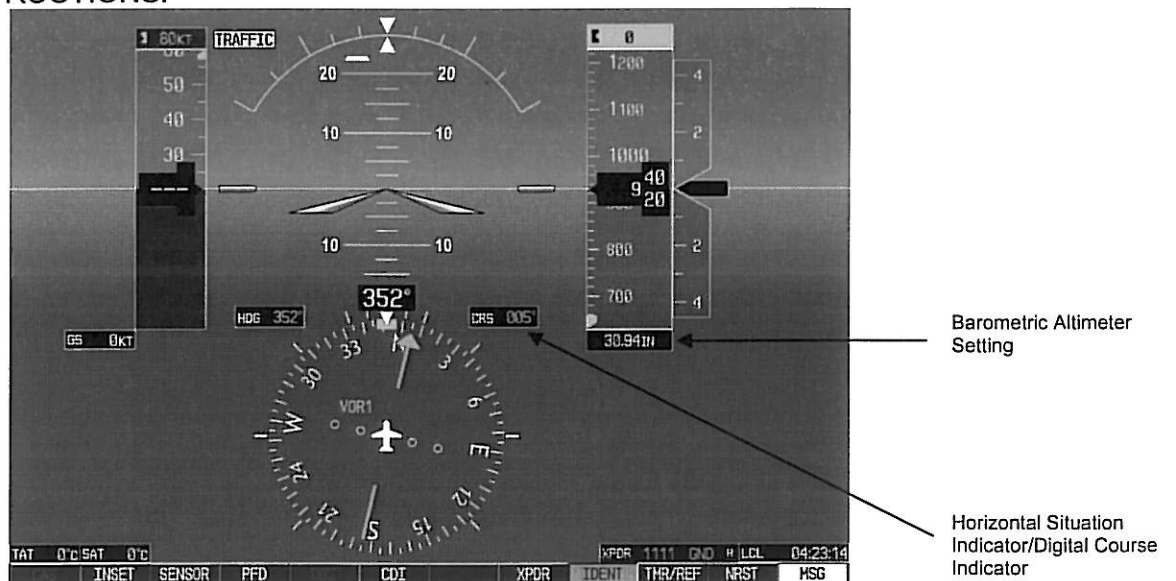

Figure 2

MODIFICATION INSTRUCTIONS

If CRS/BARO Knob interference is confirmed, perform the steps below to replace the CRS/BARO Knob. New knobs can be obtained through a Garmin Service Center or Aircraft OEM under Garmin part number K00-00446-00.

1. Grasp the small (inner) CRS knob and firmly pull the knob off the shaft.
2. Discard knob.
3. Grasp the large (outer) BARO knob and firmly pull the knob off the shaft.
4. Discard knob.

NOTE

Once both knobs have been discarded, new knobs can be installed.

5. Grasp the large (outer) BARO knob (insuring proper orientation) and place it over the shaft.
6. Align the flat side of the knob insert with the flat side of the shaft.
7. Press down firmly to ensure knob is completely seated, refer to Figure 3.
8. Grasp the small (inner) CRS knob (insuring proper orientation) and place it over the shaft.
9. Align the flat side of the knob insert with the flat side of the shaft.
10. Press down firmly to ensure knob is completely seated, refer to Figure 3.
11. Perform the CRS/BARO Knob Interference Test (contained in the TESTING PROCEDURE section) again to confirm there is no interference.
12. Accomplish aircraft logbook entry to return aircraft to service in compliance with this service bulletin.

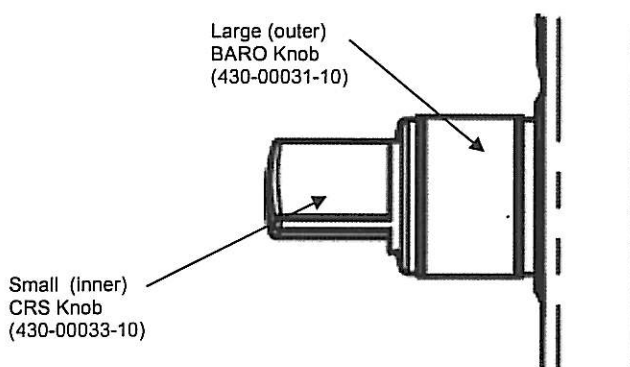

Figure 3

MATERIAL INFORMATION

QTY	Part Number	Description
1 per affected GDU	K00-00446-00	GDU CRS/BARO Knob Replacement