

## SERVICE INFORMATION NO. SI 40-035

## SERVICE INFORMATION NO. SI D4-050

**NOTE:** SI's are used **only**:  
1) To distribute information from DAI to our customers.  
2) To distribute applicable information / documents from our suppliers to our customers with additional information.  
Typically there is no revision service for SI's. Each new information or change of that will be send along with a new SI.

### I. TECHNICAL DETAILS

#### 1.1 Airplanes affected:

All DA 40      aircraft with GTX 330/GTX 330 D installed and the G1000 not installed  
All DA 40D    aircraft with GTX 330/GTX 330 D installed and the G1000 not installed

#### 1.2 Subject:

Garmin GTX 330/GTX 330 D new Software Version  
ATA-Code:    34-00

#### 1.3 Reason:

Garmin has issued a new Service Bulletin regarding the GTX 330/GTX 330 D.

#### 1.4 Information:

For detailed technical information see Garmin Service Bulletin which is applicable without any further additions or restrictions.

### II. OTHERS

The Service Bulletin No.: 0543 of Garmin is attached to this SI.

In case of doubt contact Garmin or Diamond Aircraft Industries.



## SOFTWARE SERVICE BULLETIN

NO.: 0543

**TO:** All Garmin Aviation Service Centers

**DATE:** 2 March 2006

**SUBJECT:** GTX 330/330D, GTX 33/33D Software Upgrade to Version 4.04 for non-G1000 applications only

---

\*Note: The term GTX 330 applies to both GTX 330 Mode S Transponders and GTX 330D Diversity Mode S Transponders unless otherwise stated. Likewise, the term GTX 33 applies to both GTX 33 Mode S Transponders and GTX 33D Diversity Mode S Transponders unless otherwise stated.

### **PURPOSE**

This Software Service Bulletin incorporates new unit Software Version 4.04 for the GTX 330 and GTX 33.

Software version 4.04 provides the following enhancement:

- When entering a transponder code the unedited portions are dashed out. If the transponder code is not completely entered within a timely matter, the code will revert to display the previously set value.

### **DESCRIPTION**

This modification consists of uploading new software to the unit using a Garmin supplied diskette, P/N A00-10113-12. (Note: requires Windows.)

### **APPROVAL**

TSO C112 Class 2A

The Engineering data contained in GTX 330/33 Software Version 4.04 are FAA approved. This change is a minor software change.

### **AFMS AND PILOT'S GUIDE CONSIDERATIONS**

There are no recommended AFMS changes.

GTX 330 Pilot's Guide, P/N 190-00207-00, Rev. C or later.

## **PRODUCT AFFECTED**

All GTX 330/GTX 33 units with Software Version 4.03 or previous software versions. The unit's current software version is displayed at power up, on either the GTX 330 front panel or the GNS 480 (CNX80) screen for the GTX 330/33.

## **COMPLIANCE**

**Optional:** This service bulletin may be incorporated in GTX 330/33 units that do not have Software Version 4.04, at the customer's request.

## **REFERENCES**

GTX 330 Installation Manual, P/N 190-00207-02, Rev. K or later, GTX 33 Installation Manual, P/N 190-00303-61, Rev. E or later.

## **MANPOWER**

One-hour (1.0) labor including testing.

## **WARRANTY INFORMATION**

This modification is not warranty reimbursable.

## **MODIFICATION INSTRUCTIONS FOR UPGRADING TO SOFTWARE VER. 4.04**

The procedures described below are for the software field upgrade only.

1. Use a test harness for the GTX 330/GTX 33 as shown in the following figure:

### **CAUTION**

If the unit is removed from the aircraft and operated, always connect J3302, (J3303 for GTX 330D/GTX 33D) to an antenna or a 50  $\Omega$ , 5-watt load. The GTX 330/GTX 33 transmits Mode S acquisition squitter replies once per second whether interrogations are received or not. Failure to connect a dummy load during this procedure will cause the transponder to fail.

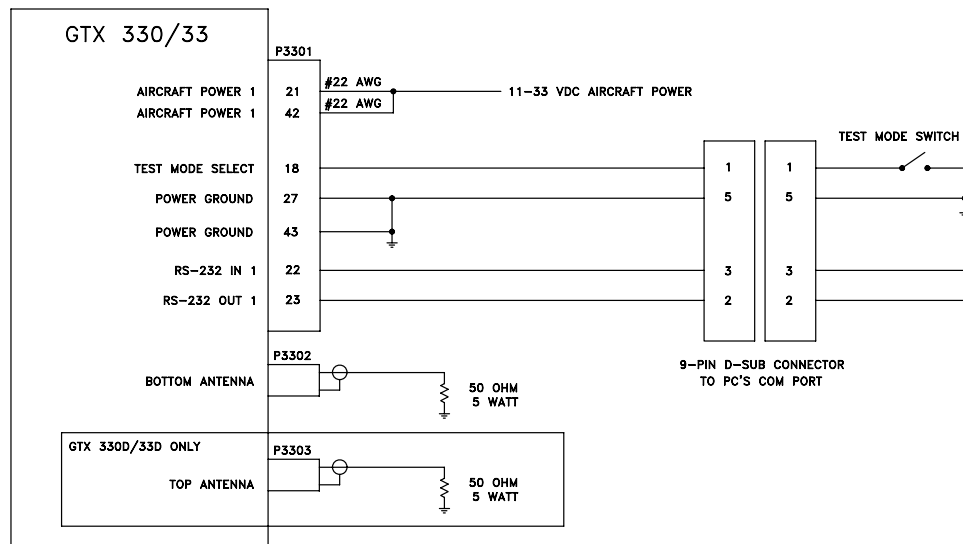

2. Ensure that the unit is turned off. Connect the GTX 330/GTX 33 to the test harness and apply power to the harness.
3. With the unit off, enable test mode via the Test Mode Switch. (Applies a ground to P3301 pin 18).
4. At the Computer's DOS prompt, copy the files from the diskette, P/N A00-10113-12 into a directory on the Computer's Hard Disk Drive using the following command lines:  

```
C:  
MD C:\GARMIN  
CD C:\GARMIN  
A:330UPD12 (note these are zeros)
```
5. Connect the 9-pin D-Sub connector of the test harness to a free serial port (COM 1 or 2) on the PC and apply power.
6. Turn the GTX 330 unit on. (The GTX 33 will turn on by the application of power.) The GTX 330 unit will be in test mode and show a dynamic test screen.

7. From the DOS prompt, in the directory from which you copied the files (e.g., C:\GARMIN), run the update program using the following command line:  
AVXRGN32 /R4 /Fhex 006B0172.01P (note: these are zeros, observe exact character string including spacing).
8. During the software upload, the GTX 330 unit display test pattern either becomes static or the display will blank, depending on the software version originally installed in the unit. The upload process could take up to 5 minutes to complete; the unit will reset itself, turn on, and show a dynamic display test screen.
9. Turn the unit off and disable test mode via the test mode switch.
10. Turn the unit on and verify the new Software Version 4.04 on the GTX 330 Startup/Self-Test Page. Verify the new Software Version 4.04 for the GTX 33 on the GNS 480 (CNX80) display.

## **MODIFICATION INSTRUCTIONS FOR BACKLOADING TO SOFTWARE VER. 4.03**

**This special use diskette provides a means to return a version 4.04 unit to Software Version 4.03, should the need arise.**

1. Assemble a test harness for the GTX 330/GTX 33 as shown in the previous figure.
2. Ensure that the unit is turned off. Connect the GTX 330/GTX 33 to the test harness and apply power to the harness.
3. With the unit off, enable test mode via the test mode switch. (Applies a ground to P3301 pin 18).
4. At the Computer's DOS prompt, copy the files from diskette, P/N A00-10113-11, into a directory on the Computer's Hard Disk Drive using the following command lines:  
C:  
MD C:\GARMIN  
CD C:\GARMIN  
A:330UPD11 (note these are zeros)
5. Connect the 9-pin D-Sub connector of the test harness to a free serial port (COM 1 or 2) on the PC and apply power.
6. Turn the GTX 330 unit on. (The GTX 33 will turn on by the application of power.) The GTX 330 unit will be in test mode and show a dynamic test screen.
7. From the DOS prompt, in the directory from which you copied the files (e.g., C:\GARMIN), run the update program using the following command line:  
AVXRGN32 /R4 /Fhex 006B0172.01N (note these are zeros, observe exact character string including spacing).
8. During the software upload, the unit's display test pattern either becomes static or the display will blank, depending on the software version originally installed in the unit. The upload process could take up to 5 minutes to complete; the unit will reset itself, turn on, and show a dynamic display test screen.
9. Turn the unit off and disable test mode via the test mode switch.
10. Turn the unit on and verify the Software Version 4.03 on the GTX 330 Startup/Self-Test Page. Verify the Software Version 4.03 for the GTX 33 on the GNS 480 (CNX80) display.

## **TESTING PROCEDURE**

The unit's built-in Self-Test is adequate to return the appliance to service.

## **IDENTIFICATION PROCEDURE**

The unit's current software version is viewed at power up as indicated in the last step of the MODIFICATION INSTRUCTIONS.

## **MATERIAL INFORMATION**

All parts required to modify multiple GTX 330 and GTX 33 units per this Service Bulletin are listed below:

QTY	Part Number	Description
1	A00-10113-12	Diskette, GTX 330/GTX 33, Software Version 4.04
1	A00-10113-11	Diskette, GTX 330/GTX 33, Software Version 4.03

A connector kit is available to construct the test harness if required:

QTY	Part Number	Description
1	011-00583-00	GTX 330/GTX 33 Connector kit

## **ADDITIONAL INFORMATION**

None.