

OPTIONAL SERVICE BULLETIN

OSB 40-061/1
OSB D4-067/1
OSB F4-017/1
OSB 40NG-044

I TECHNICAL DETAILS

1) Category

Optional.

2) Airplanes affected

Type: DA 40, DA 40 D, DA 40 F, DA 40 NG
Serial Numbers: 40.006 through 40.084
40.201 through 40.599
D4.001 through D4.185
40.FC001 through 40.FC009

3) Date of Effectivity

03-Mar-2009.

4) Time of Compliance

At owner's discretion.

5) **Subject**

This OSB introduces 4 maintenance access holes in the elevator, 2 beside each intermediate hinge, to allow for replacement of the bearing. The holes will be closed with plugs.

ATA-Code: 55-20 Elevator

6) **Reason**

Maintenance Access holes for simplified maintenance and replacement of the plain bearings, which serve as intermediate hinges of the elevator, have been introduced to the serial production. Those access holes are made available for retrofit to DA 40 aircraft delivered prior to this design change.

7) **Concurrent Documents**

None.

8) **Approval**

The technical information or instructions contained in this document relate to the Design Change Advisories No. MÄM 40-181 and VÄM 40-004, which have been approved under the authority of EASA Design Organization Approval ref. EASA.21J.052 and by EASA.

The technical content of this document has been approved under the authority of DOA ref. EASA.21J.052.

9) **Accomplishment/Instructions**

Comply with Work Instruction No. WI-OSB 40-061 / WI-OSB D4-067 / WI-OSB F4-017 / WI-OSB 40NG-044, latest effective issue.

10) **Mass (Weight) and CG**

Weighing of mass and static balance of the elevator is mandatory. Refer to AMM Section 51-60 Control Surface Balancing.

II PLANNING INFORMATION

1) Material & Availability

See WI-OSB 40-061 / WI-OSB D40-067 / WI-OSB F4-017 / WI-OSB 40NG-044, latest effective issue.

2) Special Tools

Ring saw Ø 25 mm (1 inch).

3) Labor Effort

Approx. 3 hours.

4) Credit

None.

5) Reference Documents

DA 40 Series Airplane Maintenance Manual Doc. No. 6.02.01, latest effective issue.

DA 40 NG Airplane Maintenance Manual Doc. No. 6.02.15, latest effective issue.

III REMARKS

- 1) All work must be done by a certified aircraft maintenance station or a certified aircraft maintenance mechanic.
- 2) All work, in particular that which is not especially described in this service bulletin, must be done in accordance with the referenced maintenance manual.
- 3) Completion of all work must be confirmed in the log book.
- 4) In case of doubt, contact Diamond Aircraft Industries GmbH.



Diamond Aircraft Industries GmbH
N. A. Otto-Straße 5
2700 Wiener Neustadt, Austria

DAI OSB 40-061/1
DAI OSB D4-067/1
DAI OSB F4-017/1
DAI OSB 40NG-044
Page 4 of 4
03-Feb-2016

EXECUTION REPORT TO SERVICE BULLETIN

OSB 40-061/1

OSB D4-067/1

OSB F4-017/1

OSB 40NG-044

AIRPLANE DATA

Airplane Serial Number: _____

Airplane Registration: _____

Airplane Operator: _____

Hours of operation of airplane: _____

No. of landings: _____

Hours of operation-engine: _____

Typical operation of airplane: private, club, training, other _____

Date, Name, Sign

Please fax the completed form to Fax No. +43-2622-26700-1369 or e-mail to
airworthiness@diamond-air.at

WORK INSTRUCTION

WI-OSB 40-061

WI-OSB D4-067

WI-OSB F4-017

WI-OSB 40NG-044

I GENERAL INFORMATION

I.1 Subject

This OSB introduces 4 maintenance access holes in the elevator, 2 beside each intermediate hinge, to allow replacement of the bearing. The holes will be closed with plugs.

I.2 Reference Documents

DA 40 Series Airplane Maintenance Manual, Doc. No. 6.02.01, latest effective issue.

DA 40 NG Airplane Maintenance Manual, Doc. No. 6.02.15, latest effective issue.

I.3 Remarks

- a) All work must be done by a certified aircraft service station or a certified aircraft maintenance mechanic.
- b) All work, in particular that which is not explicitly described in this work instruction, must be done in accordance with the referenced maintenance manual.
- c) In case of doubt, contact Diamond Aircraft Industries.

II DRAWINGS, SPECIAL TOOLS & MATERIALS

II.1 Drawings

None.

II.2 Special Tools

Ring saw Ø 25mm (1 in.)

II.3 Material:

Quantity	Description	Part No.
50g	Resin System	Acc. with AMM
4	Blanking Plug	245-032

Materials are available from Diamond Aircraft Industries.

III INSTRUCTIONS

1	Remove elevator in acc. with AMM Section 55-20.
2	Drill the 4 holes in acc. with sketch 1. <u>CAUTION:</u> Always observe safety precaution acc. to AMM Section 51-20.
4	Remove foam core (5-7 mm or 0.2 to 0.25 in.) at the edge of the holes in the elevator lower shell. <u>CAUTION:</u> Always observe safety precaution acc. to AMM Section 51-20.
5	Fill the gap with thickened resin in acc. with AMM. <u>CAUTION:</u> Always observe safety precaution acc. to AMM Section 51-20.
6	Precure the thickened resin in acc. with AMM Section 51-20.
7	Post-cure the elevator repair 12 hrs. at min. 60 °C (140 °F).
8	Install the blanking plugs in the elevator access holes and check for proper fit, in acc. with sketch 1 (Detail X).

9	Make an evaluation of the new weight and residual moment of the control surface in acc. with AMM (Section 51-60).
10	Install elevator in acc. with AMM Section 55-20.
11	Clean working area and check for foreign objects.
12	Perform functional check of altered, repaired and new parts.
13	Test all systems in working area for function.
14	Make necessary entries into aircraft logs.

Sketch 1

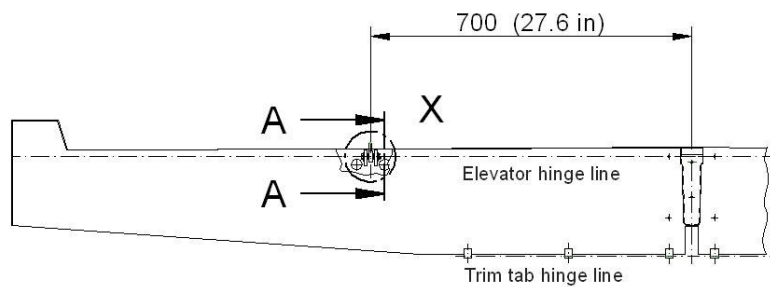

Section A-A

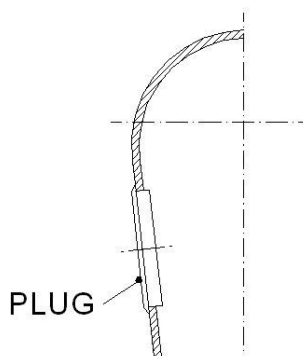

Detail X

