

MANDATORY SERVICE BULLETIN

NO. MSB-40-044/1

SUPERSEDES MSB-40-044

I TECHNICAL DETAILS

I.1 Category

Mandatory

I.2 Airplanes affected

Type: DA 40

Serial Numbers: 40.028, 40.029, 40.032 through 40.037, 40.041 through 40.045,
40.048, 40.049, 40.058, 40.059, 40.065, 40.068
40.201 through 40.305, 40.307 through 40.584

I.3 Time of Compliance

At next 100 hours inspection but not later than 30 June 2006.

I.4 Subject

Installation of muffler brace.

I.5 Reason

To prevent cracks in exhaust riser pipes.

I.6 Concurrent Documents

None.

I.7 Approval

The technical information or instructions contained in this document relate to the Design Change Advisory No. MÄM 40-225/a, which has been approved under the authority of EASA Design Organization Approval No. EASA.21J.052.

The technical content of this document has been approved und the authority of DOA No. EASA.21J.052.

I.8 Accomplishment/Instructions

- a. Comply with WI-MSB-40-044, latest effective issue.
- b. Incorporate AMM-TR-40-225 into the AMM

I.9 Mass (Weight) and CG

No appreciable change to weight and balance.

II PLANNING INFORMATION**II.1 Material & Availability**

WI-MSB-40-044 is attached to this MSB.
Needed parts and TR are available through DAI.

II.2 Special Tools

None.

II.3 Labor Effort

Approx. 3 manhours.

II.4 Credit

Parts and labor credit for aircraft under warranty and parts only credit for aircraft out of warranty. All work must be completed and a claim submitted not later than June 30, 2006 in order to be eligible for credit.

II.5 Reference Documents

WI-MSB-40-044, latest effective issue.
DA 40 Airplane Maintenance Manual Doc. No. 6.01.01-E
Temporary Revision AMM-TR-40-225

III REMARKS

- a) The work must be carried out by a certified aircraft service station or a certified aircraft maintenance mechanic. In case of doubt, contact Diamond Aircraft.
- b) All works, particular those that are not especially described in this work instruction, have to be carried out in accordance with the referenced maintenance manual.

WORK INSTRUCTION

WI-MSB-40-044

„INSTALLATION OF EXHAUST BRACE“

I GENERAL INFORMATION

I.1 Subject:

The installation of exhaust brace on DA 40.

I.2 Reference Documents:

Diamond Aircraft DA 40 Airplane Maintenance Manual, Doc. No. 6.02.01, latest effective issue.

I.3 Remarks:

- a) The work must be carried out by a certified aircraft service station or a certified aircraft maintenance mechanic. In case of doubt, contact Diamond Aircraft.
- b) All work, particular those that are not especially described in this work instruction, have to be carried out in accordance with the referenced maintenance manual.

II DRAWINGS, SPECIAL TOOLS & MATERIALS

II.1 Drawings:

D41-7806-00-00_1 Muffler Brace Installation.

II.2 Special Tools:

None.

II.3 Material:

Qty	Description	Part Number
1	Muffler brace	D41-7806-20-01
1	Muffler brace support bracket	D41-7806-20-02
2	Muffler shroud doubler	D41-7806-20-03
2	Muffler shroud spacer	D41-7806-20-04
4	Rivet, blind	CCCQ-04-04
2	Bolts	AN3C5A

8	Washers	AN960C10L
2	Self-locking nuts	MS21042-3
2	Spring washer	MS35338-44
4	Gasket	77611
8	Self-locking nuts	STD-2233
2	Bolts	AN4-5A
4	Washers	AN960-416
2	Self-locking nuts.	MS21042-4

III INSTRUCTIONS

1	Remove the engine cowlings (refer to AMM Section 71-10).
2	Remove the exhaust muffler from the engine by removing the nuts that fasten the risers to the cylinders (refer to AMM Section 78-00). Discard all used gaskets and star washers.
3	Remove the muffler shroud (refer to AMM Section 78-00).
4	Perform a thorough visual inspection of the exhaust system.
5	Align muffler shroud doubler with outer holes on aft flange of shroud and drill two rivet holes Ø0.125" (3.2mm) at each end of flange.
6	Install muffler shroud doubler and muffler shroud spacer with CCCQ-04-04 rivets as shown in drawing D41-7806-00-00_1.
7	Install muffler shroud (refer to AMM Section 78-00) leaving out outer screws and Tinnerman nuts.
8	Install muffler brace (P/N D41-7806-20-01) onto the upper/forward face of the muffler shroud flange using two AN3C5A bolts, six AN960C10L washers (one under the head of each bolt, one under each nut, and one between the shroud flanges at each location) and two MS21042-3 self-locking nuts.
9	Remove the 2 bolts and washers that fasten the throttle cable bracket to the throttle cable boss. Discard the spring washers but retain the bolts and plain washers.
10	Install the muffler brace support bracket (P/N D41-7806-20-02) to the throttle cable boss using the bolts and plain washers removed in the previous step and new spring washers MS35338-44. Do not fully tighten the bolts. The brace support bracket should be able to move freely. The throttle cable bracket should be in between the brace support bracket and the throttle cable boss.
11	Raise the system up to the cylinders and using new gaskets installed per Lycoming Service Instruction No. 1204B, with plain washers and STD-2233 nuts draw the risers up to the cylinders so they are snug. Tighten nuts sequentially working from one side of the engine to the other in a crossing pattern. Torque to 17 foot pounds (23 Nm) in a minimum of two steps, working sequentially from one side of the engine to the other in a crossing pattern. NOTE: Add friction torque to this value to get final torque.

12	Adjust the support bracket to the position where it is best aligned with the brace. It may be necessary to loosen and rotate the muffler shroud to obtain the best fit between the brace and support bracket. If necessary to prevent the brace from bending, install an additional AN960C10L washer between the brace and the muffler shroud flange.
13	Fasten the brace and support bracket using two AN4-5A bolts, four AN960-416 washers and two MS21042-4 self-locking nuts.
14	Tighten the two throttle cable boss bolts and secure with safety wire.
15	Install cowlings (Refer to AMM Section 71-10).

NOTE: Torque exhaust riser nuts after first flight.



Diamond Aircraft Industries GmbH
N. A. Otto-Straße 5
A-2700 Wiener Neustadt

WI-MSB-40-044
Revision 1
Appendix
11-Jan-2005

IV APPENDIX

IV.1 Drawing:

- D41-7806-00-00_1 Rev. "e"

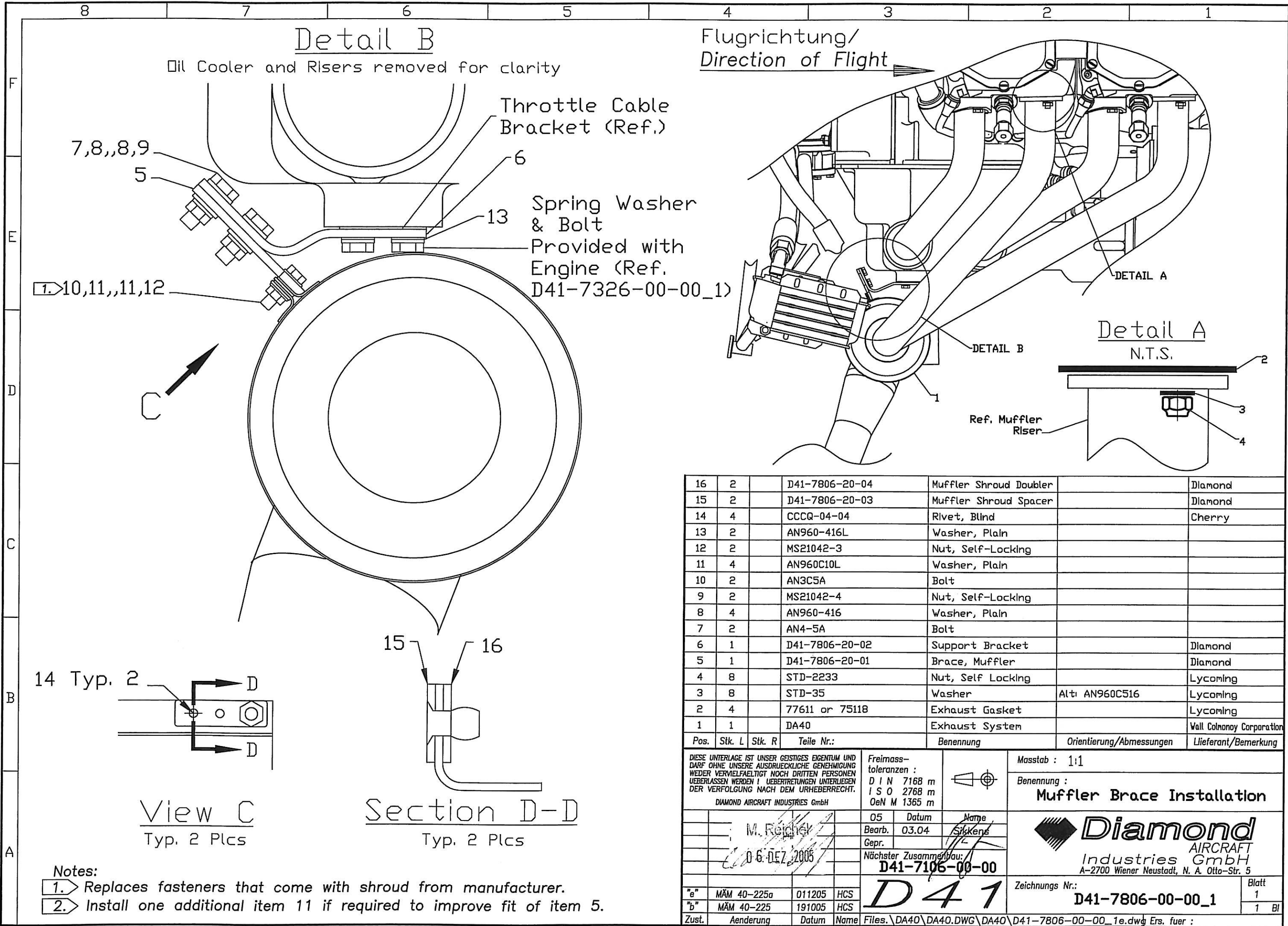

Pos.	Stk. L	Stk. R	Teile Nr.:	Benennung	Orientierung/Abmessungen	Lieferant/Bemerkung
16	2		D41-7806-20-04	Muffler Shroud Doubler		Diamond
15	2		D41-7806-20-03	Muffler Shroud Spacer		Diamond
14	4		CCCQ-04-04	Rivet, Blind		Cherry
13	2		AN960-416L	Washer, Plain		
12	2		MS21042-3	Nut, Self-Locking		
11	4		AN960C10L	Washer, Plain		
10	2		AN3C5A	Bolt		
9	2		MS21042-4	Nut, Self-Locking		
8	4		AN960-416	Washer, Plain		
7	2		AN4-5A	Bolt		
6	1		D41-7806-20-02	Support Bracket		Diamond
5	1		D41-7806-20-01	Brace, Muffler		Diamond
4	8		STD-2233	Nut, Self Locking		Lycoming
3	8		STD-35	Washer	Alt: AN960C516	Lycoming
2	4		77611 or 75118	Exhaust Gasket		Lycoming
1	1		DA40	Exhaust System		Wall Colmanoy Corporation

DIESE UNTERLAGE IST UNSER GEISTIGES EIGENTUM UND DARF OHNE UNSERE AUSDRUECKLICHE GENEHMIGUNG WEDER VERVIELFACHTET NOCH DRITTEN PERSONEN UEBERLASSEN WERDEN! UEBERTRETUNGEN UNTERLIEGEN DER VERFOLGUNG NACH DEM URHEBERRECHT.
 DIAMOND AIRCRAFT INDUSTRIES GmbH

Freimass-toleranzen:
 DIN 7168 m
 ISO 2768 m
 OeN M 1365 m

Masstab: 1:1
 Benennung: **Muffler Brace Installation**

Diamond
 AIRCRAFT
 Industries GmbH
 A-2700 Wiener Neustadt, N. A. Otto-Str. 5

Zeichnungs Nr.: **D41-7806-00-00_1** Blatt 1/1 Bl

05 Datum Name
 Bearb. 03.04. Sikkens
 Gepr.

Nächster Zusammenbau:
D41-7106-00-00

D41

Zust. Änderung Datum Name Files: \DA40\DA40.DWG\DA40\DA1-7806-00-00_1e.dwg Ers. fuer:

- Notes:
- 1. Replaces fasteners that come with shroud from manufacturer.
 - 2. Install one additional item 11 if required to improve fit of item 5.