

RECOMMENDED SERVICE BULLETIN NO. RSB40-011/1

SUPERSEDES SERVICE BULLETIN NO. RSB40-011

I. TECHNICAL DETAILS

1.1 Category

Recommended.

1.2 Airplanes affected

DA 40 all serial numbers up to and incl. 40.082 and from 40.201 up to and incl. 40.224.

1.3 Time of Compliance

At owners' discretion.

1.4 Subject

Starter relay.

ATA-Code: 80-00

1.5 Reason

The installation of an improved starter relay due to the possible welding of starter relay contacts.

1.6 Concurrent documents

Work Instruction WI-RSB40-011, latest effective issue.

1.7 Approval

The information and instructions contained in this document relate to the Design Change Advisories MÄM40-057 and OÄM40-116 which have been approved under the authority of JAA Design Organization Approval No. MOT JA-01.

The technical information contained in this document has been approved under the authority of JAA Design Organization Approval No. MOT JA-01.

1.8 Accomplishment/Instructions

The Work Instruction WI-RSB40-011, latest effective issue has to be complied with in order to install the improved relay box.

1.9 Recurring Actions

None.

1.10 Mass (Weight) and CG

Not affected.

II. PLANNING INFORMATION

2.1 Material & Availability

All parts can be obtained from Diamond Aircraft Industries GmbH or from your local General Distributor or Diamond Service Center.

2.2 Special Tools

No special tools are required.

2.3 Labour

6 hours for all serial numbers up to and incl. 40.049.

3 hours for serial numbers from 40.050 up to and incl. 40.082 and from 40.201 up to and incl. 40.224.

2.4 Reference documents

Diamond DA40 Airplane Maintenance Manual, Doc. No. 6.02.01.

2.5 Credit

None.

III. REMARKS

Unless otherwise prescribed, the work must be carried out in accordance with the instructions of the Airplane Maintenance Manual, Doc. No. 6.02.01. The work must be carried out by a certified aircraft service station or a certified aircraft maintenance mechanic.

WORK INSTRUCTION

WI-RSB40-011/1

„STARTER RELAY INSTALLATION“

SUPERSEDES WORK INSTRUCTION NO. WI-RSB40-011

SUBJECT

The installation of the improved starter relay.

DRAWINGS, MATERIALS, SPECIAL TOOLS

FOR ALL SERIAL NUMBERS

UP TO AND INCL. 40.049

NOTE: If part numbers in parenthesis are available, they must be used when ordering.

Materials

<u>Qty</u>	<u>Description</u>	<u>Part Number</u>
1	Relay Panel	17.6020 (DA4-2466-11-00)
1	Fuse Holder	17.6010 (DA4-2466-10-02)
1	Hot Battery Bus	17.6016 (DA4-2466-11-03)
0.1 m	Heat Shrink	17.0851
0.2 m	Heat Shrink	17.0854
2	Lock Nut	MS21044N3
2	C.S. Bolt	MS24693-S274
2	Washer	11.5210 (AN960-10)

1	Spacer	17.6015 (DA4-2466-10-06)
1	Kissling Relay	17.6002 (26-58-09)
1	Bus Bar	17.6017 (DA4-2466-10-05)
2	Bolt	11.5300 (AN3-6A)
1	Starter Cable	17.6011
1	Ring Terminal	17.6018 (36154)
2	Ring Terminal	17.6019 (31886)
0.1m(=4in)	Cable AWG 22	17.1590
1	Relay Box Cover	40.1530
1	Ring Terminal	17.6022 (31897)

Drawings

- DA4-2466-10-00"b"
- DA4-2466-10-00"d"
- DA4-2406-30-00"a"

Special Tools

None.

ACCOMPLISHMENT INSTRUCTIONS

WARNING

WORK MUST BE DONE IN THE ENGINE COMPARTMENT. MAKE SURE THAT THE ENGINE IS SAFE BEFORE YOU WORK ON IT.

MAKE SURE THAT THE IGNITION SWITCH IS SET TO "OFF". SET THE THROTTLE TO "IDLE" AND THE MIXTURE TO "LEAN".

1	Remove upper cowling
2	Disconnect battery (negative pole first)
3	Release relay box cover
4	Disconnect cables
5	Remove starter cable (no. 80104 A4)
6	Remove the complete relay panel (item 1, dwg. no. DA4-2466-10-00"b")
7	Remove bus bar and hot battery bus (items 2 and 4, dwg. no. DA4-2466-10-00"b")
8	Release all three relays
9	Release fuse holders (items 20, dwg. no. DA4-2466-10-00"b") from the fuse holder bracket (item 3, dwg. no. DA4-2466-10-00"b")
10	Remove fuse holder bracket (item 3, dwg. no. DA4-2466-10-00"b")
11	Install new starter cable part # 17.6011 in accordance with the Airplane Maintenance Manual Doc No. 6.02.01
12	Install spacer part # 17.6015 with C.S. Bolts part # MS24693-S274, Lock Nut part # MS21044N3 and washer part # 11.5210 on Kissling relay part # 17.6002 (items 5, 7, 9, 12, 24, dwg. no. DA4-2466-10-00"d")
13	Install EPU relay (S-1577A1) and battery relay (S-1580A1) (items 22 and 21, dwg. no. DA4-2466-10-00"d") on new relay panel part # 17.6020
14	Build ground cable from ring terminals 17.6018, 17.6019 and wire 17.1590 in accordance with dwg. no. DA4-2406-30-00"a" (items 36, 11, 78)
15	Install new ring terminals part # 17.6022 (item 37, dwg. no. DA4-2406-30-00"a") on wire # 80103A22 and part # 17.6019 (item 78, dwg. no. DA4-2406-30-00"a") on wire # 80101B22/74104A22/ Diode)
16	Install ground cable on the starter relay connection 85 in accordance with dwg. no. DA4-2406-30-00"a"

17	Install Kissling starter relay part # 17.6002 (item 24, dwg. no. DA4-2466-10-00"d") on new relay panel part # 17.6020 with bolts part # 11.5300 (item 8, dwg. no. DA4-2466-10-00"d") and washers and connect the ground cable in accordance with dwg. no. DA4-2406-30-00a
18	Install bus bar part # 17.6017 with heat shrinks part # 17.0854 (items 2 and 14, dwg. no. DA4-2466-10-00"d")
19	Install fuse holder bracket part # 17.6010 (item 3, dwg. no. DA4-2466-10-00"d")
20	Install fuses and fuse holders (items 20 and 23, dwg. no. DA4-2466-10-00"d")
21	Install hot battery bus part # 17.6016 and heat shrink part # 17.0851 (items 4 and 13, dwg. no. DA4-2466-10-00"d"). Solder bus to fuse tab
22	Install assembled relay panel
23	Connect cables
24	Check for foreign objects
25	Ensure a tight fit of all parts
26	Install the new relay box cover part # 40.1530
27	Connect battery
28	Install upper cowling

DRAWINGS, MATERIALS, SPECIAL TOOLS

FOR SERIAL NUMBERS

FROM 40.050 UP TO AND INCL. 40.082

AND

FROM 40.201 UP TO AND INCL. 40.224

NOTE: If part numbers in parenthesis are available, they must be used when ordering.

Materials

<u>Qty</u>	<u>Description</u>	<u>Part Number</u>
1	Kissling Relay	17.6002 (26-58-09)
1	Spacer	17.6015 (DA4-2466-10-06)
1	Bus Bar	17.6017 (DA4-2466-10-05)
2	Bolt	11.5300 (AN3-6A)
2	Washer	11.5210 (AN960-10)
1	Starter Cable	17.6011
2	Lock Nut	MS21044N3
2	C.S. Bolt	MS24693-S274
0.2 m	Heat Shrink	17.0854
1	Ring Terminal	17.6018 (36154)
2	Ring Terminal	17.6019 (31886)
0.1m(=4in)	Cable AWG 22	17.1590
1	Relay Box Cover	40.1530
1	Ring Terminal	17.6022 (31897)

Drawings

- DA4-2466-10-00"c"
- DA4-2466-10-00"d"
- DA4-2406-30-00"a"

Special Tools

None

ACCOMPLISHMENT INSTRUCTIONS**WARNING**

WORK MUST BE DONE IN THE ENGINE COMPARTMENT. MAKE SURE THAT THE ENGINE IS SAFE BEFORE YOU WORK ON IT.

MAKE SURE THAT THE IGNITION SWITCH IS SET TO "OFF". SET THE THROTTLE TO "IDLE" AND THE MIXTURE TO "LEAN".

1	Remove upper cowling
2	Disconnect battery (negative pole first)
3	Release relay box cover
4	Disconnect cables
5	Remove starter cable
6	Remove bus bar (item 2, dwg. no. DA4-2466-10-00"c")
7	Release starter (middle) relay
8	Install new starter cable part # 17.6011 in accordance with the Airplane Maintenance Manual Doc No. 6.02.01
9	Install spacer part # 17.6015 with C.S. Bolts part # MS24693-S274, Lock Nut part # MS21044N3 and washer part # 11.5210 on Kissling relay part # 17.6002 (items 5, 7, 9, 12, 24, dwg. no. DA4-2466-10-00"d")
10	Build ground cable from ring terminals 17.6018, 17.6019 and wire 17.1590 in accordance with dwg. no. DA4-2406-30-00"a" (items 36, 11, 78)

11	Install new ring terminals part # 17.6022 (item 37, dwg. no. DA4-2406-30-00"a") on wire # 80103A22 and part # 17.6019 (item 78, dwg. no. DA4-2406-30-00"a") on wire # 80101B22/74104A22/ Diode)
12	Install ground cable on the starter relay connection 85 in accordance with dwg. no. DA4-2406-30-00"a"
13	Install Kissling starter relay part # 17.6002 (item 24, dwg. no. DA4-2466-10-00"d") on relay panel with bolts part # 11.5300 (item 8, dwg. no. DA4-2466-10-00"d") and washers and connect the ground cable in accordance with dwg. no. DA4-2406-30-00a
14	Install bus bar part # 17.6017 with heat shrinks part # 17.0854 (items 2 and 14, dwg. no. DA4-2466-10-00"d")
15	Connect cables
16	Check for foreign objects
17	Ensure a tight fit of all parts
18	Install the new relay box cover part # 40.1530
19	Connect battery
20	Install upper cowling

REFERENCE DOCUMENTS

Diamond Aircraft DA 40 Airplane Maintenance Manual, Doc.No.6.02.01

REMARK

Unless otherwise prescribed, the work must be carried out in accordance with the instructions of the Airplane Maintenance Manual, Doc. No. 6.02.01. The work must be carried out by a certified aircraft service station or a certified aircraft maintenance mechanic.

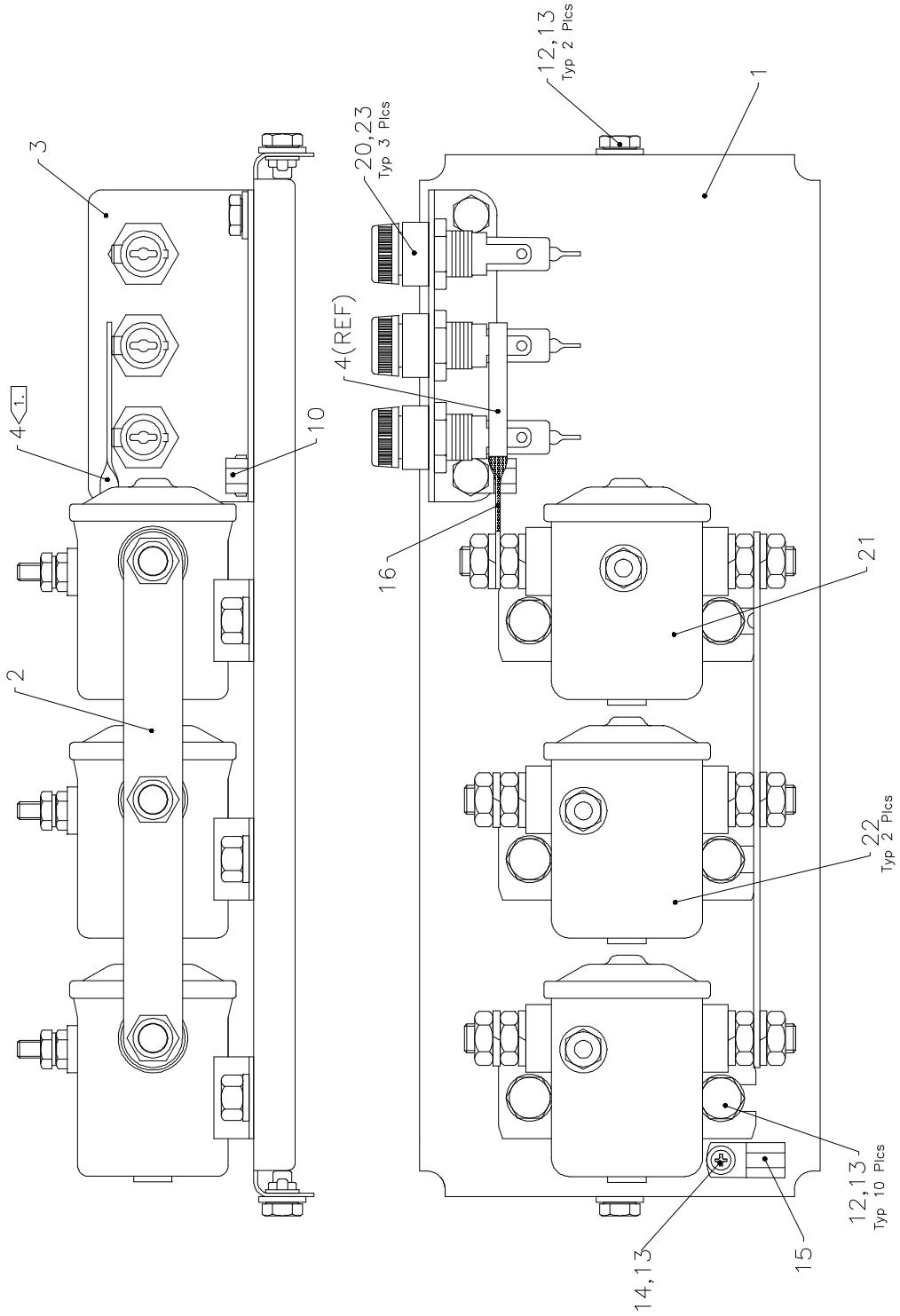

DA4-2466-10-00"b"

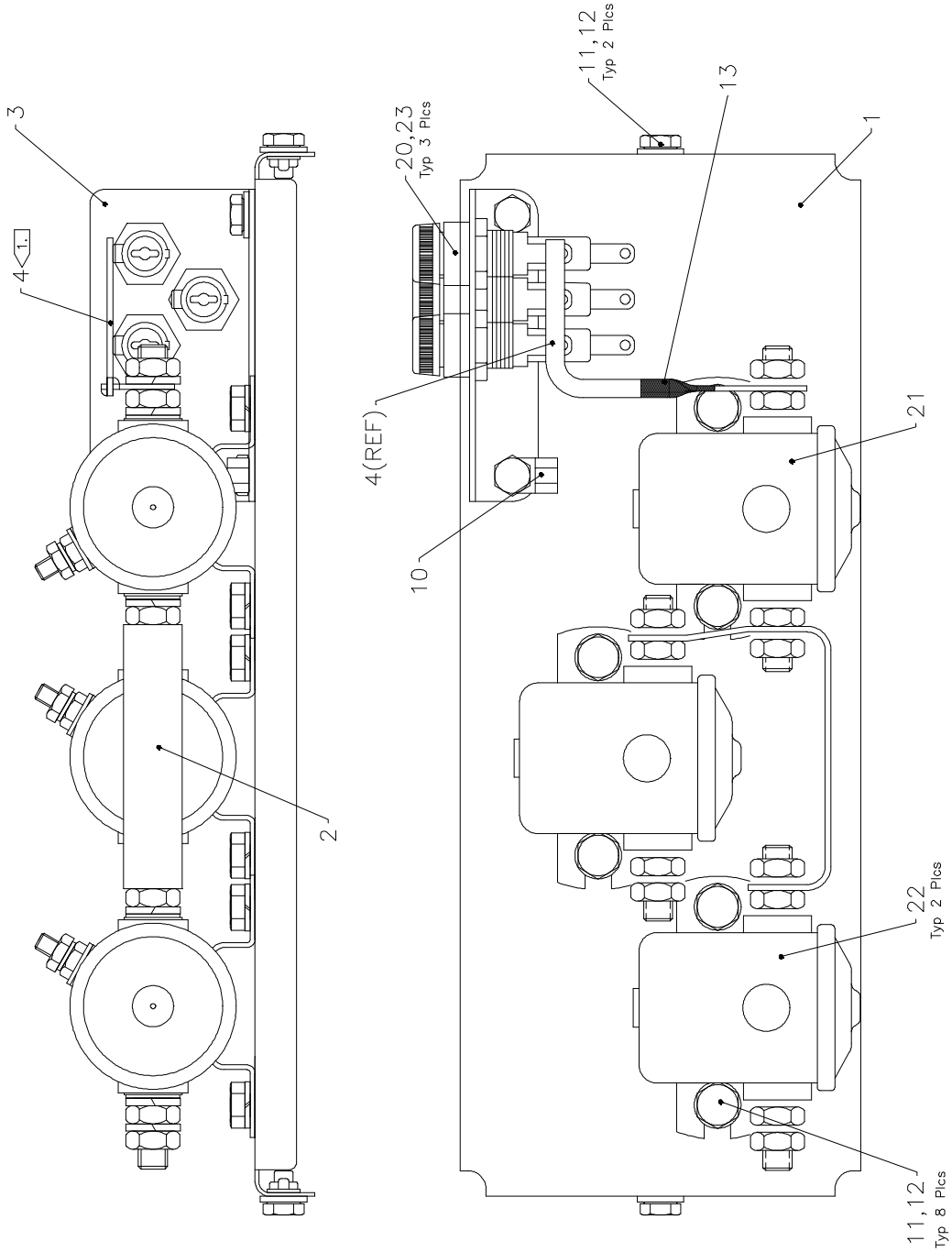

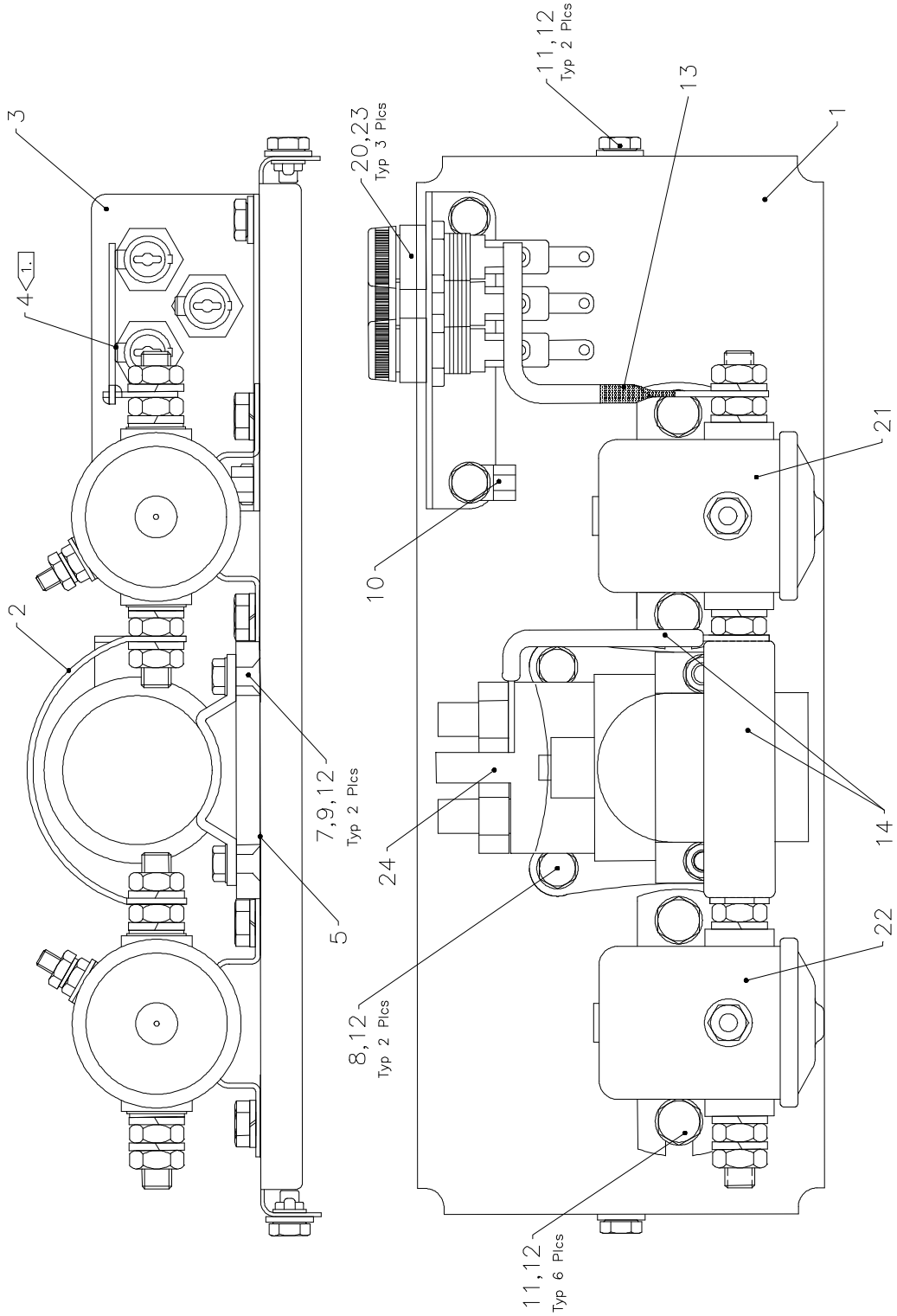

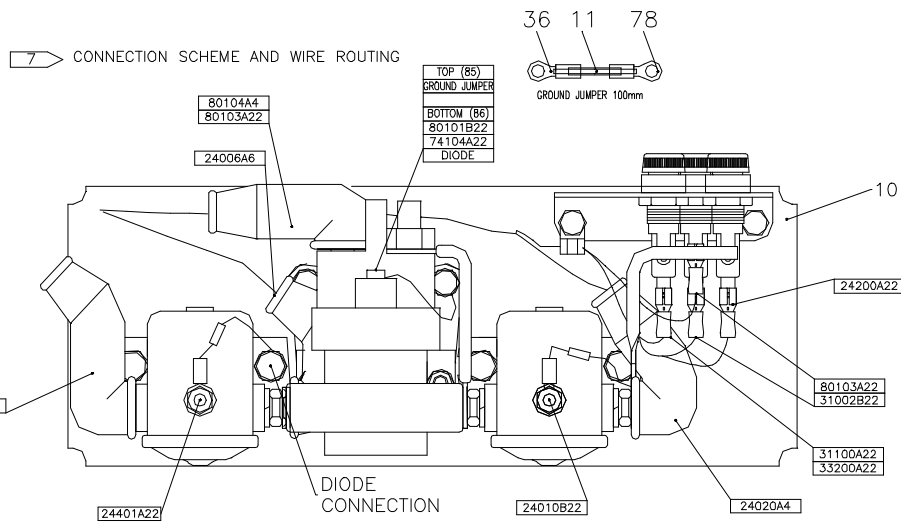
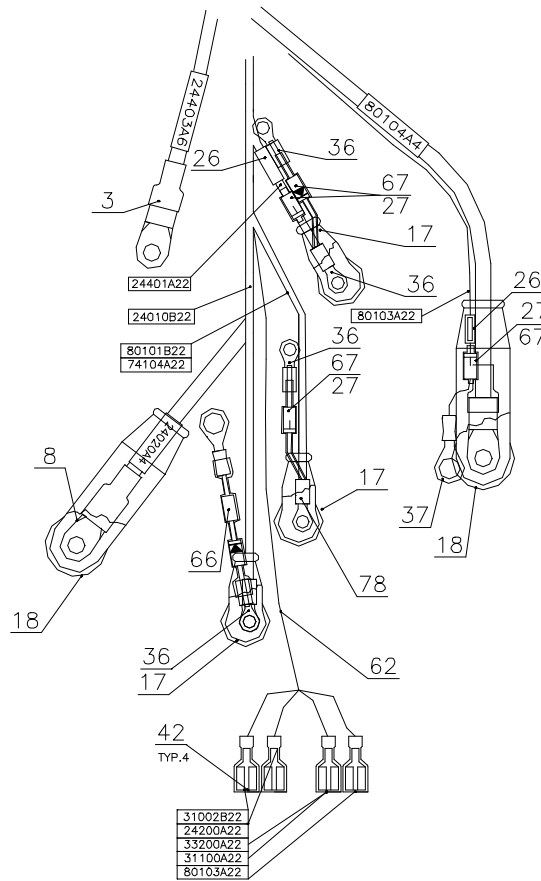

DA4-2406-30-00"a"