



SUPPLEMENT S2
TO THE AIRPLANE FLIGHT MANUAL DA 40
EMERGENCY LOCATOR TRANSMITTER
JE2-NG
JOLLIET ELECTRONIQUE

Doc. No. : 6.01.01-E
Date of Issue of the Supplement : 01 June 2001
Design Change Advisory : OÄM 40-090

Signature : 
 Authority : AUSTRO CONTROL
 Stamp : 
 Date of approval : 09. SEP. 2001

This Supplement has been approved for the Joint Aviation Authorities (JAA) by the Austrian Civil Aviation Authority Austro Control (ACG) as Primary Certification Authority (PCA) in accordance with the JAA Certification Procedures of the Joint Aviation Authorities (JAA JC/VP).

DIAMOND AIRCRAFT INDUSTRIES GMBH
N.A. OTTO-STR. 5
A-2700 WIENER NEUSTADT
AUSTRIA

0.1 RECORD OF REVISIONS

Rev. No.	Chapter	Pages	Date of Revision	Date Inserted	Signature

0.2 LIST OF EFFECTIVE PAGES

Chapter	Page	Date
0	9-S2-1	01 Jun 2001
	9-S2-2	01 Jun 2001
	9-S2-3	01 Jun 2001
1, 2	9-S2-4	01 Jun 2001
3	9-S2-4	01 Jun 2001
	9-S2-5	01 Jun 2001
4A, 4B	9-S2-5	01 Jun 2001
5, 6	9-S2-6	01 Jun 2001
7	9-S2-6	01 Jun 2001
	9-S2-7	01 Jun 2001
	9-S2-8	01 Jun 2001
	9-S2-9	01 Jun 2001
	9-S2-10	01 Jun 2001
8	9-S2-10	01 Jun 2001

0.3 TABLE OF CONTENTS

	Page
1. GENERAL	9-S2-4
2. OPERATING LIMITATIONS	9-S2-4
3. EMERGENCY PROCEDURES	9-S2-4
4A. NORMAL OPERATING PROCEDURES	9-S2-5
4B. ABNORMAL OPERATING PROCEDURES	9-S2-5
5. PERFORMANCE	9-S2-6
6. MASS AND BALANCE	9-S2-6
7. DESCRIPTION OF THE AIRPLANE AND ITS SYSTEMS	9-S2-6
8. AIRPLANE HANDLING, CARE AND MAINTENANCE	9-S2-10

1. GENERAL

This Supplement supplies the information necessary for the efficient operation of the airplane when the Joliet JE2-NG ELT is installed. The information contained within this Supplement is to be used in conjunction with the complete AFM.

This Supplement is a permanent part of this AFM and must remain in this AFM at all times when the Joliet JE2-NG ELT is installed.

2. LIMITATIONS

No change.

3. EMERGENCY PROCEDURES

Before performing a forced landing, especially in remote and mountainous areas, activate the ELT transmitter by positioning the remote switch to the MANU position.

Immediately after a forced landing where emergency assistance is required, the ELT should be utilized as follows:

NOTE

The ELT remote switch system could be inoperative if damaged during a forced landing. If inoperative, the inertia 'G' switch will activate automatically. However, to turn the ELT OFF and ON again requires manual switching of the master function selector switch which is located on the ELT unit.

1. ENSURE ELT ACTIVATION:
 - Position remote switch to the MANU position.
 - If the airplane's radio is operable and can be safely used (no threat of fire or explosion), turn ON and select 121,5 MHz. If the ELT can be heard transmitting, it is working properly.
2. PRIOR TO SIGHTING RESCUE AIRCRAFT:
 - Conserve airplane battery. Do not activate radio transceiver.
3. AFTER SIGHTING RESCUE AIRCRAFT:
 - Position the MANU-OFF/RST-AUTO switch on the ELT unit to OFF/RST position. Attempt contact with rescue aircraft with the radio transceiver set to a frequency to 121,5 MHz. If no contact is established, return the MANU-OFF/RST-AUTO switch to MANU position immediately.
4. FOLLOWING RESCUE
 - Position MANU-OFF/RST-AUTO to the OFF/RST position, terminating emergency transmissions.

4A. NORMAL OPERATING PROCEDURES

No change.

4B. ABNORMAL OPERATING PROCEDURES

No change.

5. PERFORMANCE

No change.

6. MASS AND BALANCE

Upon removal or installation of the Jolliet JE2-NG ELT the change of empty mass and corresponding center of gravity of the airplane must be recorded according to Chapter 6 of the Airplane Flight Manual.

7. DESCRIPTION OF THE AIRPLANE AND ITS SYSTEMS

7.14 AVIONICS

GENERAL

The Jolliet JE2-NG ELT is an automatically activated Emergency Locator Transmitter. It may also be manually activated via the MANU-OFF/RST-AUTO switch on the unit, or via the remote AUTO/MANU switch on the instrument panel of the DA 40.

When the JE2-NG is switched on, the ELT broadcasts simultaneously on the international distress frequencies 121,5 MHz and 243, 0 MHz a 'typical' modulated signal.

DESCRIPTION

The Jolliet JE2-NG ELT is an orange plastic box, fixed on a mounting tray and locked by a metallic strap with a 'quick-opening' latch.

The various controls, switches and connections are located on the front panel.

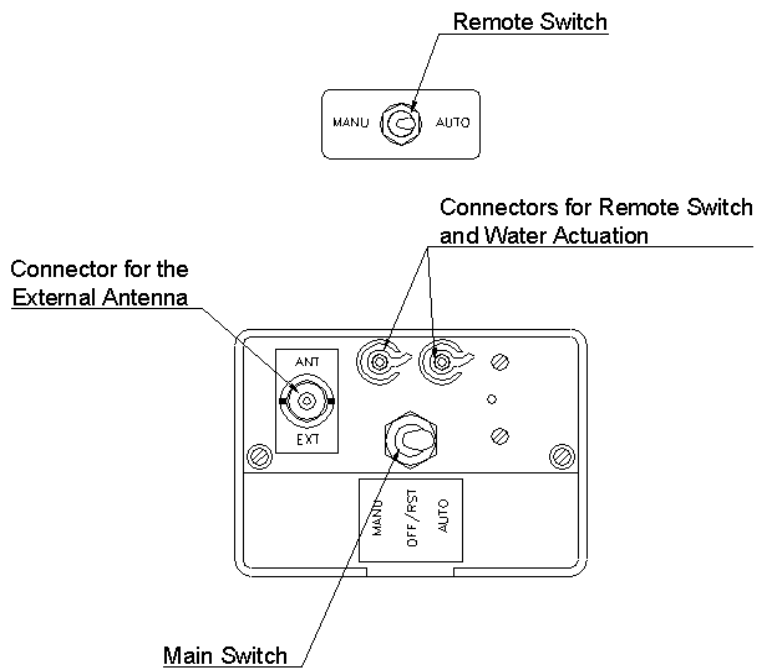

The portable antenna is a metallic and flexible blade, rolled round the ELT case, inside a specific groove. For use, the antenna must be fully extended by pulling the 'T' tab.

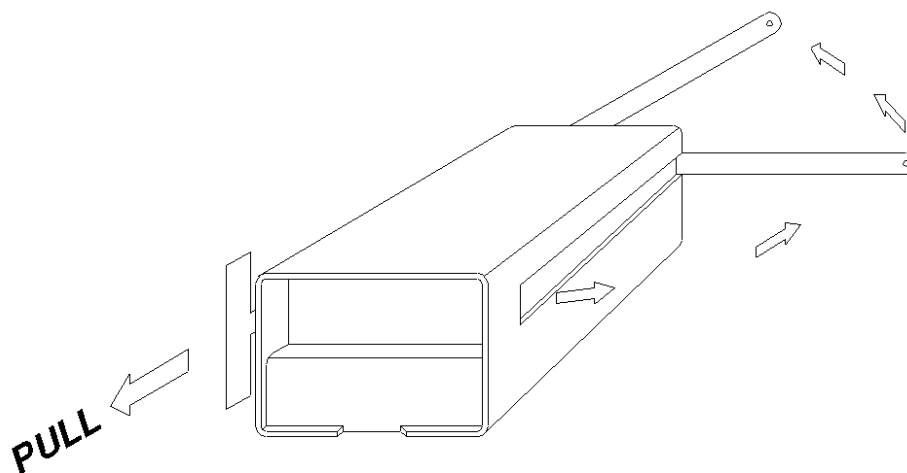

AUTOMATIC OPERATION

The Joliet JE2-NG Emergency Locator Transmitter is equipped with an impact 'G' switch, that will automatically activate the transmitter when a 'G' force is applied to the longitudinal axis of the ELT, from nose to back. In this case, no manual intervention is necessary, but the ELT must have been prepared before the flight as follow:

- check that the BNC connector of the antenna cable is secure on the connector of control head, and that contact finger separator is insert between the antenna contact finger and the portable antenna.
- Position the MANU-OFF/RST-AUTO switch on the ELT unit to AUTO

MANUAL OPERATION

In this type of operation, the ELT must be removed from its mounting tray and held with the hand or vertically placed on a clear spot, its portable antenna pointing skyward.

- If no external wires are connected to the ELT, simply open the latch on the strap and slide forward and up the JE2-NG out of its bracket.
- If the ELT has wires attached to it, proceed as follow:
 - Remove antenna cable by pushing and turning counterclockwise its connector and then pull it up. This action will also put out the contact finger separator.
 - A tool (a Ø 5,5 mm socket wrench) is necessary to remove the two others wires (for remote switch). If this tool is unavailable, break or cut this two wires.
 - Extend the portable antenna by pulling out the 'T' shaped tab which is fixed on its end.
 - Position the MANU-OFF/RST-AUTO switch to MANU (manual).

The JE2-NG ELT is working; but as for all other radio transmitters you cannot hear the signal, except if your airplane VHF is yet functioning and had been tuned to 121,5 MHz.

REMOTE MANUAL OPERATION

When an emergency landing is imminent, and when all other emergency procedures have been completed, the JE2-NG ELT may be manually activated by the pilot before the emergency landing. (see also Emergency Procedures)

The remote switch has a guard. For positioning it to MANU, the switch has to be pulled out and simultaneously moved to MANU. The ELT is working.

WATER ACTUATION CAPABILITY

When the JE2-NG ELT has been prepared for automatic operation, it may be actuated by water.

Effectively if the JE2-NG ELT is immersed, the conductivity of water will close the circuit between the two terminals on the top of the case and activate the ELT, as a remote switch should do.

Moreover, the hollow shaped upper side of the case will retain water and keep the JE2-NG working.

NOTE

For transmission of the distress signal the antenna must raise out of water.

8. AIRPLANE HANDLING, CARE AND MAINTENANCE

No change.