

**SUPPLEMENT A9
TO THE AIRPLANE FLIGHT MANUAL DA 40 (D)**

**AUTOMATIC DIRECTION FINDER
KR 87
BENDIX/KING**

Doc. No. : 6.01.01-E (DA 40)
6.01.05-E (DA 40 D)
Date of Issue of the Supplement : 01 Mar 2001
Design Change Advisory : OÄM 40-067 (DA 40)
OÄM 40-136 (DA 40 D)

Signature :

Authority :

Stamp :

Date of approval :

AUSTRO CONTROL GmbH
Abteilung Flugtechnik
Zentrale
A-1030 Wien, Schnirchgasse 11
18. JUNI 2003

This Supplement has been approved for the Joint Aviation Authorities (JAA) by the Austrian Civil Aviation Authority Austro Control (ACG) as Primary Certification Authority (PCA) in accordance with the JAA Certification Procedures of the Joint Aviation Authorities (JAA JC/VP).

**DIAMOND AIRCRAFT INDUSTRIES GMBH
N.A. OTTO-STR. 5
A-2700 WIENER NEUSTADT
AUSTRIA**

0.1 RECORD OF REVISIONS

Rev. No.	Chapter	Pages	Date of Revision	Date Inserted	Signature
1	all	all	20 Apr 2001		
2	all	all	17 Feb 2003		

0.2 LIST OF EFFECTIVE PAGES

Chapter	Page	Date
0	9-A9-1	17 Feb 2003
	9-A9-2	17 Feb 2003
	9-A9-3	17 Feb 2003
1, 2, 3, 4A, 4B, 5	9-A9-4	17 Feb 2003
6	9-A9-5	17 Feb 2003
7	9-A9-5	17 Feb 2003
	9-A9-6	17 Feb 2003
	9-A9-7	17 Feb 2003
	9-A9-8	17 Feb 2003
	9-A9-9	17 Feb 2003
	9-A9-10	17 Feb 2003
	9-A9-11	17 Feb 2003
	9-A9-12	17 Feb 2003
9-A9-13	17 Feb 2003	
8	9-A9-13	17 Feb 2003

0.3 TABLE OF CONTENTS

	Page
1. GENERAL	9-A9-4
2. OPERATING LIMITATIONS	9-A9-4
3. EMERGENCY PROCEDURES	9-A9-4
4A. NORMAL OPERATING PROCEDURES	9-A9-4
4B. ABNORMAL OPERATING PROCEDURES	9-A9-4
5. PERFORMANCE	9-A9-4
6. MASS AND BALANCE	9-A9-5
7. DESCRIPTION OF THE AIRPLANE AND ITS SYSTEMS	9-A9-5
8. AIRPLANE HANDLING, CARE AND MAINTENANCE	9-A9-13

1. GENERAL

This Supplement supplies the information necessary for the efficient operation of the airplane when the ADF KR 87 is installed. The information contained within this Supplement is to be used in conjunction with the complete AFM.

This Supplement is a permanent part of this AFM and must remain in this AFM at all times when the ADF KR 87 is installed.

2. LIMITATIONS

No change.

3. EMERGENCY PROCEDURES

No change.

4A. NORMAL OPERATING PROCEDURES

No change.

4B. ABNORMAL OPERATING PROCEDURES

No change.

5. PERFORMANCE

No change.

6. MASS AND BALANCE

Upon removal or installation of the ADF System KR 87 the change of empty mass and corresponding center of gravity of the airplane must be recorded according to Chapter 6 of the Airplane Flight Manual.

7. DESCRIPTION OF THE AIRPLANE AND ITS SYSTEMS

7.14 AVIONICS

The Bendix/King Digital ADF is a panel-mounted, digitally tuned automatic direction finder. It is designed to provide continuous 1 kHz digital tuning in the frequency range of 200 kHz to 1799 kHz and eliminates the need for mechanical band switching. The system is comprised of a receiver, a built-in electronics timer, a bearing indicator, and a KA 44B combined loop and sense antenna. Operating controls and displays for the Bendix/King Digital ADF are shown and described are shown in the Figure below.

The Bendix/King Digital ADF can be used for position plotting and homing procedures, and for aural reception of amplitude-modulated (AM) signals.

The 'flip-flop' frequency display allows switching between preselected 'STANDBY' and 'ACTIVE' frequencies by pressing the frequency transfer button. Both pre-selected frequencies are stored in a non-volatile memory circuit (no battery power required) and displayed in large, easy-to-read, self-dimming gas discharge numerics. The active frequency is continuously displayed in the left window, while the right window will display either the standby frequency or the selected readout from the built-in electronic timer.

The built-in electronic timer has two separate and independent timing functions.

- An automatic flight timer that starts whenever the unit is turned on. This timer functions up to 59 hours and 59 minutes.

- An elapsed timer which will count up or down for up to 59 minutes and 59 seconds.

When a preset time interval has been programmed and the countdown reaches :00, the display will flash for 15 seconds. Since both the flight timer and elapsed timer operate independently, it is possible to monitor either one without disrupting the other. The pushbutton controls and the bearing indicators are internally lighted. Intensity is controlled by the instrument lights potentiometer.

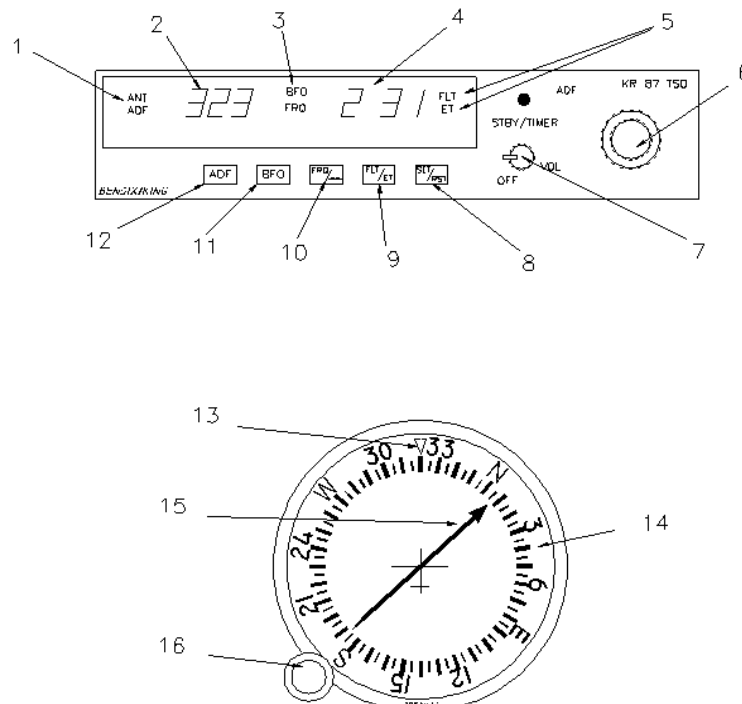

1. ANT/ADF MODE ANNUNCIATOR - Antenna (ANT) is selected by the 'out' position of the ADF button. This mode improves the audio reception and is usually used for station identification.

The bearing pointer is deactivated and will park in the 90° relative position. Automatic Direction Finder (ADF) mode is selected by the depressed position of the ADF button. This mode activates the bearing pointer. The bearing pointer will point in the direction of the station relative to the airplane heading.

2. IN-USE FREQUENCY DISPLAY - The frequency to which the ADF is tuned is displayed here. The active ADF frequency can be changed directly when either of the timer functions is selected.
3. BFO (Beat Frequency Oscillator) ANNUNCIATOR - The BFO mode, activated and annunciated when the 'BFO' button is depressed, permits the carrier wave and associated morse code identifier broadcast on the carrier wave to be heard.

NOTE

CW signals (Morse Code) are unmodulated and no audio will be heard without use of BFO. This type of signal is not used in the United States air navigation. It is used in some other countries and marine beacon.

4. STANDBY FREQUENCY/FLIGHT TIME OR ELAPSED TIME ANNUNCIATION - When FRQ is displayed the STANDBY frequency is displayed in the right hand display. The STANDBY frequency is selected using the frequency select knobs. The selected STANDBY frequency is put into the ACTIVE frequency windows by pressing the frequency transfer button. Either the standby frequency, the flight timer, or the elapsed timer is displayed in this position. The flight timer and elapsed timer are displayed replacing the standby frequency which goes into 'blind' memory to be called back at any time by depressing the FRQ button. Flight time or elapsed time are displayed and annunciated alternatively by depressing the FLT/ET button.

5. FLIGHT TIMER AND ELAPSED TIMER MODE ANNUNCIATION - Either the elapsed time (ET) or flight time (FLT) mode is annunciated here.
6. FREQUENCY SELECT KNOBS - Selects the standby frequency when FRQ is displayed and directly selects the active frequency whenever either of the time function is selected. The frequency selector knobs may be rotated either clockwise or counterclockwise. The small knob is pulled out to tune the 1's. The small knob is pushed in to tune the 10's. The outer knob tunes the 100's with rollover into the 1000's up to 1799. These knobs are also used to set the desired time when the elapsed timer is used in the countdown mode.
7. ON/OFF/VOLUME CONTROL SWITCH (ON/OFF/VOL) - Controls primary power and audio output level. Clockwise rotation from OFF position applies primary power to the receiver; further clockwise rotation increases audio level. Audio muting causes the audio output to be muted unless the receiver is locked on a valid station.
8. SET/RESET ELAPSED TIMER BUTTON (SET/RST) - The set/reset button when pressed resets the elapsed timer whether it is being displayed or not.
9. FLIGHT TIMER/ELAPSED TIMER MODE SELECTOR BUTTON (FLT/ET) - The Flight Timer/Elapsed Time mode selector button when pressed alternatively selects either Flight Timer mode or Elapsed Timer mode.
10. FREQUENCY TRANSFER BUTTON (FRQ) - The FRQ transfer button when pressed exchanges the active and standby frequencies. The new frequency becomes active and the former active frequency goes into standby.
11. BFO (Beat Frequency Oscillator) BUTTON - The BFO button selects the BFO mode when in the depressed position. (See note under item 3).
12. ADF BUTTON - The ADF button selects either the ANT mode or the ADF mode. The ANT mode is selected with the ADF button in the out position. The ADF mode is selected with the ADF button in the depressed position.
13. LUBBER LINE - Indicates magnetic heading of the airplane.

14. COMPASS CARD - Slaved Compass Card, derives its heading input from the Slaved Compass System KCS 55A.
15. BEARING POINTER - Indicates magnetic bearing to the station.
16. SYNC KNOB - The compass card is synchronized to the HSI compass card by rotating the SYNC knob until the heading matches that of the HSI.

OPERATING THE KR 87

TURN-ON

Rotate the ON/OFF/VOL knob clockwise from the detented 'OFF' position. The unit will be activated and will be ready to operate. Rotation of this control also adjusts audio volume. The KR 87 has 'audio muting' which causes the audio output to be muted unless the receiver is locked on a valid station.

FREQUENCY SELECTION

The active frequency (to which the ADF is tuned) is displayed in the left side of the window at all times. A standby frequency is displayed in the right side when 'FRQ' is annunciated. The standby frequency is placed in 'blind' memory when either FLT (Flight Time) or ET (Elapsed Time) mode is selected.

With 'FRQ' annunciated, the standby frequency is selected using the frequency select knobs which may be rotated either clockwise or counterclockwise. Pull the small inner knob out to tune 1's. Push the smaller inner knob to tune 10's. The outer knob tunes the 100's and the 1000's up to 1799.

The standby frequency selected may then be put into the active window by pressing the 'FRQ' button. The standby and active frequencies will be exchanged (flip-flopped), the new frequency will become active, and the former active frequency will go into standby.

OPERATING MODES

Antenna (ANT) mode is selected and annunciated when the 'ADF' button is in the 'out' position. ANT provides improved audio reception from the station tuned and is usually used for identification. The bearing pointer in the KI 227 indicator will be deactivated and immediately turn to the 90° relative position and remain there during ANT reception.

The ADF mode is selected and annunciated when the 'ADF' button is in the depressed position. ADF activates the bearing pointer in the KI 227 indicator, causing it to move without hesitation to the point in the direction of the station relative to the airplane heading. The compass card on the KI 227 may be rotated as desired by using the heading knob.

NOTE

The KI 227 indicator has a slaved compass card. The magnetic heading of the airplane will be under the lubber line. The indication of this compass card should be compared with that of the KI 525A master indicator from time to time. Check especially after steep bank turns and taxi turns. If a discrepancy between the two readings exists, the KI 227 compass card should be synchronized to the KI 525A compass card by rotating the 'SYNC' knob on the indicator.

Some stations are unmodulated and use an interrupted carrier for identification purposes. The BFO mode, activated and annunciated when the 'BFO' button is depressed, permits the carrier wave and the associated Morse code identifier broadcast on the carrier wave to be heard.

ADF TEST (PRE-FLIGHT OR IN-FLIGHT)

Select ANT mode. This will cause the bearing pointer to move directly to the parked 90° position. Make sure the unit is tuned to a useable frequency.

Now select ADF mode and the needle should move without hesitation to the station bearing. Excessive sluggishness, wavering or reversals indicate a signal that is too weak or a system malfunction.

OPERATING THE TIMERS

The flight timer will always be automatically reset to :00 whenever power is interrupted either by the avionics master switch or the unit's ON/OFF switch.

Flight time or elapsed time are displayed and annunciated alternatively by depressing the FLT/ET button. The flight timer continues to count up until the unit is turned off. The elapsed timer may be reset back to :00 by pressing the SET/RST button. It will then start counting up again.

NOTE

Pressing the SET/RST button will reset the elapsed timer whether it is being displayed or not.

The elapsed timer also has a 'count-down' mode. To enter the countdown mode, the SET/RST button is depressed for about two seconds, or until the 'ET' annunciation begins to flash. It is now in the ET set mode, and a time up to 59 minutes, 59 seconds may be preset into the elapsed timer with the concentric knobs.

The preset time will be displayed and remain unchanged until SET/RST is pressed again, which will start the elapsed timer counting down from the preset time. When the timer reaches :00 it will start to count up as the display flashes for 15 seconds and an aural alarm is activated for about 1 second.

NOTE

The standby frequency which is in memory while flight time or elapsed time modes are being displayed maybe called back by pressing the FRQ button, then transferred to active use by pressing the FRQ button again.

While FLT or ET is displayed the 'in use' frequency on the left side of the window may be changed, by using the frequency select knobs, without any effect on the stored standby frequency or the other modes. This feature is especially useful when searching for stations with unknown frequencies.

ERRONEOUS ADF BEARINGS DUE TO RADIO FREQUENCY PHENOMENA

STATION OVERLAP

In the U.S., the FCC, which assigns AM radio frequencies, occasionally will assign the same frequency to more than one station in an area. Certain conditions, such as Night Effect, may cause signals from such stations to overlap. This should be taken into consideration when using AM broadcast stations for navigation.

Sunspots and atmospheric phenomena may occasionally distort reception so that signals from two stations on the same frequency will overlap. For this reason it is always wise to make positive identification of the station being tuned, by switching the function selector to ANT and listening for station call letters.

ELECTRICAL STORMS

In the vicinity of electrical storms, an ADF Indicator pointer tends to swing from the station tuned toward the electrical discharges. Location of the storm can be useful information, but the erratic behavior of the pointer should be taken into account.

NIGHT EFFECT

This is a disturbance particularly strong just after sunset and just after dawn. An ADF indicator pointer may swing erratically at these times. If possible, tune to the most powerful station at the lowest frequency. If this is not possible, take the average of pointer oscillations to determine relative station bearing.

MOUNTAIN EFFECT

Radio waves reflecting from the surface of mountains may cause the pointer to fluctuate or show an erroneous bearing. This should be taken into account when taking bearings over mountainous terrain.

COASTAL REFRACTION

Radio waves may be refracted when passing from land to sea or when moving parallel to the coastline. This should be taken into account when operating near coastal areas.

8. AIRPLANE HANDLING, CARE AND MAINTENANCE

No change.