

RECOMMENDED SERVICE BULLETIN

RSB 40NG-052

I TECHNICAL DETAILS

I.1 Category

Recommended.

I.2 Airplanes affected

Type: DA 40 NG,

Serial numbers: 40.N001 through 40.N323

Applies to all aircraft equipped with OÄM 40-314 additional alternator.

I.3 Date of effectivity

08-Mar-2017

I.4 Time of Compliance

At owner's discretion.

I.5 Subject

Improved mounting of 2nd Alternator.

ATA-Code: 24-33

I.6 Reason

In order to reduce wear on the mounting arm, this Service Bulletin describes all measures necessary for modifying the attachment to the engine mounting arm.

I.7 Concurrent Documents

None.

I.8 Approval

The technical information or instructions contained in this document relate to the Design Change Advisory No. OÄM 40-314/t, which has been approved under the authority of EASA Design Organization Approval ref. EASA.21J.052.

The technical content of this document has been approved under the authority of DOA ref. EASA.21J.052.

I.9 Accomplishments / Instructions

WI-OSB 40NG-052, latest effective issue.

I.10 Mass (Weight) and CG

None.

II PLANNING INFORMATION**II.1 Material and Availability**

See WI-RSB 40NG-052, latest effective issue.

II.2 Special Tools

None.

II.3 Labour Effort

Approx. 4 hours without cure time.

II.4 Credit

None.

II.5 Reference Documents

DA 40 NG Airplane Maintenance Manual, Doc. No. 6.02.15, latest effective issue.

III REMARKS

1. All work must be done by a certified aircraft service station or a certified aircraft maintenance mechanic.
2. All work, in particular that which is not especially described in this Service Bulletin, must be done in accordance with the referenced Maintenance Manual.
3. Completion of all work must be recorded in the log book.
4. In case of doubt contact Diamond Aircraft Industries GmbH.

EXECUTION REPORT TO SERVICE BULLETIN RSB 40NG-052

AIRPLANE INFORMATION

Airplane Serial Number _____

Airplane Registration _____

Airplane Operator _____

Hours of operation of airplane _____

No. of landings _____

Hours of operation-engine _____

Typical operation of airplane private, club, training, other _____

Date, Name, Sign

Please fax the completed form to Fax No. +43-2622-26780 or e-mail to
executionreports@diamond-air.at

WORK INSTRUCTION

WI-RSB 40NG-052

I GENERAL INFORMATION

I.1 Subject

Improved mounting of 2nd Alternator.

I.2 Reference Documents

DA 40 NG Airplane Maintenance Manual, Doc. No. 6.02.15, latest effective issue

I.3 Remarks

- a) All work must be done by a certified aircraft service station or a certified aircraft maintenance mechanic.
- b) All work, in particular that which is not especially described in this work instruction, must be done in accordance with the referenced maintenance manual.
- c) In case of doubt, contact Diamond Aircraft Industries GmbH.

II DRAWINGS, SPECIAL TOOLS & MATERIALS

II.1 Drawings

None

II.2 Special Tools

Reamer 15 H7

Recommended tension gauge: CONTI® VSM-1

V-Belt tension device D44-6116-00-00-SW

II.3 Material

Quantity	Part No.	Description	Pos
1	LN 9338-06	Nut Hexagon, self-locking	1
1	DIN 9021-6,4-A2	Washer	2
1	D64-7106-11-30_01	Outer Alternator Bushing	3
1	D64-7106-11-31	Inner Alternator Bushing	4
1	LN 9037-M6x42	Screw, hexagon Head	5
1	MS 21042-6	Nut Double Hex, self-locking	6
1	NL3/8-SPSS	Locking Washer	7
1	NL3/8-SS	Locking Washer	8
1	AN6-12A	Bolt, Machine, Aircraft	9
1	D64-2416-30-30	Alternator Bushing	10

Material is available from Diamond Aircraft Industries.

III INSTRUCTIONS

1	Remove engine cowlings i.a.w. AMM section 71-10.
2	Disconnect the battery and ECU backup batteries for maintenance i.a.w. AMM section 24-31.
3	Remove the additional alternator i.a.w. AMM section 61-10.
4	Check the engine mounting arm for excessive wear on the rear attachment point, if the mounting hole diameter greater than 11 mm, replace the engine mounting arm i.a.w. AMM section 71-00.

Remove the lower rear mounting bushing from the alternator housing.
Note: Support the surrounding alternator housing from the opposite side to prevent damage.

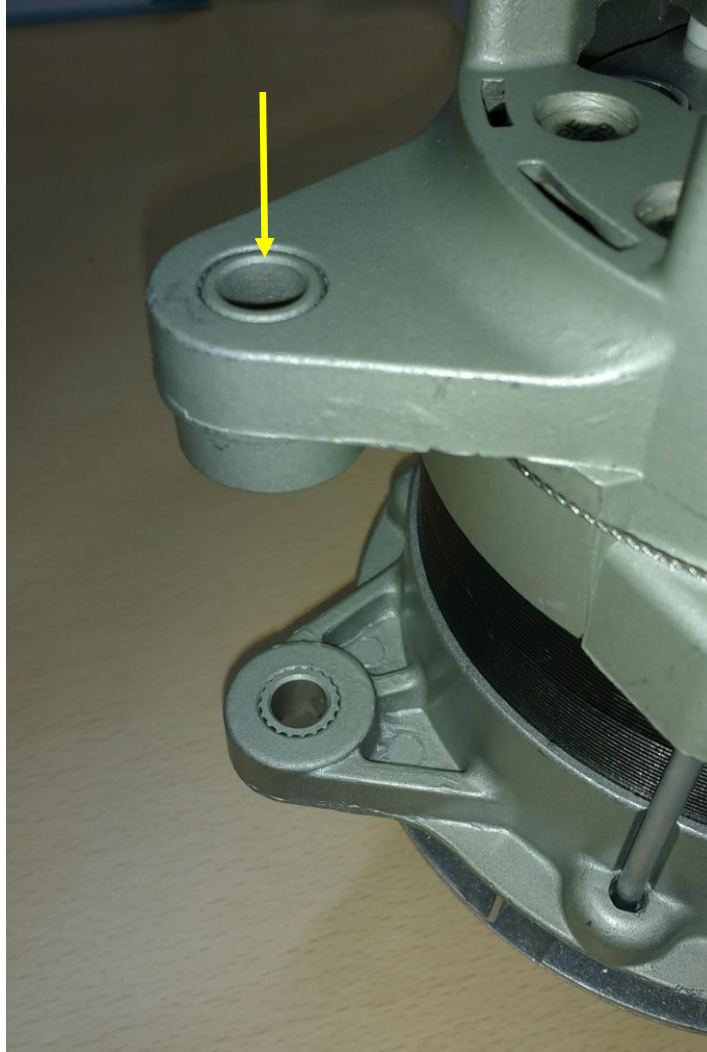

5

- | | |
|---|--|
| 6 | Ream the alternator housing with a 15H7 reamer.
Caution: Take care that no swarf from reaming gets into the alternator. |
| 7 | Prepare the alternator housing and the bushing D64-2416-30-30 for bonding. |

Use Loctite 638 for the bushing installation.

8



9

Fix the bushing with a bar clamp on the alternator and support the over length of the bushing with a 16 mm washer or equivalent.

10

Cure the Loctite 638 for 3 hours.

11 Install the alternator i.a.w. figure below (Position numbers i.a.w. material list II.3).
 Apply AeroShell Grease 5 (or equivalent) on the surface of pos 3 before installation.

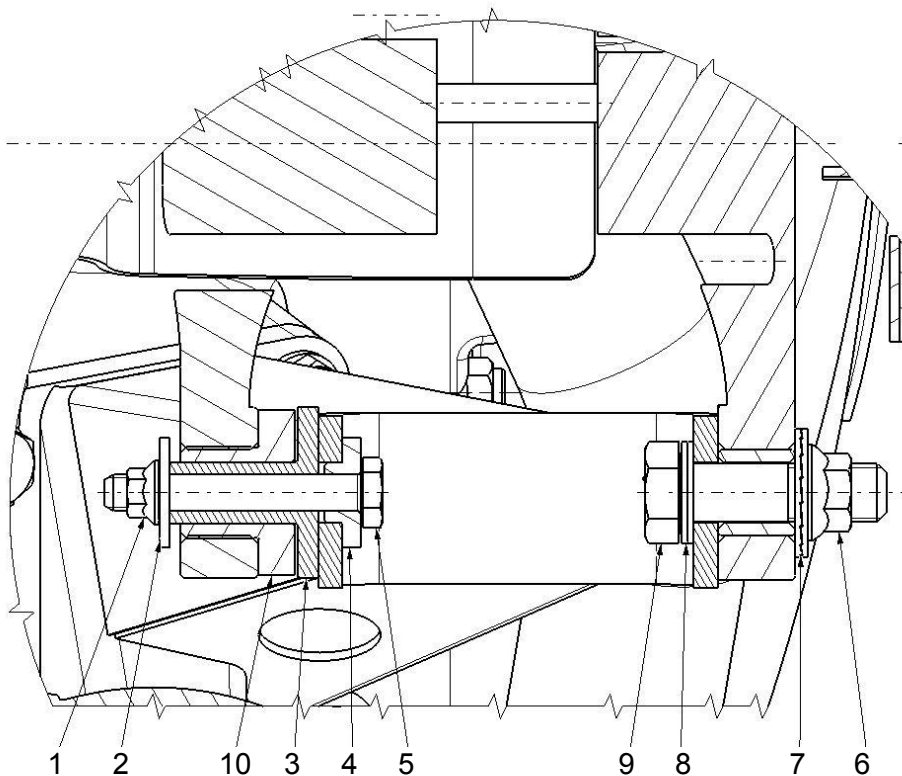

12 Install the V-Belt and adjust tension of the Additional Alternator i.a.w. AMM Section 61-10. Tighten the highlighted bolts (orange) 25+/-3 Nm.

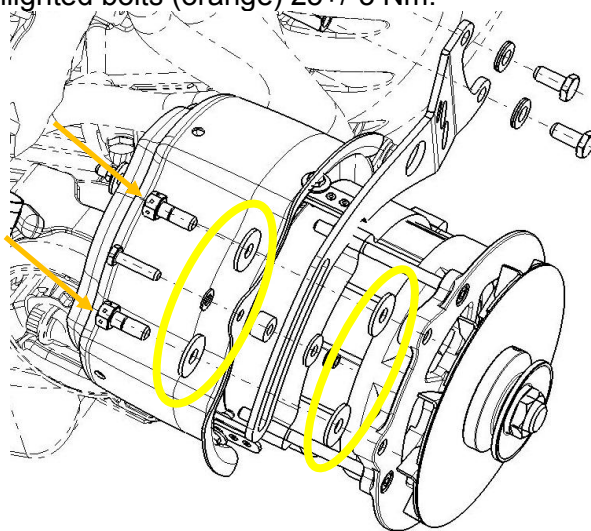

Caution: Make sure that there are 4 washers installed.
 Make sure that the alternator cable is fixed with cable ties.
 Make sure that the coolant hose from the heat exchanger has sufficient clearance.

13 Connect the battery and ECU backup batteries for maintenance i.a.w. AMM Section 24-31.

14 Install engine cowlings i.a.w. AMM section 71-10.

15	Minimum 24 hours after bonding of the alternator bushing do an engine run-up and test the propeller and alternator for correct operation.
16	Clean working areas, check for foreign objects.
17	Check all altered, replaced, repaired parts for proper function.
18	Test all systems in working area for function.
19	Make all necessary entries in the airplane logs.