

SERVICE INFORMATION

NO. SI 20E-015

I TECHNICAL DETAILS

I.1 Airplanes affected

Type: DV 20 E,
all airplanes with ROTAX 912 iSc installed

I.2 Subject

BRP-Rotax GmbH & Co KG Service Bulletin SB-912 i-016
ATA-Code: 24-20

I.3 Reason

BRP-Rotax GmbH & Co KG has issued Service Bulletin No. SB-912 i-016 mandating an inspection and/or replacement of oil spray nozzle for ROTAX® Engine Type 912 i for serial numbers and overhaul-kits as listed.

I.4 Information

For detailed technical information refer to BRP-Rotax GmbH & Co KG Service Bulletin SB-912 i-016 which is applicable without any further additions or restrictions.

II REMARKS

1. BRP-Rotax GmbH & Co KG Service Bulletin SB-912 i-016 is attached to this Service Information.
2. In case of doubt contact BRP-Rotax GmbH & Co KG.
3. For detailed information of the Service Information System refer to SI 20-100 latest issue.

Inspection and/or replacement of oil spray nozzle for ROTAX® Engine Type 912 i, 915 i and 916 i (Series)

ATA System: 24-20-00 Internal generator

MANDATORY*

* This Service Bulletin could be subject to an EASA airworthiness directive (AD).

1) Planning information

To obtain satisfactory results, procedures specified in this publication must be accomplished with accepted methods in accordance with prevailing legal regulations.

BRP-Rotax GmbH & Co KG cannot accept any responsibility for the quality of work performed in accomplishing the requirements of this publication.

1.1) Applicability

All engines of Series 912 iSc Sport, 915 iSc A, 915 iSc C24, 916 iSc A, 916 iSc C24 and 916 iSc B are affected if at least one of following criteria applies:

Criterion A) Engine production date and S/N:

These engines have been originally delivered from the factory with the possibility of blockage of the oil spray nozzle:

NOTE: Engine S/Ns from the list below with minimum 200 hours of operation are excluded from this Service Bulletin as cooling of the stator is sufficient.

Engine type	Serial number
912 iSc Sport	from S/N 7702217 up to S/N 10008922 inclusive
915 iSc A	from S/N 9127550 up to S/N 10008739 inclusive
915 iSc C24	from S/N 9152016 up to S/N 10002607 inclusive
916 iSc A	from S/N 9148004 up to S/N 10006944 inclusive
916 iSc C24	from S/N 10002846 up to S/N 10006286 inclusive
916 iSc B	from S/N 10001198 up to S/N 10008794 inclusive

Criterion B) Spare parts:

Further all engines are affected which have been equipped with overhaul kits with engine blocks part no.:

- 893246 OVERHAUL-KIT 912 iS W. ENGINE BLOCK
- 893249 OVERHAUL-KIT 915 iS W. ENGINE BLOCK

during engine repair, maintenance or general overhaul, delivered as spare parts from January 1st, 2022 up to October 31st, 2024 included.

e07006.fm

SERVICE BULLETIN

1.2) Concurrent ASB/SB/SI and SL

In addition to this Service Bulletin the following documents must be observed and complied with:

- SI-912 i-011 Maintenance information on plug screw M22x1.5 part no. 940520 for ROTAX 912 i Series
- SI 912 i-028, SI-915 i-008 Change of oil cooling of stator for ROTAX® Engine Type 915 i A (Series) and 912 i (Series).
- SI-912 i-001,SI-912-016,SI-914-019,SI-915 i-001,SI-916 i-001 Selection of suitable operating fluids for Rotax Engine Type 916 i (Series), 915 i (Series), 912 i (Series), 912 and 914 (Series).
- in general, all relevant Alert Service Bulletins (ASB), Service Bulletins (SB), Service Instructions (SI), Service Letters (SL), Service Instruction - Parts and Accessories (SI-PAC) with relevance to perform this maintenance, repair or overhaul task.

1.3) Reason

Due to a deviation in the manufacturing process, excessive application of LOCTITE at the sprag clutch housing and/or oil spray nozzle may lead to blockage of the nozzle. This could lead to inadequate cooling and possible damage to the stator assy. up to failing of one LANE.

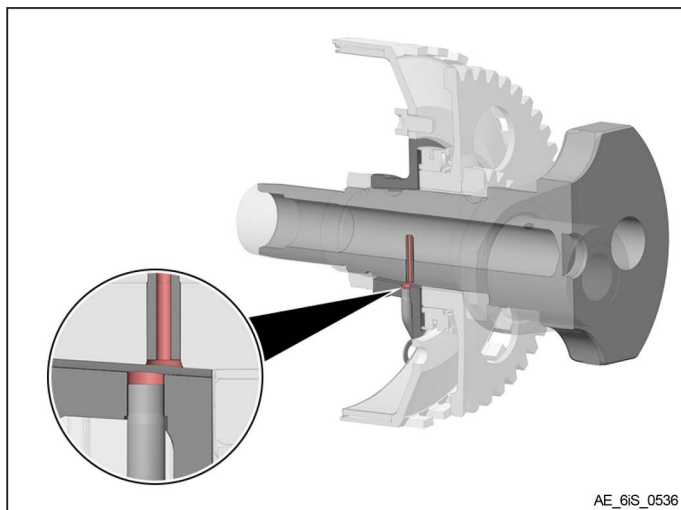

Fig. 1

1.4) Subject

Inspection and/or replacement of oil spray nozzle for ROTAX® Engine Type 912 i, 915 i and 916 i (Series).

SERVICE BULLETIN

1.5) Compliance

- On undelivered engines / spare parts prior to delivery
- Before the initial installation of the engine / spare part
- At next scheduled maintenance event or at least within the next 25 hours of operation carry out this check of the oil spray nozzle on the engines listed in section 1.1) according to the following instructions in section 3, but at the latest after 1 year (from the date of the initial issue of this Service Bulletin).



WARNING

Non-compliance with these instructions could result in engine damages, personal injuries or death.

1.6) Approval

The technical content of this document is approved under the authority of the DOA ref. EASA.21J.048.

1.7) Labor time

A labor credit will be provided for work performed by a technician with current applicable iRMT rating.

Work performed	iRMT rating required	Labor credit
Inspect oil spray nozzle on aircraft	Maintenance Line	1.2 hr per inspection
Cleaning of oil spray nozzle on aircraft	Maintenance Heavy	7.3 hr per replacement

To apply for labor credit, contact your ROTAX® Authorized Distributor or their independent Service Centers.

1.8) Mass data

Change of weight - - - none

Moment of inertia - - - unaffected

1.9) Electrical load data

No change.

1.10) Software modifications

No change.

SERVICE BULLETIN

1.11) References

In addition to this technical information refer to current issue of

- In general Illustrated Parts Catalog (IPC) and in particular Chapters 72-20-00 & 24-20-00
- In general Operators Manual (OM)
- In general Installation Manual (IM)
- In general Maintenance Manual Line (MML) and in particular Chapter 12-20-00
- In general Maintenance Manual Heavy (MMH) and in particular Chapters 24-20-00, 72-20-00, 75-00-00 & 80-10-00

NOTE: The status of the Manuals can be determined by checking the table of amendments. The 1st column of this table shows the revision status. Compare this number to the one listed on the ROTAX® website:
www.flyrotax.com. Updates and current revisions can be downloaded for free.

1.12) Other Publications affected

None

1.13) Interchangeability of parts

None.

SERVICE BULLETIN

2) Material Information

2.1) Material

Price and availability will be provided on request by ROTAX® Authorized Distributors or their independent Service Centers.

2.2) Company support information

- Any possible support by BRP-Rotax will be provided on request by ROTAX® Authorized Distributors or their independent Service Centers
- This exchange program and cost sharing is valid until December 31st 2025. Up to this date limited reimbursement of costs can be applied for
- Shipping costs, downtime costs, loss of income, telephone costs etc. or costs of conversion to other engine versions or additional work, as for instance simultaneous engine overhauls are not covered in this scope and will not be borne or reimbursed by ROTAX®.

2.3) Material requirement per engine

Parts requirement for inspection, see Fig. 2.

Fig.no.	Part no.	Qty/ engine	Description	Application
2-1	950141	1	SEALING RING A 8X13	Locking pin bolt
2-2	430225*	(1)	O-RING - 15.9X2.3	Plug screw *
2-3	250057**	(1)	O-RING - 18X2.5	Plug screw **
-	-	AR	ENGINE OIL XPS / AEROSHELL SPORT PLUS 4	Oil level check

* only applicable to 912i Series

** only applicable to 915i and 916i Series

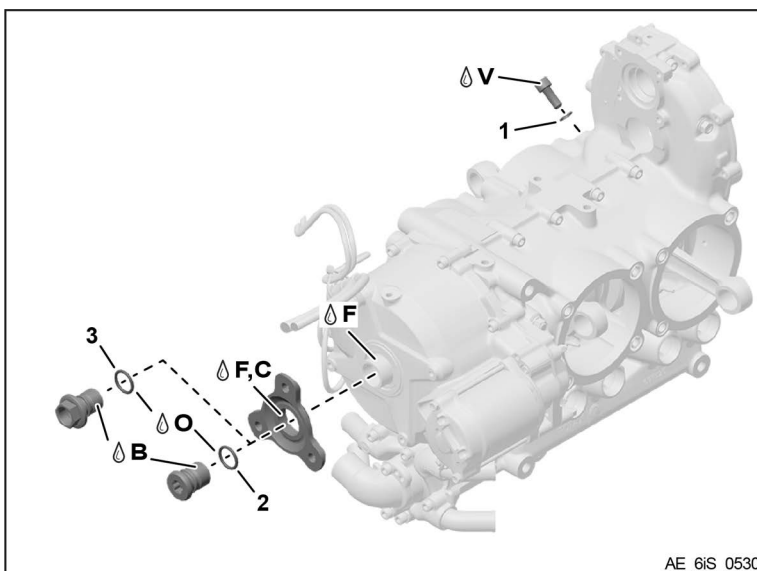

Fig. 2

d07006.fm

SERVICE BULLETIN

Parts requirement for cleaning and replacement, see Fig. 3:

Fig.no.	Part no.	Qty/ engine	Description	Application
3-1	831929	1	O-RING 5X2	Ignition housing
3-2	246055	1	WOODRUFF KEY	Crankshaft / sprag clutch
3-3	456540	1	OIL SPRAY NOZZLE ASSY.	Sprag clutch housing
3-4	230429	1	OIL SEAL	Ignition housing
3-5	850983	(1)	GASKET	Water pump housing
3-6	230415	(1)	SEALING RING A 6X10	Water pump drain screw
-	i	AR	ENGINE OIL XPS / AEROSHELL SPORT PLUS 4	Oil level check
-	i	AR	ENGINE COOLANT	Coolant level check

ⁱ See SI-912 i-001,SI-912-016,SI-914-019,SI-915 i-001,SI-916 i-001 Selection of suitable operating fluids for Rotax Engine Type 916 i (Series), 915 i (Series), 912 i (Series), 912 and 914 (Series).

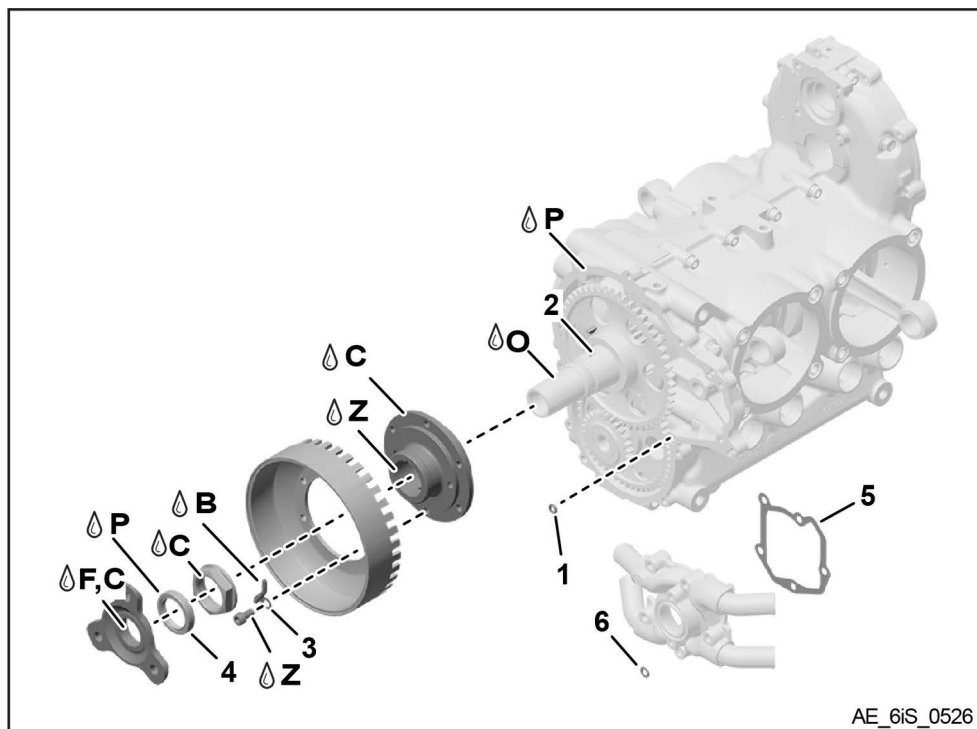

Fig. 3

d07006.fm

SERVICE BULLETIN

2.4) Special tooling/lubricants- /adhesives- /sealing compounds

Part no.	Description	Application
240880	LOCKING PIN	Crankshaft locking
876010	PULLER ASSY.	Ignition housing
877375	PULLER ASSY.	Sprag clutch assy.
877419	PROTECTION MUSHROOM	Puller assy.
876020	INSERTION JIG	Ignition housing, oil seal
976740	TEST TOOL OIL SPRAY NOZZLE ASSY.	Blockage test
-	FLOW-METER (0 - 10 l/min) digital or analog (for operating medium of compressed air and with an unidirectional flow)	Blockage test
-	PNEUMATIC PRESSURE REGULATOR (pressure regulation range 0,1 bar to 6 bar)	Blockage test
-	PNEUMATIC SHUT OFF VALVE	Blockage test
-	ALLEN SCREW M6x120	Blockage test
897651	LOCTITE 243 BLUE. 10 CC. (B)	Oil spray nozzle
899788	LOCTITE 648 GREEN. 5 CC (C)	Hex. nut
297438	LOCTITE ANTI SEIZE 8151 400 ML (E)	Sprag clutch
-	LOCTITE 7063 (F)	Cleaner / degreaser for oil spray nozzle
-	ENGINE OIL (O)	Crankshaft
899791	LOCTITE 5910. 50 ML (P)	Ignition housing, oil seal
898570	LOCKING PAINT 20 ML (V)	Lock pin, Allen screw
899789	LOCTITE 603 GREEN. 10 CC. (Z)	Sprag clutch assy.

SERVICE BULLETIN

3) Accomplishment/Instructions

- ROTAX® reserves the right to make any amendments to existing documents, which might become necessary due to this standardization, at the time of next revision or issue.

NOTE: Before maintenance, review the entire documentation to make sure you have a complete understanding of the procedure and requirements.

Accomplishment

All measures must be implemented and confirmed by at least one of the following persons or organizations:

- ROTAX® - Airworthiness representatives
- ROTAX® - Authorized Distributors or their independent Service Centers
- Persons approved by the respective Aviation Authorities
- Persons with approved qualifications for the corresponding engine types. Only authorized persons (iRMT, Level Line / Heavy Maintenance) are entitled to carry out this work
- Persons with type-specific training

NOTE: Indicates supplementary information which may be needed to fully complete or understand an instruction.



All work has to be performed in accordance with the relevant ROTAX® Instructions for Continued Airworthiness (ICA) of the respective engine type.

General

Further material on general inspection, maintenance and repair can also be found in relevant Advisory Circular AC 43.13 from FAA.

Advisory Circular

The Advisory Circular (AC) contains maintenance methods, techniques and practices.

Procedure

Step	Procedure
1	Check the criteria given on page 1, section 1.1, if the aircraft engine or spare part is affected by this SB.
2	Check the engine logbook and maintenance documentation, if this SB has already been accomplished.

3.1) Illustrated Parts Catalog - related information



See current Illustrated Parts Catalog (IPC) for the respective engine type, Chapters 72-20-00 & 24-20-00.

3.2) Installation - related information



See current Installation Manual (IM) for the respective engine type.

SERVICE BULLETIN

3.3) Operation - related information



See current Operators Manual (OM) for the respective engine type.
 See also Aircraft Flight Manual (AFM) / Pilot Operating Handbook (POH).

3.4) Maintenance (Line) - related information

3.4.1) Inspection of oil spray nozzle

See Fig. 4

Step	Procedure
1	Lock the crankshaft. See current Maintenance Manual Line (MML) for the respective engine type, Chapter 12-20-00, Section Locking / loosen of the crankshaft.
2	Loosen plug screw (1 or 2).
3	If equipped, remove the optional generator flange assy. (3). See current Maintenance Manual Heavy (MMH) for the respective engine type, Chapter 72-20-00 and SI-PAC-023.

- 1 Plug screw 915 i/916 i (Series)
- 2 Plug screw 912 i (Series)
- 3 Generator flange assy. (optional part)

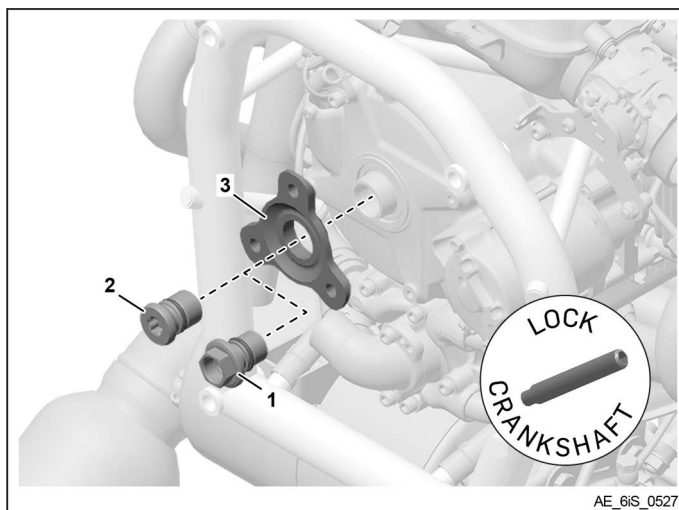
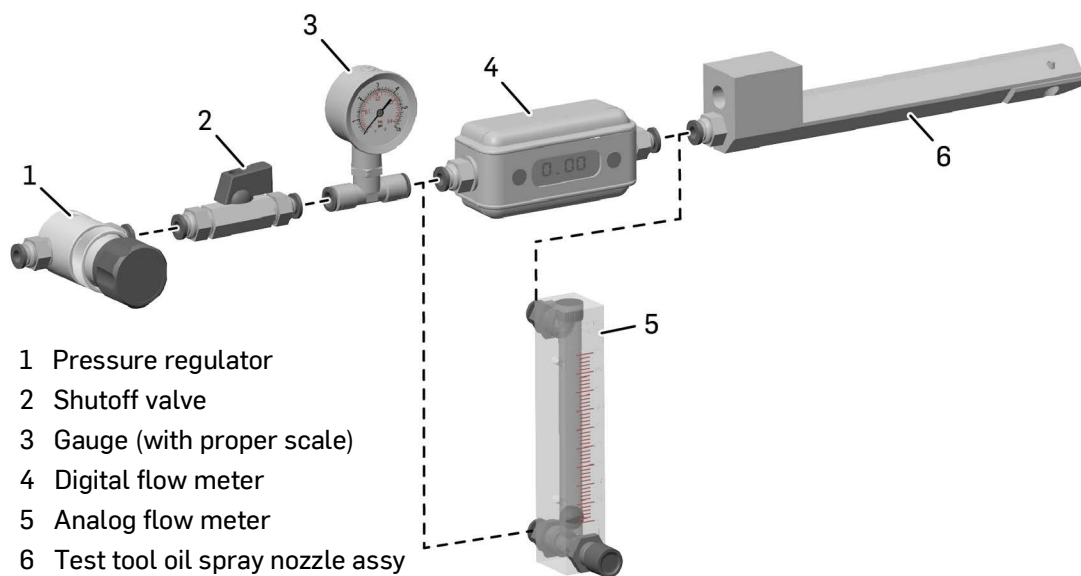

Fig. 4

SERVICE BULLETIN

See Fig. 5

Step	Procedure
4	Attach a pressure regulator (1), shutoff valve (2) and a flow meter (4 or 5) to the measurement adapter tool. NOTE: For measurement a flow meter is required, either a digital or analog one; if using an analog type, this one needs to be in vertical position while the measurement is done, otherwise the measurement will be inaccurate.
5	Connect the regulator (1) input to a compressed air source.
6	Open the shutoff valve (2) and set the regulator (1) to 300 mbar (4.35 psi). close the shutoff valve.



AE_6iS_0545

Fig. 5

SERVICE BULLETIN

See Fig. 6

Step	Procedure
7	Carefully insert the measurement adapter tool (1) into the crankshaft, capturing the internal oil nipple (2).
8	Slide the rod (3) into the tool until approximately 25 mm (0.98 in.) is still protruding from the tool.

- 1 Adapter tool
- 2 Oil nipple
- 3 Rod
(e.g. Allen screw M6x120 - not
scope of delivery)

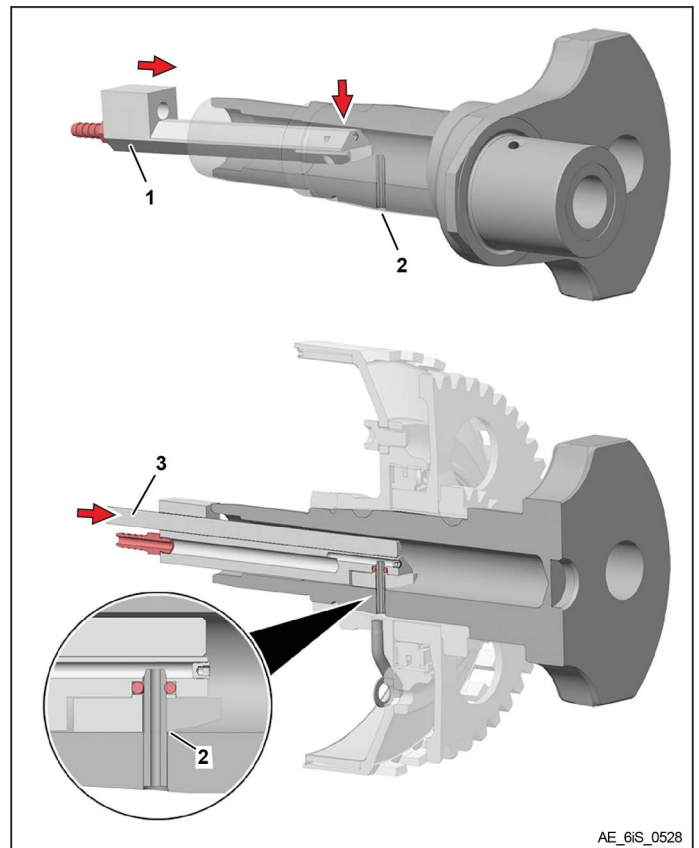

Fig. 6

SERVICE BULLETIN

See Fig. 7

Step	Procedure
9	Open shutoff valve and record the flow reading.
10	If the flow reading is < 4 l/min (1.05 gal/min), the oil spray nozzle is un-serviceable. Continue to Section 3.5 .
11	If the flow reading is ≥ 4 l/min (1.05 gal/min), the oil spray nozzle is serviceable.
12	Remove the test tool oil spray nozzle assy.
13	If equipped, install the optional generator flange assy. (4). See current Maintenance Manual Heavy (MMH) for the respective engine type, Chapter 72-20-00 and SI-PAC-023.
14	Install plug screw (1 or 2) with a new O-ring (3). See current Maintenance Manual Heavy (MMH) for the respective engine type, Chapter 24-20-00, Section Installation.
15	Remove locking pin and install Allen screw M8x20 (5) with new sealing ring A 8x13 (6). See current Maintenance Manual Line (MML) for the respective engine type, Chapter 12-20-00, Section Locking / loosen of the crankshaft. Continue to Section 3.6 .

- 1 Plug screw 915 i / 916 i
- 2 Plug screw 912 i
- 3 O-ring
- 4 Generator flange assy.
- 5 Allen screw M8x20
- 6 Sealing ring A 8X13

- B - LOCTITE 243
- C - LOCTITE 648
- F - LOCTITE 7063
- O - Engine oil
- V - Locking paint

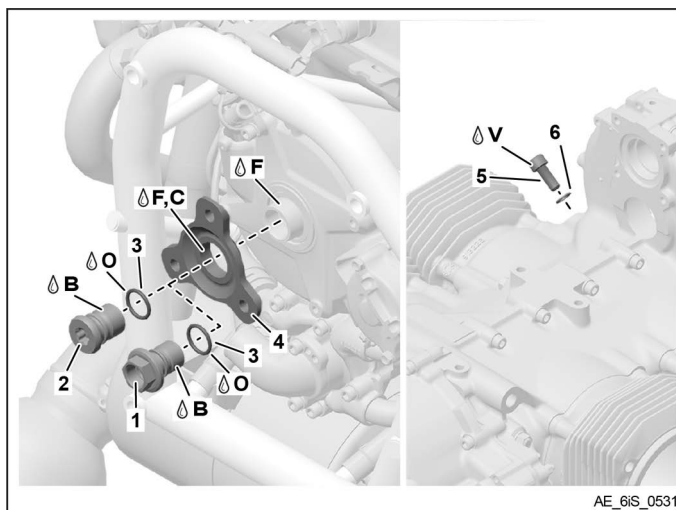

Fig. 7

SERVICE BULLETIN

3.5) Maintenance (Heavy) - related information (only applicable if the oil spray nozzle is classified as un-serviceable as per inspection in section 3.4.1)

3.5.1) Inspection of stator assy.

See Fig. 7

Step	Procedure
1	Drain the engine coolant. See current Maintenance Manual Line (MML) for the respective engine type, Chapter 12-20-00, Section Cooling System.
2	Remove the water pump housing. See current Maintenance Manual Heavy (MMH) for the respective engine type, Chapter 75-00-00.
3	Remove the electric starter. See current Maintenance Manual Heavy (MMH) for the respective engine type, Chapter 80-10-00.
4	Remove the ignition housing. See current Maintenance Manual Heavy (MMH) for the respective engine type, Chapter 24-20-00.
5	Visually inspect the stator and wiring for signs of overheating or discoloration.
6	Check the resistance value of generators A and B. See current Maintenance Manual Heavy (MMH) for the respective engine type, Chapter 24-20-00.
7	If the stator shows signs of discoloration or overheating and/or the resistance values are outside of the nominal range, the stator assy. is un-serviceable and must be replaced.

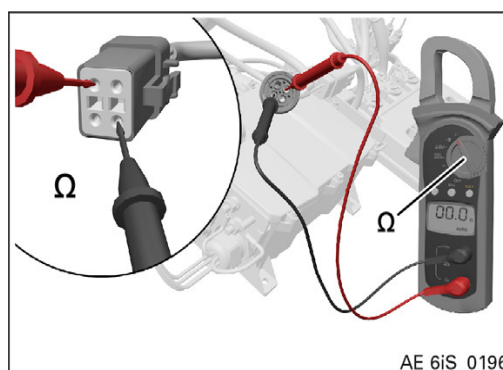

Fig. 8

Limit	(Phase -1 to Phase -2)	(Phase -1 to Phase -3)	(Phase -2 to Phase -3)
	[Ohms]	[Ohms]	[Ohms]
GEN A	0.6	0.6	0.6
GEN B	0.3 - 0.4	0.3 - 0.4	0.3 - 0.4

d07006.fm

SERVICE BULLETIN

3.5.2) Replacement of oil spray nozzle

Disassembly:

See Fig. 9

Step	Procedure
1	Remove the magneto flywheel assy. (1), sprag clutch assy. (2) and oil spray nozzle (3). Disassemble sprag clutch assy. See current Maintenance Manual Heavy (MMH) for the respective engine type, Chapter 74-20-00.

- 1 Magneto flywheel assy.
- 2 Sprag clutch assy.
- 3 Oil spray nozzle

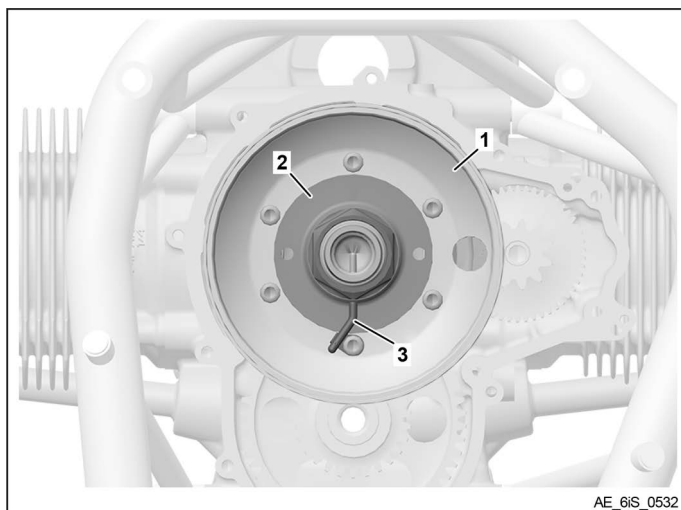

Fig. 9

Cleaning:

See Fig. 10

Step	Procedure
1	Clean residual LOCTITE from all threads and contact surfaces.
2	Clean the sprag clutch housing oil bore (1) with LOCTITE 7063 (F).
3	If necessary, clean the crankshaft oil spray nozzle (2) using a 1.2 mm (0.047 in.) hand drill followed by a punch ground to a diameter of 1.45 mm (0.057 in.) and LOCTITE 7063 (F) from the top side of crankshaft (outer diameter) to the internal side of crankshaft. NOTE: Remove any residual from the internal diameter of the crankshaft.

d07006.fm

SERVICE BULLETIN

- 1 Sprag clutch housing oil bore
- 2 Crankshaft oil spray nozzle

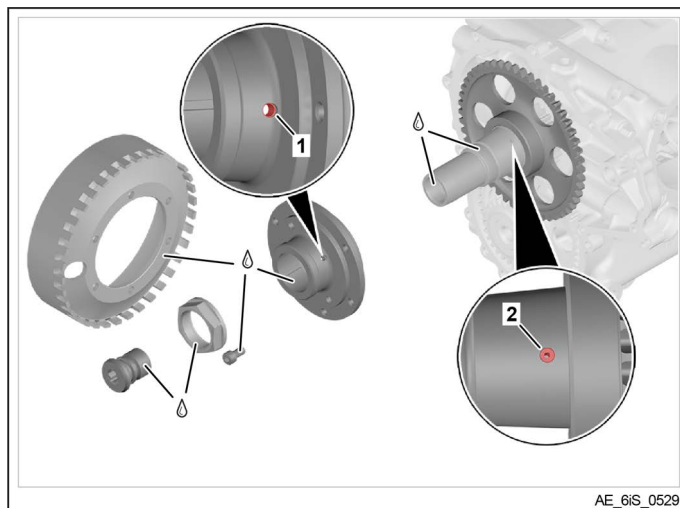

Fig. 10 (TYPICAL)

Assembly:
 See Fig. 11 and 12

Step	Procedure
1	Assemble and install the sprag clutch assy. (1) and the magneto flywheel (2) along with a new oil spray nozzle part no. 456540 (3). See current Maintenance Manual Heavy (MMH) for the respective engine type, Chapter 74-20-00.

- 1 Sprag clutch assy.
- 2 Magneto flywheel
- 3 Oil spray nozzle

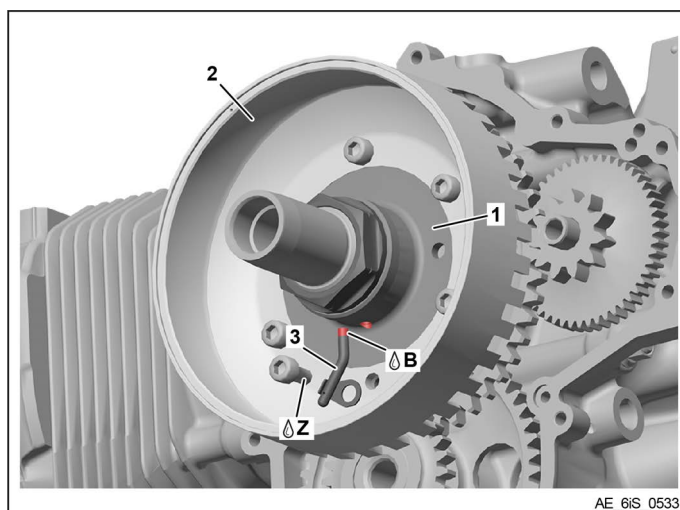

Fig. 11

NOTICE

Do not apply excessive amounts of LOCTITE to prevent oil spray nozzle from clogging. Clean bore with brake cleaning fluid before installation.

d07006.fm

SERVICE BULLETIN

Step	Procedure
2	Perform the oil spray nozzle inspection as in section 3.4.1 . NOTE: If minimum airflow value is not achieved, contact the ROTAX® Authorized Distributor of your area.
3	Remove the TEST TOOL OIL SPRAY NOZZLE ASSY.
4	Install the ignition housing. See current Maintenance Manual Heavy (MMH) for the respective engine type, Chapter 24-20-00.
5	Install the water pump housing. See current Maintenance Manual Heavy (MMH) for the respective engine type, Chapter 75-00-00.
6	Install the electric starter. See current Maintenance Manual Heavy (MMH) for the respective engine type, Chapter 80-10-00.
7	If equipped, install the optional generator flange assy. (7). See current Maintenance Manual Heavy (MMH) for the respective engine type, Chapter 72-20-00 and SI-PAC-023.
8	Install plug screw (4 or 5) with a new O-ring (6), see current Maintenance Manual Heavy (MMH) for the respective engine type, Chapter 24-20-00, section Installation.
9	Remove locking pin and install Allen screw M8x20 (8) with new sealing ring A 8x13 (9), see current Maintenance Manual Line (MML) for the respective engine type, Chapter 12-20-00, section Locking / loosen of the crankshaft.
10	Replenish operating fluids or check filling levels, see current Maintenance Manual Line (MML) for the respective engine type, Chapter 12-10-00 section Coolant check/replenish and Oil level check/replenish.
11	Purge the oil system, see current Installation Manual (IM) for the respective engine type, Chapter 79-00-00, section Purging the lubrication system.
12	Make an entry in the engine logbook stating the execution of this Service Bulletin and the inspection findings.
13	Perform a leakage check of the whole system, see current Maintenance Manual Line (MML) for the respective engine type, Chapter 12-20-00, section Leakage check.

d07006.fm

SERVICE BULLETIN

- 4 Plug screw 915 i / 916 i
- 5 Plug screw 912 i
- 6 O-ring
- 7 Generator flange assy.
- 8 Allen screw M8x20
- 9 Sealing ring A 8X13

- B - LOCTITE 243
- C - LOCTITE 648
- F - LOCTITE 7063
- O - Engine oil
- V - Locking paint

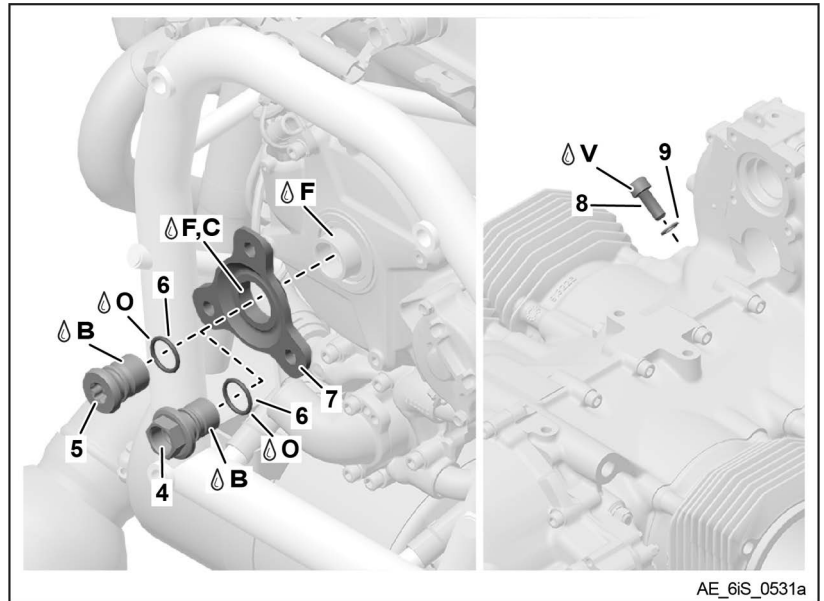

Fig. 12

SERVICE BULLETIN

3.6) Finishing work

- Restore aircraft to original operating configuration.
- Connect negative terminal of aircraft battery.

3.7) Test run

Conduct test run.

In case of uninstalled engines test run is accomplished with the mandatory test run after installation into aircraft.



See Chapter 12-20-00 of the latest Maintenance Manual Line (MML) for the respective engine type.

3.8) Summary

These instructions (section 3) have to be followed in accordance with the deadlines specified in section 1.5.

The execution of the mandatory Service Bulletin must be confirmed in the logbook.

NOTE: Work on EASA certified parts might affect the EASA Form 1 and does require appropriate documentation by authorized persons. Repairs must be entered into the engine logbook and also do apply for the EASA Form 1.

| A revision bar outside of the page margin indicates a change to text or graphic.

Translation into other languages might be performed in the course of language localization but does not lie within ROTAX® scope of responsibility.

In any case the original text in English language and the metric units are authoritative.

3.9) Inquiries

Inquiries regarding this Service Bulletin should be sent to the ROTAX® Authorized Distributor of your area.

A list of all ROTAX® Authorized Distributors or their independent Service Centers is provided on <https://dealerlocator.flyrotax.com>.