

SERVICE INFORMATION LETTER



Page: 1 of 2
07 Oct 10

SERVICE INFORMATION LETTER NO. SIL20C1-005

NOTE: Service Information Letters are used only:

1. To distribute information from Diamond Aircraft Industries (DAI) to our customers.
2. To distribute applicable information/documents from our suppliers to our customers with additional information.

NOTE: Typically there is no revision service for Service Information Letter (SIL). Each new information or change will be sent along with a new SIL.

1. TECHNICAL DETAILS

1.1 Aircraft Affected

DA20-C1 aircraft from S/N C0001 to C0571.

1.2 Subject

The improvement in the design of the Nose Landing Gear (NLG) Fork assembly. The old P/N 20-3220-08-00 has been replaced with the new NLG Fork assembly, P/N 20-3220-08-00_1.

1.3 Reason

Cracks have been found on some NLG Fork assembly, P/N 20-3220-08-00 during routine inspections. Cracking usually occurs on higher time aircraft but could occur sooner with rough field operations or hard landings. Figure 1 shows where the cracking has normally occurred. Also, the machine screw, pan head, P/N MS35207-282 (see Figure 1) should be installed with Loctite 242 when the wheel fairings are not used to avoid any potential cracking that may occur at that location.

1.4 Information

Refer to DA20-C1 Aircraft Maintenance Manual (AMM) Document No. DA201-C1, Revision 17 dated 01 November 2010 or later revisions for new inspection requirements for the NLG and the Illustrated Parts Catalogue (IPC), Document No. DA203-C1, Revision 8 dated 15 November 2010 or later approved revisions.

2. OTHERS

Contact DAI or your local authorized Diamond Service Center.

SERVICE INFORMATION LETTER



Page: 2 of 2
07 Oct 10

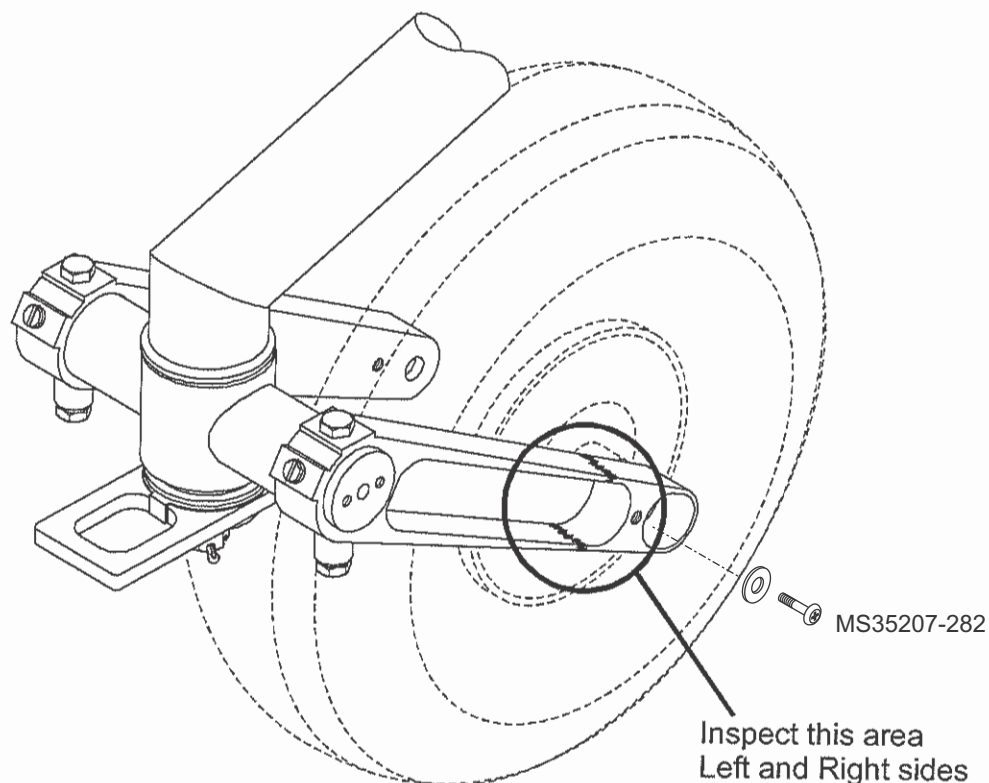

Figure 1

To obtain satisfactory results, procedures specified in this service information letter must be accomplished in accordance with accepted methods and current government regulations. Diamond Aircraft Industries Inc. cannot be responsible for the quality of work performed in accomplishing the requirements of this service information letter. Diamond Aircraft reserves the right to void continued warranty coverage in the area affected by this service information letter if it is not incorporated. If you no longer own the aircraft to which this service information letter applies, please forward it to the current owner and send the name of the current owner to Diamond Aircraft Industries Inc. at the address below.

Diamond Aircraft Industries Inc. 1560 Crumlin Sideroad, London, Ontario, Canada N5V 1S2
Phone: (519) 457-4030 Ext. 3173 E-mail: techpubs@diamondair.com

COPYRIGHT 2010