OPTIONAL SERVICE BULLETIN NO. DAC1-27-05 REV. 0

I TECHNICAL DETAILS

I.1 Category

Optional.

I.2 Airplanes Affected

Type: DA20-C1

S/N: C0648 to C0772.

I.3 Date of Effectivity

05 March 2025

I.4 Time of Compliance

At owner's discretion.

I.5 Subject

Replacement of the flap actuator and installation of the flap resistor assembly.

ATA code: 27-50

I.6 Reason

This service bulletin addresses the replacement of the P/N 22-2750-10-00 flap actuator by P/N 22-2750-10-00_01 and the installation of flap resistor assembly due to the flap actuator motor obsolescence.

I.7 Concurrent Documents

None.

I.8 Approval

Engineering data referenced or contained in this service bulletin is approved as part of the type design.

I.9 Accomplishment/Instructions

1. Incorporate AMM-TR-MÄM-22-0016 into the Airplane Maintenance Manual or use an AMM revision in which AMM-TR-MÄM-22-0016 has been incorporated.
2. Remove the existing flap actuator. Refer to AMM Section 27-50.
3. Remove the bearing block from the existing flap actuator. Refer to Figure 2.
4. Remove the bolts, washers and self-locking nuts which attach the front mounting bracket. Refer to Figure 2.
5. Remove the existing front mounting bracket from the aircraft.
6. Make sure that the new front mounting bracket (item 1) will be installed on a flat surface of the composite.
7. Install the bolts (item 2), washers (items 3 and 4), and self-locking nuts (item 5) which attach the new front mounting bracket (item 1) to the aircraft. Refer to Figure 2.
8. Apply Aero Shell Grease 22 to the spacer and the bearing block. Refer to Figure 2.
9. Install the bearing block to the new flap actuator (item 8). Refer to Figure 2.
10. Put the spacer and the nylon washers (item 16) in the installation position. Refer to Figure 2.
11. Install the bolt (item 6), washers (item 7), and the self-locking nut (item 5) which attach the new flap actuator (item 8) to the new front mounting bracket (item 1). Refer to Figure 2.
12. At the aft control bulkhead, install the bolt (item 9), washers (items 10 and 7), and the self-locking nut (item 5) which attach the new flap actuator (item 8) to the flap bellcrank.

NOTE: A second person is required at this step to hold and position the flaps to have the rod end of the flap actuator line up with the bellcrank bracket.

13. Identify the attachment points to install the flap resistor assembly (item 15). Remove the bolts, washers, and self-locking nuts of the attachment points. Refer to Figure 1.

NOTE: The attachment points of the flap resistor assembly attach two existing relays (Figure 1). If MOD 0037 Pitot Heat is installed, the upper attachment point attaches the pitot heat relay (Figure 2).

14. Install the bolts (item 11), washers (item 12), bushings (item 14) and self-locking nuts (item 13) which attach the flap resistor assembly (item 15), and the two relays (three relays if MOD 0037 Pitot Heat installed). Refer to Figures 1 and 2.

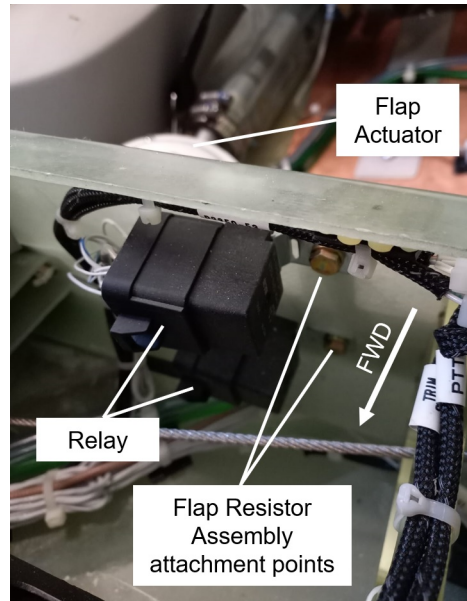

Figure 1. Flap resistor assembly attachment points (looking aft).

15. Connect the flap resistor assembly connectors to the flap motor connector and the flap control board connector. Refer to AMM Section 92-10.
16. Do the flap system adjustment test procedure. Refer to AMM Section 27-50.
17. Install the flap actuator cover. Refer to Figure 2.
18. Install the left pilot's seat. Refer to AMM Section 25-10.
19. Install the access panels below the aft control bulkhead. Refer to AMM Section 27-50.
21. Make all necessary entries in the logbooks.
21. Submit the Execution Report through the Diamond Partner Portal at:
<https://partners.diamondaircraft.com/>

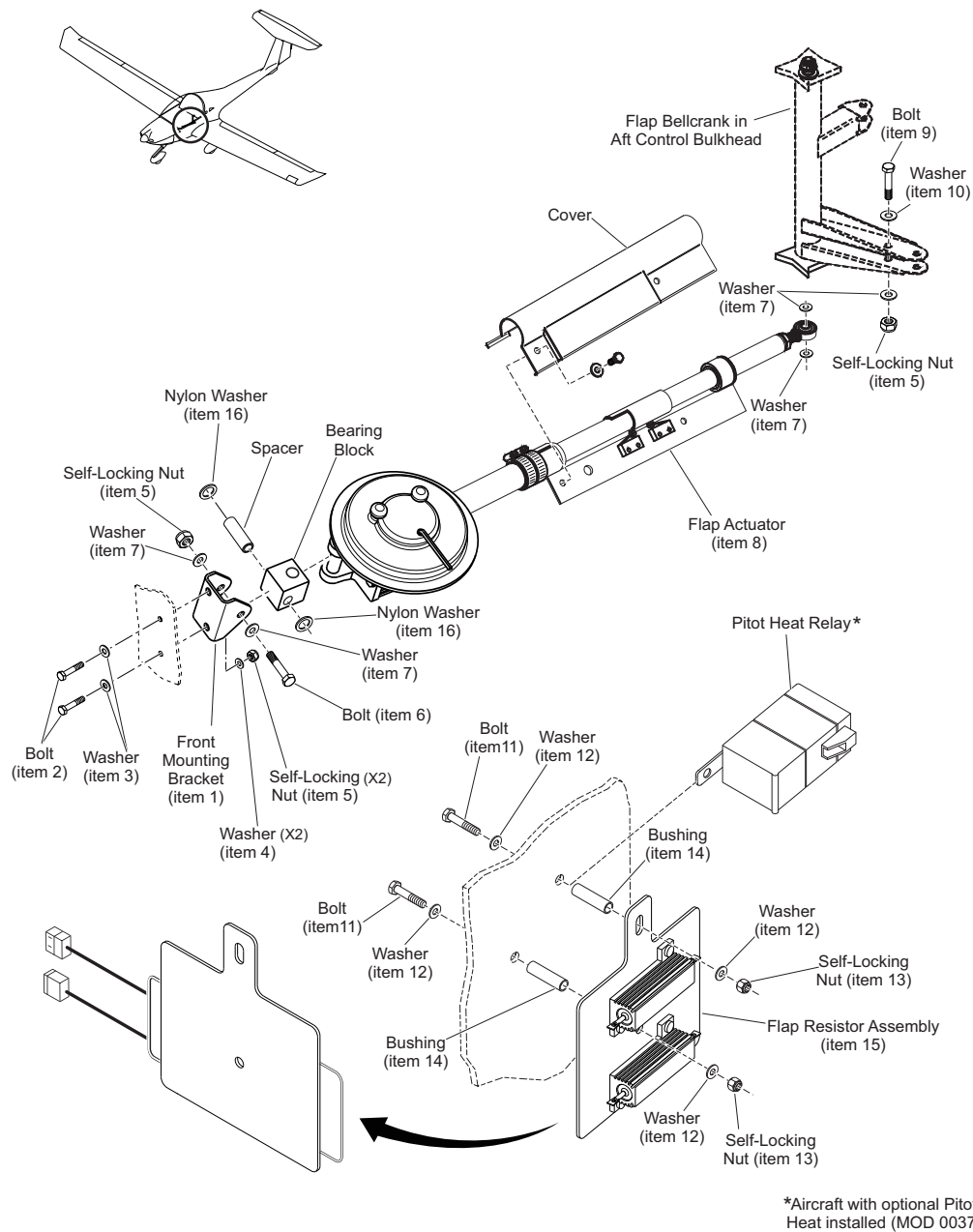

Figure 2. Flap actuator and flap resistor assembly installation

I.10 Mass (Weight) and CG

Make the following changes to the weight and balance:

Items Removed	Weight (kg)	Arm (m)
P/N 22-2750-10-00 Flap actuator	1.81	0.248

Items Added	Weight (kg)	Arm (m)
Flap actuator	1.95	0.248
Flap resistor assembly	0.25	0.179

II PLANNING INFORMATION

II.1 Material and Availability

Item	Quantity	Part Number	Description
1	1	22-2750-00-01	Front mounting bracket
2	2	AN4-7A	Bolt
3	2	MS16212-11	Washer
4	2	NAS 1149F0463P	Washer
5	4	MS21044N4	Self-locking nut
6	1	AN4-16A	Bolt
7	5	AN960-416	Washer
8	1	22-2750-10-00_01	Flap actuator
9	1	AN4-11A	Bolt
10	1	AN960-416L	Washer
11	2	AN3-10A	Bolt
12	4	AN960-10	Washer
13	2	MS21044N3	Self-locking nut
14	2	94639A550	Bushing
15	1	22-2750-11-00	Flap resistor assembly
16	2	NAS 1515H6L	Nylon washer

Diamond Aircraft Industries
OPTIONAL SERVICE BULLETIN
Model DA20-C1



The following consumable is required.

Quantity	Part Number	Description
As required	Aero Shell Grease 22	Synthetic grease

II.2 Special Tools

None.

II.3 Labour Effort

Approximately 8 hours will be required to accomplish this service bulletin.

This estimate is for direct labour performed by a technician, and it does not include setup, planning, familiarization, cure time, part fabrication, or tool acquisition.

II.4 Credit

None.

II.5 Reference Documents

DA20-C1 Aircraft Maintenance Manual (AMM), Document # DA201-C1.

III REMARKS

1. All work must be done by a certified aircraft service station or a certified aircraft maintenance mechanic.
2. All work, particular that, which is not especially described in this service bulletin, must be done in accordance with the referenced maintenance manual.
3. Completion of all work must be recorded in the logbook.
4. In case of doubt, contact Diamond Aircraft Industries.

To obtain satisfactory results, procedures specified in this service bulletin must be accomplished in accordance with accepted methods and current government regulations. Diamond Aircraft cannot be responsible for the quality of work performed in accomplishing the requirements of this service bulletin. Diamond Aircraft reserves the right to void continued warranty coverage in the area affected by this service bulletin if it is not incorporated.

If you no longer own the aircraft to which this service bulletin applies, please forward it to the current owner and send the name of the current owner to Diamond Aircraft at the address below.

Diamond Aircraft Industries Inc.
1560 Crumlin Sideroad, London, Ontario, Canada
N5V 1S2

Customer Support:
Phone: (519) 457-4041
Portal: partners.diamondaircraft.com



**EXECUTION REPORT TO
SERVICE BULLETIN
DAC1-27-05 REV. 0**

AIRPLANE INFORMATION

Airplane Serial Number _____
Airplane Registration _____
Airplane Operator _____
Hours of Operation of Airplane _____
No. of Landings _____
Hours of Operation of Engine _____
Typical Operation of Airplane _____
(private, club, training, other)

Name

Signature

Date

Please submit the Execution Report through the Diamond Partner Portal at
<https://partners.diamondaircraft.com/>