

SERVICE INFORMATION LETTER



Page: 1 of 2
09 Mar 11

SERVICE INFORMATION LETTER NO. SIL20A1-007

NOTE: Service Information Letters are used only:

1. To distribute information from Diamond Aircraft Industries (DAI) to our customers.
2. To distribute applicable information/documents from our suppliers to our customers with additional information.

NOTE: Typically there is no revision service for Service Information Letter (SIL). Each new information or change will be sent along with a new SIL.

1. TECHNICAL DETAILS

1.1 Aircraft Affected

ALL DA20-A1 aircraft equipped with ROTAX 912 series engine.

1.2 Subject

Replacement of oil dipstick.

1.3 Reason

It has been discovered, in some cases, that the new characteristics of some modern oils may result in a slower return of oil from the crankcase to the tank under certain conditions. This could possibly cause the oil tank level to fall to a level below the minimum. In order to help prevent this problem it is necessary to raise the minimum oil level in the tank. This is achieved by using a new dipstick with new level marks.

1.4 Information

For detailed technical information refer to the attached ROTAX Service Bulletin, Introduction of a New Oil Dipstick for ROTAX Engine Type 912 and 914 (Series), SB-912-040 R1, SB-914-026 R1 that is applicable without any further additions or restrictions.

2. OTHERS

Contact DAI or your local authorized Diamond Service Center.

To obtain satisfactory results, procedures specified in this service information letter must be accomplished in accordance with accepted methods and current government regulations. Diamond Aircraft Industries Inc. cannot be responsible for the quality of work performed in accomplishing the requirements of this service information letter. Diamond Aircraft reserves the right to void continued warranty coverage in the area affected by this service information letter if it is not incorporated. If you no longer own the aircraft to which this service information letter applies, please forward it to the current owner and send the name of the current owner to Diamond Aircraft Industries Inc. at the address below.

Diamond Aircraft Industries Inc. 1560 Crumlin Sideroad, London, Ontario, Canada N5V 1S2
Phone: (519) 457-4030 Ext. 3173 E-mail: techpubs@diamondair.com

SERVICE INFORMATION LETTER



Page: 2 of 2
09 Mar 11

Intentionally Left Blank



SERVICE BULLETIN

INTRODUCTION OF A NEW OIL DIPSTICK FOR ROTAX® ENGINE TYPE 912 AND 914 (SERIES)

SB-912-040 R1

SB-914-026 R1

MANDATORY

Repeating symbols:

Please, pay attention to the following symbols throughout this document emphasizing particular information.

▲ **WARNING:** Identifies an instruction, which if not followed, may cause serious injury or even death.

■ **CAUTION:** Denotes an instruction, which if not followed, may severely damage the engine or could lead to suspension of warranty.

◆ **NOTE:** Information useful for better handling.

1) Planning information

1.1) Engines affected

All versions of the engine type:

- 912 A to S/N 4,410.606
- 912 F to S/N 4,412.858
- 912 S to S/N 4,922.971
- 914 F to S/N 4,420.394

1.2) Concurrent ASB/SB/SI and SL

Further to this Service Bulletin the following additional Service Instructions must be observed and complied with:

- SI-04-1997 Venting of lubrication system, current issue.
- SI-18-1997 Selection of motor oil and general operating tips, current issue.
- SI-27-1997 Oil level check, current issue.
- SI-912-010 Oil change, current issue.
- SI-914-011 Oil change, current issue.

1.3) Reason

It has been discovered, in some cases, that the new characteristics of some modern oils can result in a slower return of oil from the crankcase to the tank under certain conditions. This could possibly cause the oil tank level to fall to a level below the minimum. In order to help prevent this problem it is necessary to raise the minimum oil level in the tank. This is achieved by using a new dipstick with new level marks.

1.4) Subject

Introduction of a new oil dipstick for ROTAX® engine type 912 (Series) and 914 (Series).

1.5) Compliance

At the next oil change or within the next 100 hours of operation, but at the latest by July 1st 2003, the replacement of the oil dipstick must be conducted.

1.6) Approval

The technical content of this document is approved under the authority of MOT, DOA Nr. MOT. JA. 03.

1.7) Manpower

Estimated man-hours:

Engine installed in the aircraft - - - manpower time will depend on installation and thus, no estimate is available from the engine manufacturer.

003120

AUGUST 2003

SB-912-040R1

SB-914-026R1

page 1 of 4

1.8) Mass data

change of weight - - - difference +0,4 kg (0.88 lb) for the airframe
moment of inertia - - - affected depending upon the position of the oil tank in the airframe .

1.9) Electrical load data

no change

1.10) Software accomplishment summary

no change

1.11) References

In addition to this technical information refer to current issue of

- All relevant Service Instructions (SI)
- Maintenance Manual (MM)

1.12) Other publications affected

The following amendments will become effective with this Service Bulletin. The replacement pages have to be incorporated without delay into the respective documentation of the aircraft manufacturer:

Bezeichnung	TNr.	Ausg.	Datum	Rev.	Kapitel	Seite
Operators Manual 912 Series	899370	0	1998 07 01	2		
Operators Manual 914 Series	899641	0	1998 12 01	2		
Maintenance Manual 912 Series	899372	0	1998 09 01	2		
Maintenance Manual 914 F	897812	0	1997 02 01	5		

1.13) Interchangeability of parts

- All old parts are stopped from further use and must be returned F.O.B. to a ROTAX[®] Authorized Distributor or their Service Centers.
- Further sale, use or shipment of all old style oil dipstick part no. 956150 in inventory are prohibited and must these put be returned F.O.B. to a ROTAX[®] Authorized Distributor or their Service Centers.
- All stored oil tanks must have the oil dipstick replaced by a new style dipstick.

2) Material Information

2.1) Material - cost and availability

Price and availability will be supplied on request by ROTAX[®] Authorized Distributors or their Service Centers.

2.2) Company support information

- The damages or costs incurred, namely with respect to shipping costs, down time, loss of income, telephone costs or costs of conversion to other engine versions or additional work, including simultaneous overhaul, are not covered and will not be borne or reimbursed by ROTAX[®].

2.3) Material requirement per engine

Parts requirement:

In compliance with this Service Bulletin the following parts are required.

Fig.no.	New p/n	Qty/engine	Description	Old p/n	Application
(1)	956151	1	oil dipstick	956150	oil tank

2.4) Material requirement per spare part

None

2.5) Rework of parts

None

2.6) Special tooling/lubricant-/adhesives-/sealing compound -Price and availability

None

3) Accomplishment / Instructions

Accomplishment

All the measures must be taken and confirmed by the following persons or facilities:

- ROTAX[®]-Airworthiness representative
- ROTAX[®]-Distributors or their Service Centers
- Persons approved by the respective Aviation Authority

▲ **WARNING:** Proceed with this work only in a non-smoking area and away from sparks or open flames. Switch off ignition and secure engine against unintentional operation. Secure aircraft against unauthorized operation. Disconnect negative terminal of aircraft battery.

▲ **WARNING:** Risk of scalds and burns! Allow engine to cool sufficiently and use appropriate safety gear while performing work.

▲ **WARNING:** Should removal of a locking device (namely lock tabs, self-locking fasteners) be required when undergoing disassembly/assembly, always replace with a new one.

◆ **NOTE:** All work has to be performed in accordance with the relevant Maintenance Manual.

3.1) Instructions

3.1.1) Replace of the oil dipstick

- Remove the oil dipstick part no. 956150 and replace by new oil dipstick part no. 956151.
- Inspect the oil level to be performed SI-27-1997 "Oil level check", current issue.
- Add oil if necessary.

◆ **NOTE:** By changing the oil dipstick, the minimum oil level is raised by approx. 40 mm (1.57 in.) and the height between the "min." and "max." level is reduced to 30 mm (1.18 in.) (approx. 0,45 litre).

- Restore aircraft to original operating configuration.
- Connect negative terminal of aircraft battery.

3.2) Testrun

Conduct test run including ignition and oil/coolant leak checks.

3.3) Summary

These instructions (section 3) have to be conducted in compliance with section 1.5.

◆ **NOTE:** The executed work are to be certified in the engine log book.

Approval of translation to best knowledge and judgment - in any case the original text in the German language and the metric units (SI-system) are authoritative.

4) Appendix

the following drawings should provide additional information:

oil dipstick, old version

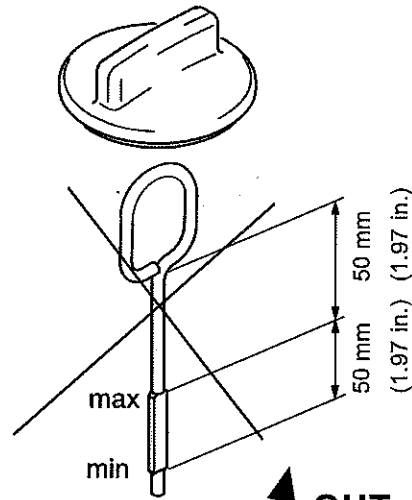

oil dipstick, new version

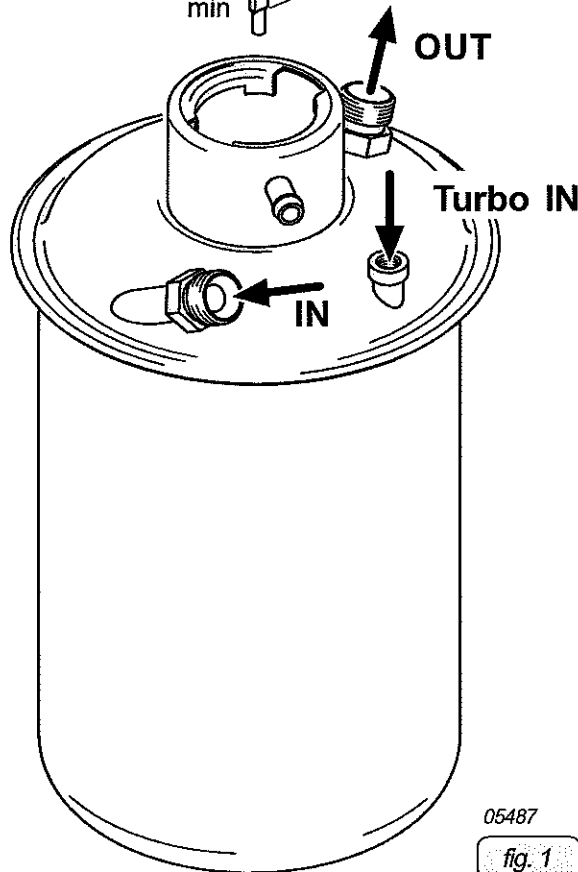
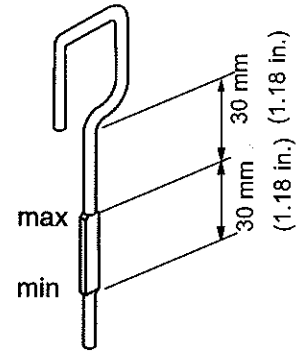

◆ NOTE:

The illustrations in this document show the typical construction. They may not represent full detail or the exact shape of the parts which have the same or similar function.

Exploded views are **not technical** drawings and are for reference only. For specific detail, refer to the current documents of the respective engine type.