

# SERVICE INFORMATION LETTER



Page: 1 of 2  
19 Oct 10

## **SERVICE INFORMATION LETTER NO. SIL20A1-006**

NOTE: Service Information Letters are used only:

1. To distribute information from Diamond Aircraft Industries (DAI) to our customers.
2. To distribute applicable information/documents from our suppliers to our customers with additional information.

NOTE: Typically there is no revision service for Service Information Letter (SIL). Each new information or change will be sent along with a new SIL.

### **1. TECHNICAL DETAILS**

#### 1.1 Aircraft Affected

ALL DA20-A1 aircraft.

#### 1.2 Subject

Federal Aviation Administration (FAA) Airworthiness Directive (AD) "2010-20-23 Bombardier-Rotax GmbH (formerly Rotax, Motorenfabrik): Amendment 39-16458. Docket No. FAA-2010-0342; Directorate Identifier 2002-NE-08-AD" for inspection of engine crankcase for cracks especially in the area of cylinder 1 upper side, between cylinder 1 and 3 upper side, cylinder 4 lower-right side and detailed inspection in the area identified in Figure 2 of this AD (attached).

#### 1.3 Reason

FAA has issued this AD to prevent oil loss caused by cracks in the engine crankcase of Bombardier-Rotax GmbH type 912 F series, 912 S series, and 914 F series reciprocating engines, which could lead to in-flight failure of the engine and forced landing.

#### 1.4 Information

For detailed technical information refer to the attached FAA Airworthiness Directive that is applicable without any further additions or restrictions.

### **2. OTHERS**

Contact DAI or your local authorized Diamond Service Center.

To obtain satisfactory results, procedures specified in this service information letter must be accomplished in accordance with accepted methods and current government regulations. Diamond Aircraft Industries Inc. cannot be responsible for the quality of work performed in accomplishing the requirements of this service information letter. Diamond Aircraft reserves the right to void continued warranty coverage in the area affected by this service information letter if it is not incorporated. If you no longer own the aircraft to which this service information letter applies, please forward it to the current owner and send the name of the current owner to Diamond Aircraft Industries Inc. at the address below.

Diamond Aircraft Industries Inc. 1560 Crumlin Sideroad, London, Ontario, Canada N5V 1S2  
Phone: (519) 457-4030 Ext. 3173 E-mail: techpubs@diamondair.com

# SERVICE INFORMATION LETTER



Page: 2 of 2  
19 Oct 10

Intentionally Left Blank

[Federal Register: October 4, 2010 (Volume 75, Number 191)]  
[Rules and Regulations]  
[Page 61046-61050]  
From the Federal Register Online via GPO Access [wais.access.gpo.gov]  
[DOCID:fr04oc10-2]

---

## **DEPARTMENT OF TRANSPORTATION**

### **Federal Aviation Administration**

#### **14 CFR Part 39**

**[Docket No. FAA-2010-0342; Directorate Identifier 2002-NE-08-AD; Amendment 39-16458; AD 2010-20-23]**

**RIN 2120-AA64**

#### **Airworthiness Directives; Bombardier-Rotax GmbH Type 912 F, 912 S, and 914 F Series Reciprocating Engines**

**AGENCY:** Federal Aviation Administration (FAA), Department of Transportation (DOT).

**ACTION:** Final rule.

---

**SUMMARY:** The FAA is superseding an existing airworthiness directive (AD) for certain serial numbers (S/Ns) of Bombardier-Rotax GmbH type 912 F and 914 F series reciprocating engines. That AD currently requires initial and repetitive visual inspections of the engine crankcase for cracks. This AD requires those same inspections, adds the 912 S series to the affected population, adds a test procedure to determine the engine suitability for a special flight permit, and changes applicability from engine S/N to crankcase S/N. This AD results from an increase in the affected crankcase population. We are issuing this AD to prevent oil loss caused by cracks in the engine crankcase, which could lead to in-flight failure of the engine and forced landing.

**DATES:** This AD becomes effective November 8, 2010.

**ADDRESSES:** You can get the service information identified in this AD from BRP-Rotax GmbH & Co. KG, Welser Strasse 32, A-4623 Gunskirchen, Austria.

The Docket Operations office is located at Docket Management Facility, U.S. Department of Transportation, 1200 New Jersey Avenue, SE., West Building Ground Floor, Room W12-140, Washington, DC 20590-0001.

**FOR FURTHER INFORMATION CONTACT:** Alan Strom, Aerospace Engineer, Engine Certification Office, FAA, Engine & Propeller Directorate, 12 New England Executive Park, Burlington, MA 01803; e-mail: alan.strom@faa.gov; telephone (781) 238-7143; fax (781) 238-7199.

**SUPPLEMENTARY INFORMATION:** The FAA proposed to amend 14 CFR part 39 by superseding AD 2002-16-26, Amendment 39-12865 (67 FR 53296, August 15, 2002), with a proposed AD. The proposed AD applies to Bombardier-Rotax GmbH type 912 F, 912 S, and 914 F

series reciprocating engines with certain serial-numbered crankcases. We published the proposed AD in the Federal Register on April 7, 2010 (75 FR 17632). That action proposed to require initial visual inspection for cracks in the engine crankcase of engines with certain serial-numbered crankcases, within 50 hours time-in-service (TIS) after the effective date of that AD, and repetitive visual inspections at each 100-hour, annual, or progressive inspection, or within 110 hours TIS since last inspection, whichever occurs first. If any cracks are found, the engine must be removed from service.

### **Examining the AD Docket**

You may examine the AD docket on the Internet at <http://www.regulations.gov>; or in person at the Docket Operations office between 9 a.m. and 5 p.m., Monday through Friday, except Federal holidays. The AD docket contains this AD, the regulatory evaluation, any comments received, and other information. The street address for the Docket Operations office (telephone (800) 647-5527) is provided in the ADDRESSES section. Comments will be available in the AD docket shortly after receipt.

### **Comments**

We provided the public the opportunity to participate in the development of this AD. We have considered the comment received.

One commenter asks us to change paragraph (g)(4) from "If the engine crankcase is cracked, replace the engine before further flight" to "If the engine crankcase is cracked, replace, repair, or overhaul the engine before further flight". The commenter states that this would allow the option of replacing the crankcase as a repair or overhaul as well as an outright engine replacement.

We partially agree. An owner or operator might interpret paragraph (g)(4) to mean they can't repair the engine. We have changed paragraph (g)(4) to state "If the engine crankcase is cracked, remove the engine from service before further flight."

### **Conclusion**

We have carefully reviewed the available data, including the comment received, and determined that air safety and the public interest require adopting the AD with the change described previously. We have determined that this change will neither increase the economic burden on any operator nor increase the scope of the AD.

### **Costs of Compliance**

Based on the service information, we estimate that this AD will affect about 250 products of U.S. registry. We also estimate that it will take about 3 work-hours per inspection and 20 work hours to replace the crankcase to comply with this AD. The average labor rate is \$85 per work-hour. Required parts will cost about \$6,500 per crankcase. Based on these figures and an estimate of one crankcase replaced per year, we estimate the annual cost of the AD on U.S. operators to be \$71,950. Our cost estimate is exclusive of possible warranty coverage.

### **Authority for This Rulemaking**

Title 49 of the United States Code specifies the FAA's authority to issue rules on aviation safety. Subtitle I, section 106, describes the authority of the FAA Administrator. Subtitle VII, Aviation Programs, describes in more detail the scope of the Agency's authority.

We are issuing this rulemaking under the authority described in Subtitle VII, part A, subpart III, section 44701, "General requirements." Under that section, Congress charges the FAA with promoting safe flight of civil aircraft in air commerce by prescribing regulations for practices,

methods, and procedures the Administrator finds necessary for safety in air commerce. This regulation is within the scope of that authority because it addresses an unsafe condition that is likely to exist or develop on products identified in this rulemaking action.

## **Regulatory Findings**

We have determined that this AD will not have federalism implications under Executive Order 13132. This AD will not have a substantial direct effect on the States, on the relationship between the national government and the States, or on the distribution of power and responsibilities among the various levels of government.

For the reasons discussed above, I certify that this AD:

- (1) Is not a "significant regulatory action" under Executive Order 12866;
- (2) Is not a "significant rule" under DOT Regulatory Policies and Procedures (44 FR 11034, February 26, 1979); and
- (3) Will not have a significant economic impact, positive or negative, on a substantial number of small entities under the criteria of the Regulatory Flexibility Act.

We prepared a summary of the costs to comply with this AD and placed it in the AD Docket. You may get a copy of this summary at the address listed under ADDRESSES.

## **List of Subjects in 14 CFR Part 39**

Air transportation, Aircraft, Aviation safety, Safety.

## **Adoption of the Amendment**

Accordingly, under the authority delegated to me by the Administrator, the Federal Aviation Administration amends 14 CFR part 39 as follows:

### **PART 39—AIRWORTHINESS DIRECTIVES**

1. The authority citation for part 39 continues to read as follows:

Authority: 49 U.S.C. 106(g), 40113, 44701.

#### **§ 39.13 [Amended]**

2. The FAA amends § 39.13 by removing Amendment 39-12865 (67 FR 53296, August 15, 2002), and by adding a new airworthiness directive, Amendment 39-16458, to read as follows:



---

**2010-20-23 Bombardier-Rotax GmbH (formerly Rotax, Motorenfabrik):** Amendment 39-16458.  
Docket No. FAA-2010-0342; Directorate Identifier 2002-NE-08-AD.

**Effective Date**

- (a) This airworthiness directive (AD) becomes effective November 8, 2010.

**Affected ADs**

- (b) This AD supersedes AD 2002-16-26, Amendment 39-12865.

**Applicability**

(c) This AD is applicable to Bombardier-Rotax GmbH type 912 F series, 912 S series, and 914 F series reciprocating engines that have a crankcase serial-numbered 27811 or lower, installed. These engines are installed on, but not limited to, Aeromot-Industria Mecanico Metalurgica Itda AMT-300; Aquila Technische Entwiklugen GmbH AQUILA AT01; Diamond Aircraft Industries DA-20A1; Diamond Aircraft Industries GmbH Models HK36TC, HK36TTC, HK36TTC-ECO, and HK36TTS; Iniziative Industriali Italiane S.p.A. Sky Arrow 650 series; SCHEIBE-Flugzeugbau GmbH SF 25C; and Stemme S10-VT aircraft.

**Unsafe Condition**

(d) This AD results from an increase in the affected engine crankcase population. We are issuing this AD to prevent oil loss caused by cracks in the engine crankcase, which could lead to in-flight failure of the engine and forced landing.

**Compliance**

(e) You are responsible for having the actions required by this AD performed within the compliance times specified, unless the actions have already been done.

**Determining the Crankcase Serial Number (S/N)**

(f) Determine if your crankcase is affected by looking at the S/N in the area indicated by XXX, following "Made in Austria," as shown on Figure 2 of this AD. The marking is on both crankcase halves.

**Initial Inspection**

(g) Within 50 hours time-in-service (TIS) from the effective date of this AD, perform a visual inspection as follows:

- (1) Inspect the engine crankcase (item 1, Figure 1 of this AD) for cracks especially in the area of cylinder 1 upper side (item 2), between cylinder 1 and 3 upper side (item 3), cylinder 4 lower-right side (item 4) and detailed inspection in the area identified in Figure 2 (item 5) of this AD.

Information concerning this inspection can be found in Bombardier-Rotax Mandatory Service Bulletins No. SB-912-029, Revision 3, dated July 11, 2006 and No. SB-914-018, Revision 3, dated July 11, 2006.

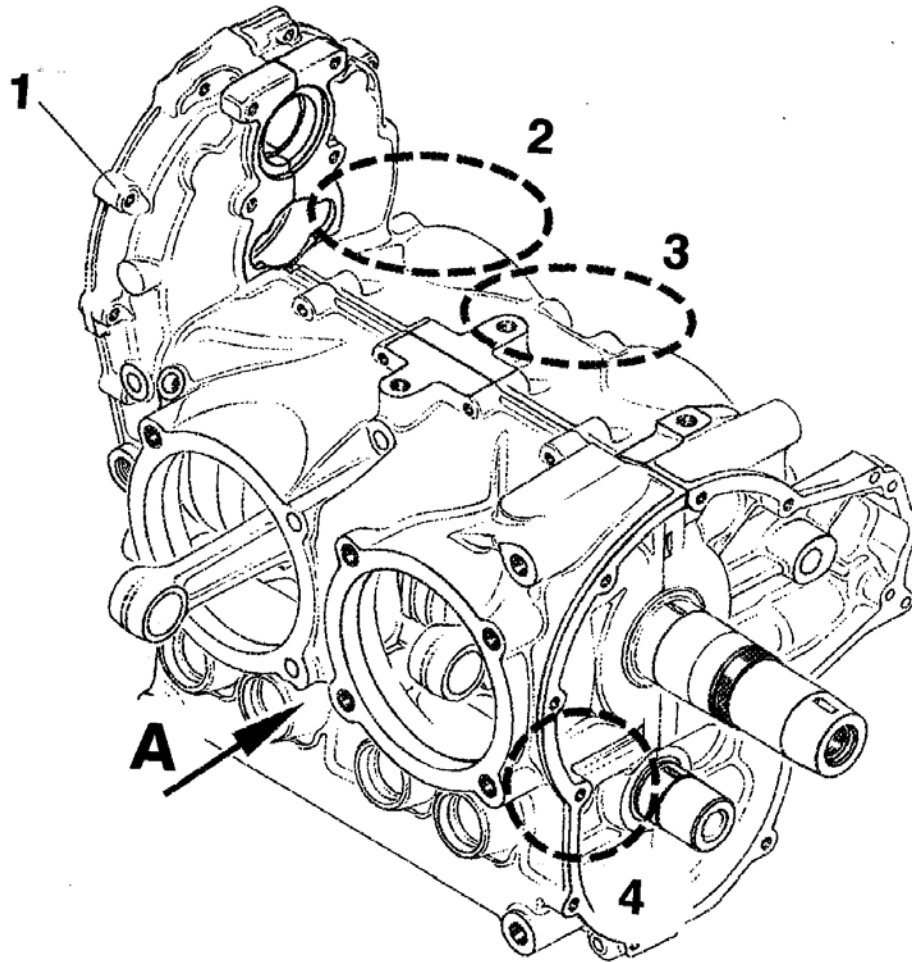

**LEGEND**

- 1. Engine Crankcase
- 2. Cylinder 1 Upper Side
- 3. Cylinder 3 Upper Side
- 4. Cylinder 4 Lower-right Side

**Figure 1. Engine Crankcase Inspection Areas**

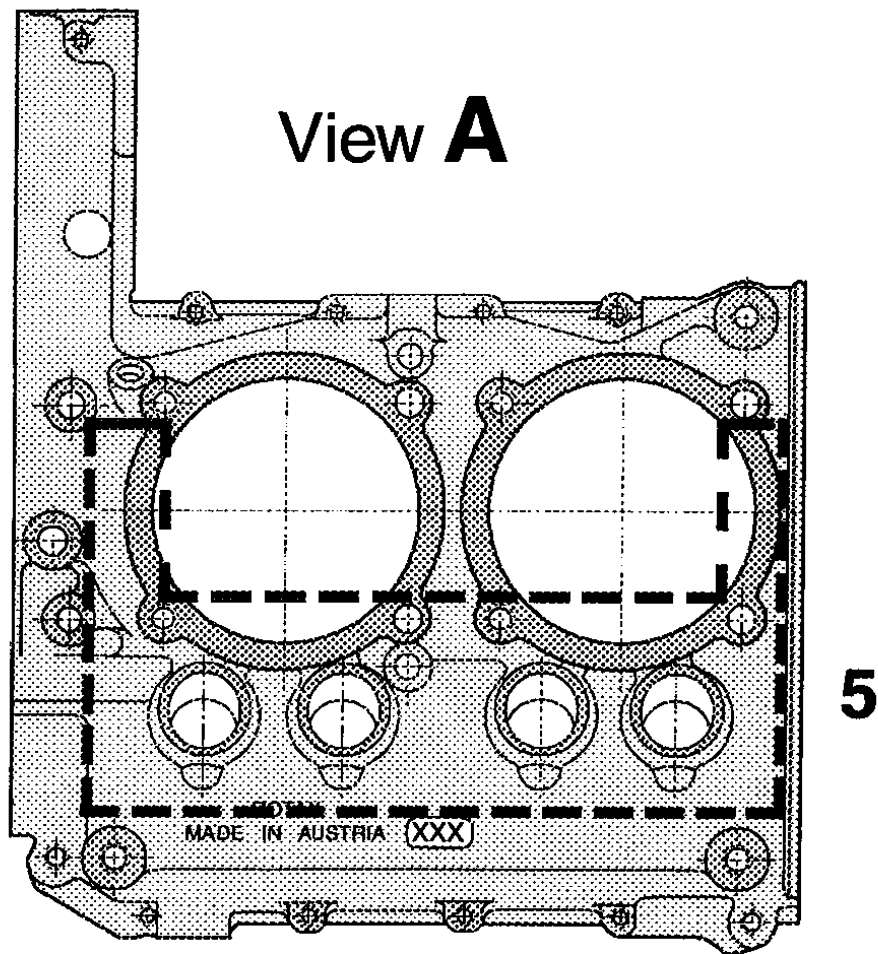

**Figure 2. Engine Crankcase Inspection Areas – View A**

(2) Cracks in crankcases of engines with a ROTAX cooling air baffle may not be easily visible, and oil leaks may be an indication of cracks. Visually inspect for oil leaks in areas of cylinder 1 upper side (item 2, Figure 1 of this AD) and between cylinder 1 and cylinder 3 upper side (item 3).

(3) If you find oil leaks, determine the source by either using a borescope or removing the object blocking the view such as the air baffle or accessory, and perform the inspection.

(4) If the engine crankcase is cracked, remove the engine from service before further flight.

### **Repetitive Inspections**

(h) Visually inspect the engine crankcase (item 1, Figure 1 of this AD) for cracks at each 100-hour, annual, or progressive inspection, or within 110 hours TIS since last inspection, whichever occurs first, in accordance with paragraphs (g)(1) through (g)(4) of this AD.

### **Alternative Methods of Compliance**

(i) The Manager, Engine Certification Office, has the authority to approve alternative methods of compliance for this AD if requested using the procedures found in 14 CFR 39.19.



## Special Flight Permits

(j) Under 14 CFR part 39.23, we are limiting the special flight permits for this AD by the following conditions if the crankcase is cracked or there is evidence of oil leakage from the crankcase:

(1) Perform a leak check as follows:

(i) Clean the crankcase surface to remove any oil.

(ii) Warm up the engine to a minimum oil temperature of 50 degrees C (120 degrees F).

Information about warming up the engine can be found in the applicable line maintenance manual.

(iii) Accelerate the engine to full throttle and stabilize at full throttle speed for a time period of 5 to 10 seconds. Information about performing a full throttle run can be found in the applicable line maintenance manual.

(iv) Shutdown after running the engine at idle only long enough to prevent vapor locks in the cooling system and fuel system.

(v) Inspect the crankcase for evidence of oil leakage. Oil wetting is permitted, but oil leakage of more than one drip in 3 minutes after engine shutdown is not allowed.

(2) Check the crankcase mean pressure to confirm that it is 1.46 pounds-per-square inch gage (psig) (0.1 bar) or higher when checked at takeoff power to ensure proper return of oil from the crankcase to the oil tank. Information about checking crankcase mean pressure is available in the Lubrication System section of the applicable engine installation manual.

(3) A ferry flight is not allowed if oil leakage exceeds one drip in 3 minutes or if crankcase mean pressure is below 1.46 psig.

## Optional Terminating Action

(k) Installing a crankcase that has a S/N above 27811 terminates the inspection requirements of paragraphs (g)(1) through (g)(4) and (h) of this AD.

## Related Information

(l) Contact Alan Strom, Aerospace Engineer, Engine Certification Office, FAA, Engine & Propeller Directorate, 12 New England Executive Park, Burlington, MA 01803; e-mail: alan.strom@faa.gov; telephone (781) 238-7143; fax (781) 238-7199, for more information about this AD.

(m) EASA airworthiness directive 2007-0025, dated February 1, 2007, also addresses the subject of this AD.

(n) Bombardier-Rotax Mandatory Service Bulletins No. SB-912-029, Revision 3, dated July 11, 2006 and No. SB-914-018, Revision 3, dated July 11, 2006, pertain to the subject of this AD. Contact BRP-Rotax GmbH & Co. KG, Welser Strasse 32, A-4623 Gunskirchen, Austria, or go to rotax-aircraft-engines.com for a copy of this service information.

## Material Incorporated by Reference

(o) None.

Issued in Burlington, Massachusetts, on September 24, 2010.  
Francis A. Favara,  
Manager, Engine and Propeller Directorate,  
Aircraft Certification Service.