

# SERVICE BULLETIN

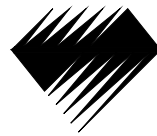

**Diamond**  
AIRCRAFT

Service Bulletin No.: DA20-73-03, Rev.2

Date Issued: April 13, 1998

Title: Automotive Fuel Conversion

Page: 1 of 7

1. ATA Code: 7310

## PLANNING INFORMATION:

2. Effectivity: DA20-A1 aircraft serial Number 10002 to 10092 equipped with ROTAX 912 A3 engines.

3. General: This service bulletin addresses the modifications required to enable ROTAX 912 A3 equipped DA20-A1 Katanas to operate with automotive fuel as specified in the aircraft flight manual.

4. Compliance: Optional.

5. Approval: Engineering data referenced or contained in this bulletin is approved as part of the type design.

6. Labor: Approximately 3.0 hours will be required to accomplish this service bulletin.

*This estimate is for direct labor performed by a technician and it does not include setup, planning, familiarization, cure time, part fabrication or tool acquisition.*

7. Material:	Part Number	Description	Qty
	996-594	Fuel Pump	1
	1181	Copper Shim	1"
	874-292	Fuel Line Assy	1
	840-511	Screw	1
	950-141	Gasket	7
	956-313	Nipple	1
	940-872	Banjo Bolt	1
	851-071	Support Bracket LH	1
	851-073	Support Bracket RH	1
	851-115	Clamp	2
	241-841	Screw	2
	842-030	Nut	4
	941-850	Fuel Line Connector	2
	A2704-4-6	Adapter	1
	FC3401B01B38D024	Hose (distribution block to firewall)	1
	1N	Spiral Wrap	225mm
Pre-assembled	{ 20-2810-00-01	Distribution Block	1
	{ 20-2800-08-00	Pressure Sender	1
	{ 941-785	Banjo Bolt, Pilot Jet Assy.	1
Pre-assembled as wire #73304A20	{ 36151	Ring Terminal	1
	{ 2-520184-2	Faston Terminal	1
	{ M22759/34-20-9	Wire	1050mm

# SERVICE BULLETIN

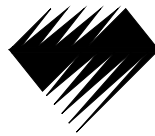

**Diamond**  
AIRCRAFT

Service Bulletin No.: DA20-73-03, Rev.2

Date Issued: April 13, 1998

Title: Automotive Fuel Conversion

Page: 2 of 7

## 7. Material: Continued

The above material is available by ordering material kit P/N DA20-73-03AMK2

Parts and materials may be required but not supplied in kit;

20-1120-00-17 Placard, Auto Fuel (English) 1

20-1120-01-16 Placard, Auto Fuel (German) 1

Procure locally. - Cable ties

**8. Special Tools:** An 11mm socket with a 14mm outside diameter is required.

**9. References:** DA20 Maintenance Manual Doc. # DA201.

DA20-A1 Flight Manual Doc # DA202, #DA202-VLA, #DA202D.

ROTAX 912 F Maintenance Manual.

## 10. Accomplishment Instructions:

**10.1** Disconnect the battery, negative lead first.

**10.2** Remove the instrument panel cover.

**10.3** Close the fuel shutoff valve.

### WARNING

Extinguish any source of heat or open flame before working on the fuel system.

**NOTE:** All work on the engine and its fuel system must be carried out in accordance with the ROTAX 912-F maintenance manual. Observe torque values given in the manual. Do not reuse self locking nuts on the engine or airframe.

The steps listed below (which refer to engine components) provide only an order and direction in which to complete the fuel system conversion. Where the fuel system configuration differs from the ROTAX 912-F maintenance manual additional instructions are given, Refer to figure 1,2 and 3

**10.4** Remove the upper and lower cowling. Identify the fuel supply and return line fittings. Remove the fuel lines from the carburetors, fuel pump, firewall fittings and fuel manifold. Cover the open fittings.

**10.5** Remove the four mounting screws securing the fuel distribution manifold and fuel line clamps to the firewall. Discard the clamps. Install the stainless steel screws and seal the screw holes in the firewall.

**10.6** Remove the fuel pump from the engine.

**10.7** Disconnect the throttle and choke cables from the carburetors.

**10.8** Disconnect the throttle and choke cables from the support bracket.

**10.9** Remove the support bracket from both carburetors.

**10.10** Install the new support brackets on the carburetors.

# SERVICE BULLETIN



Service Bulletin No.: DA20-73-03, Rev.2

Date Issued: April 13, 1998

Title: Automotive Fuel Conversion

Page: 3 of 7

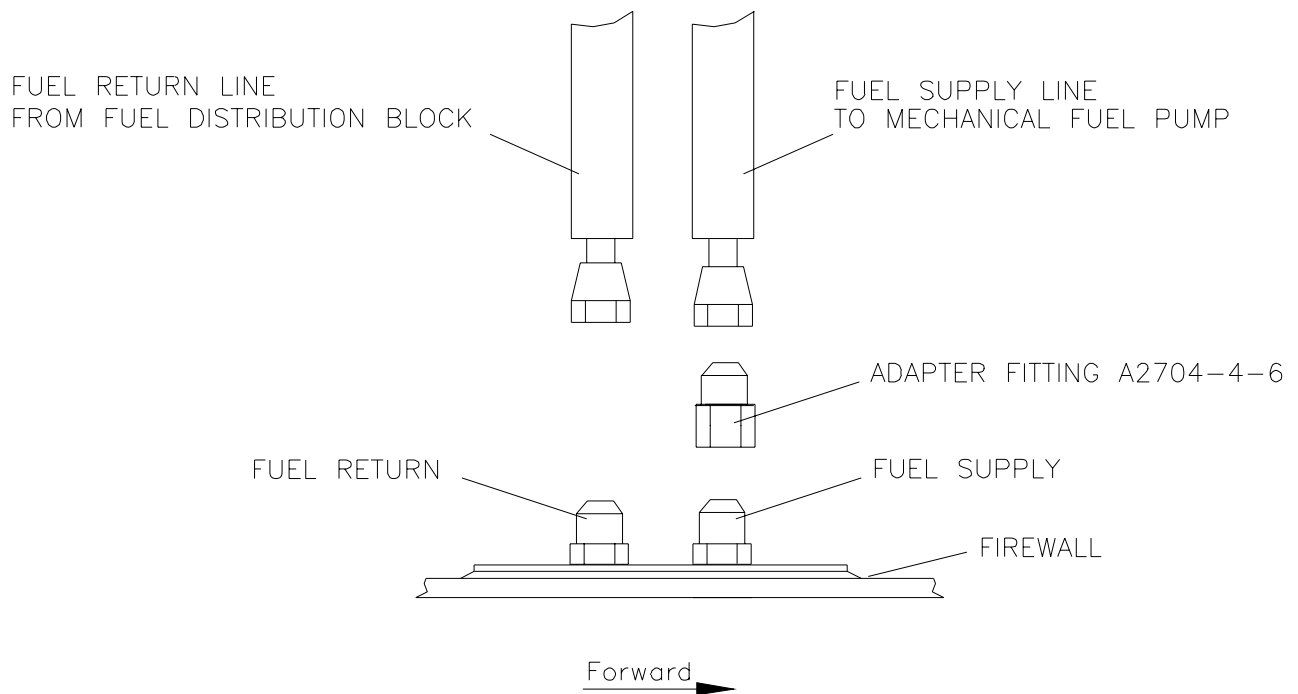
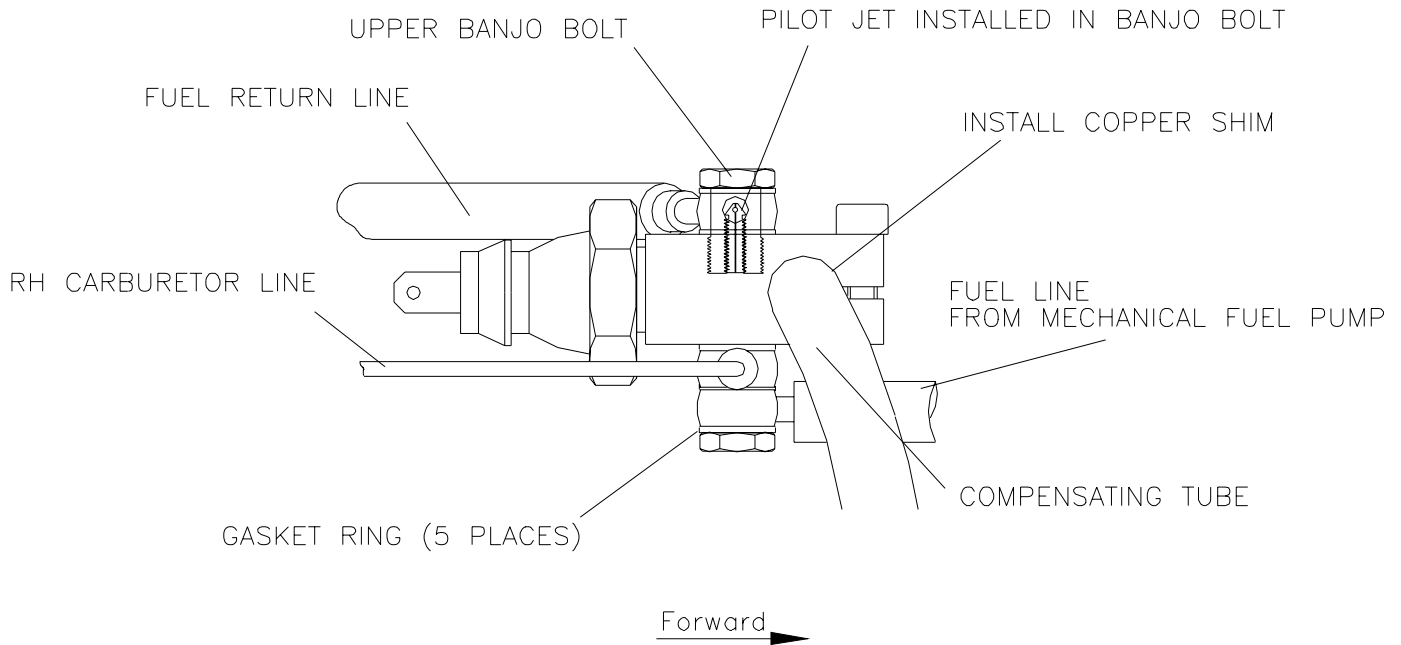
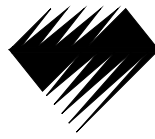

Figure 1

# SERVICE BULLETIN



**Diamond**  
AIRCRAFT

Service Bulletin No.: DA20-73-03, Rev.2

Date Issued: April 13, 1998

Title: Automotive Fuel Conversion

Page: 4 of 7

## 10. Accomplishment Instructions: Continued

- 10.11 Install the throttle and choke cables to the support bracket.
- 10.12 Connect the throttle and choke cables to the carburetors.
- 10.13 Install the new carburettor fuel line, clamps, connectors and gasket rings. Use the 11mm thin wall socket to install the connectors.
- 10.14 Install the new fuel pump.
- 10.15 Remove the clamp on the right side of the compensating tube. Pull the compensating tube from the rubber hose.
- NOTE:** The fuel pressure sender and distribution block have been supplied as one assembly. **DO NOT** disassemble.
- NOTE:** Maintain adequate clearance between the Fuel Sender and the Ignition modules.
- 10.16 Carefully slide the fuel distribution block over the compensating tube and position it so that it aligns with the ring nipples on the fuel lines. Install the copper shim around the compensating tube where the fuel distribution block is to be positioned. Apply Loctite 222 to the fuel distribution block mounting screw. Tighten the fuel distribution block screw so that the fuel distribution block is not able to move laterally along the compensating tube.
- 10.17 If the fuel line ring nipples do not align naturally with the fuel distribution block inlet, gently reshape the lines as required until they align properly and can be assembled to the fuel distribution block without introducing preload to the fuel lines.
- NOTE:** The upper banjo bolt has been fitted with a restricting orifice. **DO NOT** remove it.
- 10.18 Install the upper and lower banjo bolts, gasket rings and fuel return line to the distribution manifold, see figure 1.
- 10.19 Torque the gear box cap screw attaching the bracket to 90 in.lb (10 Nm)
- 10.20 Tie the fuel hoses as shown in figure 3.
- 10.21 Connect the fuel supply and return lines at the firewall fittings, see figure 1.
- 10.22 Remove the existing wire for the fuel pressure sender from the wire harness and disconnect it from the terminal block on the engine electrical shelf.

# SERVICE BULLETIN



Service Bulletin No.: DA20-73-03, Rev.2

Date Issued: April 13, 1998

Title: Automotive Fuel Conversion

Page: 5 of 7

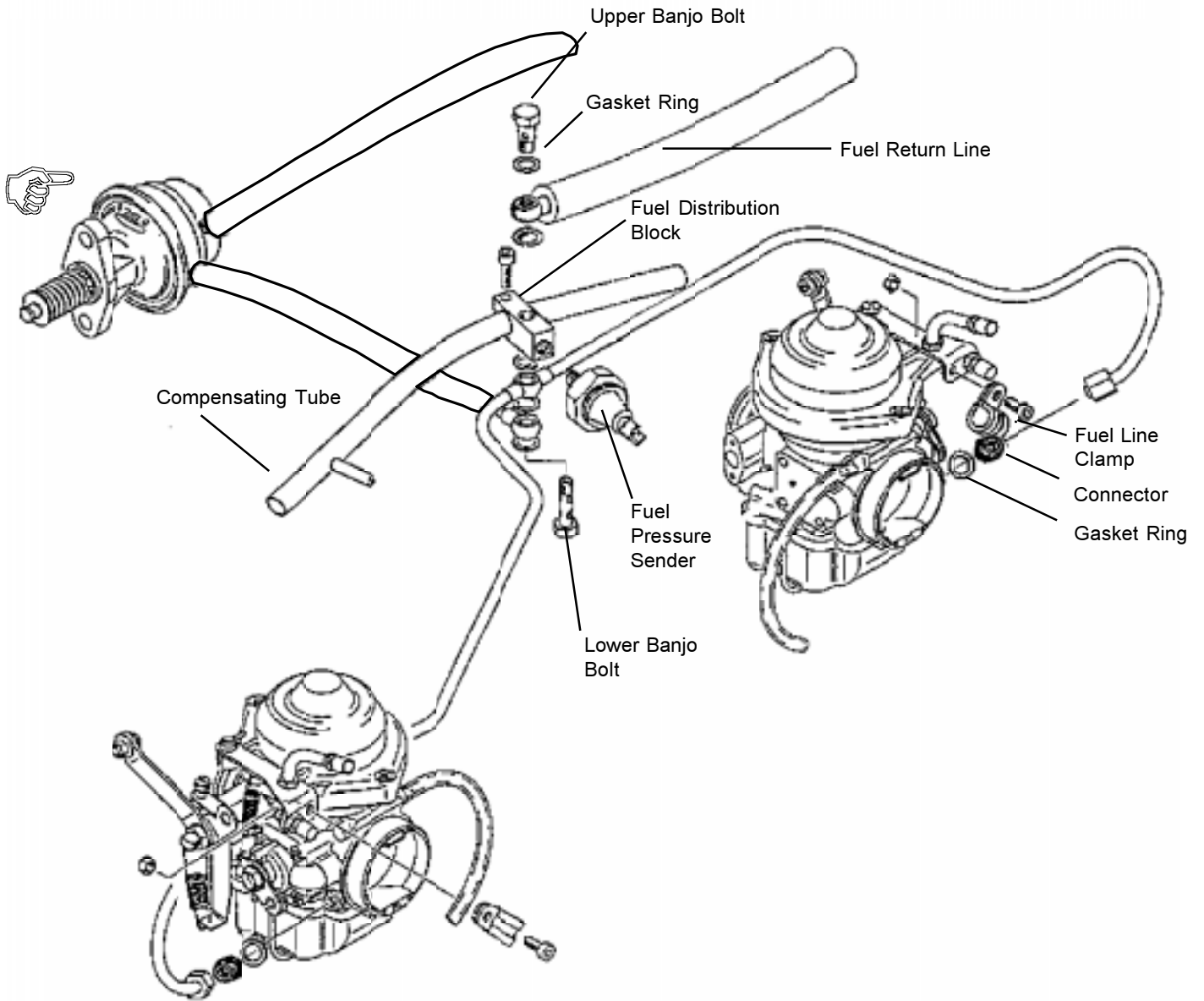

Figure 2

# SERVICE BULLETIN



Service Bulletin No.: DA20-73-03, Rev.2

Date Issued: April 13, 1998

Title: Automotive Fuel Conversion

Page: 6 of 7

## 10. Accomplishment Instructions: Continued

- 10.23 Connect the new wire to the terminal block and route it along with the existing wire harness to the new fuel pressure sender location. Replace any spiral wrap or cable ties removed to route the wire. Install the 1N spiral wrap on the end of the wire that connects to the fuel pressure sender to protect it from abrasion. Connect the wire to the fuel pressure sender.
- 10.24 Connect the battery leads (positive lead first). Open the fuel valve.
- 10.25 Run the electric fuel pump to check for fuel leaks around the Fuel Distribution Block and the engine driven pump. Check that the Fuel Pressure Warning light extinguishes after the fuel pump is turned on and illuminates shortly after the pump is turned off. With the pump running open the fuel cap and listen for fuel returning to the tank.
- 10.26 Run the engine and check for proper operation of the fuel system.
- 10.27 Check for fuel/oil leaks
- 10.28 Install the engine cowlings.
- 10.29 Remove the existing placard above the fuel filler, clean the area and install the new placard.
- 10.30 Make a log book entry stating that service bulletin DA20-73-03 Rev. 2 has been incorporated and amend the weight and balance record of the aircraft.

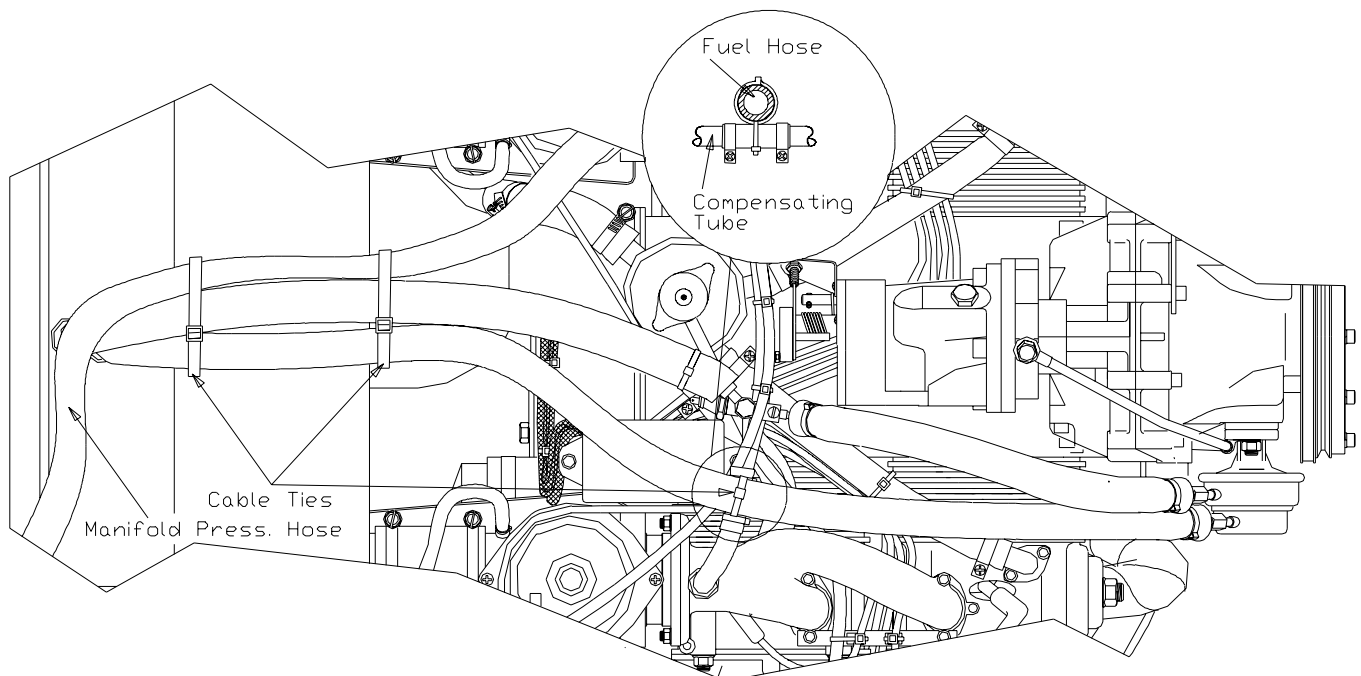
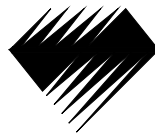

FIGURE 3

# SERVICE BULLETIN



**Diamond**  
AIRCRAFT

**Service Bulletin No.:** DA20-73-03, Rev.2

**Date Issued:** April 13, 1998

**Title:** Automotive Fuel Conversion

**Page:** 7 of 7

## **11. Weight and Balance:**

The weight decreases by 0.9 Lbs. (0.4 kg), -27" (-0.686m) from the reference datum.

## **12. Electrical Load Data:** Not Applicable.

## **13. Availability:** Contact Diamond Aircraft.

*To obtain satisfactory results, procedures specified in this service bulletin must be accomplished in accordance with accepted methods and current government regulations. Diamond Aircraft Industries Inc. cannot be responsible for the quality of work performed in accomplishing the requirements of this service bulletin. Diamond Aircraft reserves the right to void continued warranty coverage in the area affected by this Service Bulletin until the date the Service Bulletin is incorporated.*

*If you no longer own the aircraft to which this service bulletin applies, please forward it to the current owner and send the name of the current owner to Diamond Aircraft Industries, Inc., at the address below*

Diamond Aircraft Industries Inc. 1560 Crumlin Sideroad, London, Ontario, Canada N5V 1S2  
Phone: (519) 457-4041 Fax: (519) 457-4045