

# SERVICE BULLETIN



**Service Bulletin No.:** DA20-28-01 Rev 0  
**Title:** Fuel Cap, Safety Chain

**Date Issued:** August. 26, 1996  
**Page:** 1 of 3

**1. ATA Code:** 2800

## Planning Information:

**2. Effectivity:** All DA20 Katanas S/N 10001 to 10193 inclusive.

**3. General:** The existing Fuel Filler Cap (P/N UD-3F) requires frequent lubrication of the O-ring seal, under high usage conditions. Failure to lubricate the seal may cause loss of fuel cap security. This bulletin describes the installation of a fuel cap safety chain.

**4. Compliance:** Compliance with this Service Bulletin is recommended upon receipt of materials.

**5. Approval:** Engineering data referenced or contained in this Bulletin is approved as part of the type design.

**6. Labour:** Approximately 1.0 Man-hour will be required to accomplish this modification.

## 7. Material:

Qty:	Description:	Part Number:
1	Chain Assembly, Retaining, Fuel Cap	20-2800-12-00
1	Washer, flat	#4 AN960
1	Rivet, 100° C'sink	CCR244SS-4-03
1	Nut, Self Lock, Low Height (Optional, see 10.3.5)	MS 21083-N6 or AN 364-624

The above materials may be ordered as kit DA20-28-01MK.  
Contact Diamond Aircraft for price and availability.

1	Fuel Sealant	PR-1435 or PR1422B (or equivalent, obtain locally)
---	--------------	---

**8. Special Tools:** 1/8" drill or # 30 drill  
100 degree counter sink tool  
Rivet gun

**9. References:** DA20 Katana Maintenance Manual, DA201  
AC 43.13 1A/2A Aircraft Inspection, Repair & Alterations

## 10. Accomplishment Instructions:

### 10.1 Filler Neck Removal. (20-2800-07-00 / 20-2810-07-00)

- 10.1.1 Remove baggage floor.
- 10.1.2 Remove filler hose or as per Maintenance Manual Chapter 28-10. Carefully seal tank neck to prevent contamination after filler hose removal.

- NOTE: (1) **Follow professional practice standards when working near fuel cells.**
- (2) Ensure area is clean to prevent contamination of fuel cell prior to completing 10.1.
  - (3) Early aircraft have a vent tube which exits from the side of the filler neck.

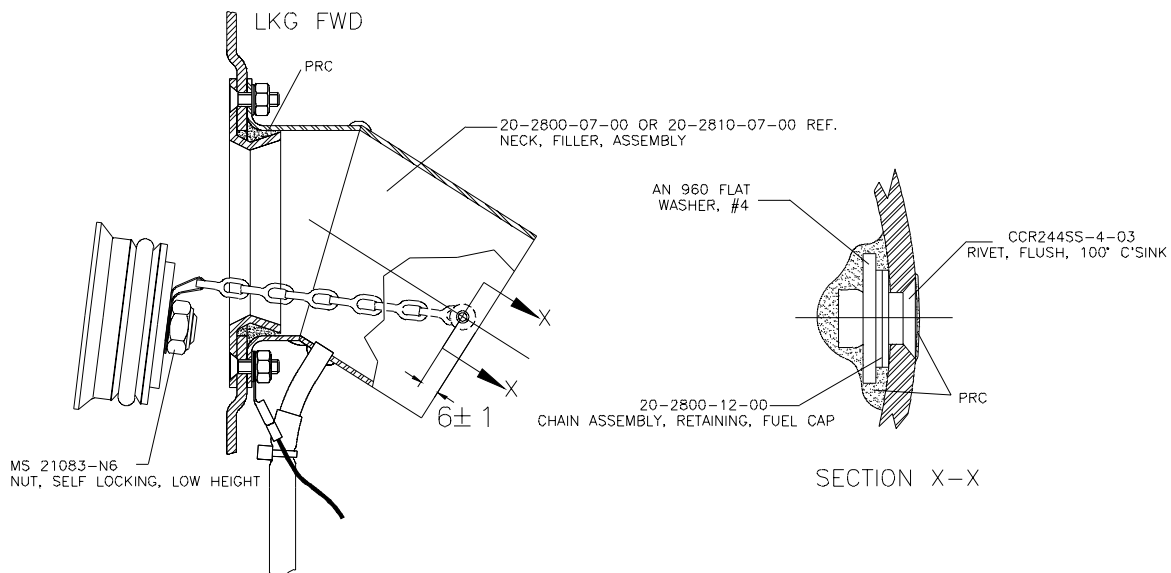

FIGURE 1.

- ### 10.2. Filler Neck Modification:
- 10.2.1 On the aft side of the filler neck (i.e. closest to the B-Bulkhead) drill a .125" / .129" hole in the filler neck shown in Figure 1.
  - 10.2.2 Countersink the .125" / .129" hole so that the rivet will just sit flush to the filler neck O.D. Deburr the hole.

**Service Bulletin No.:** DA20-28-01 Rev 0  
**Title:** Fuel Cap, Safety Chain

**Date Issued:** August. 26, 1996  
**Page:** 3 of 3

---

- 10.2.3 Rivet the chain assembly to the filler neck as shown in the section view.
- 10.3 Resealing the Installation:**
  - 10.3.1 Seal rivet with PRC fuel sealant inside and out as shown in section view.  
The coating on the filler neck O.D. should be spread flush.
  - 10.3.2 Ensure all grounding straps and vent tubes are properly installed and sealed per the maintenance manual.
  - 10.3.3 Re-install the filler hose apposite to 10.1.2.
  - 10.3.4 Attach fuel cap to chain tab and re-install nut. Nut is in safety when one thread is showing. Note: Inspect nut locking element. If it can be fully finger tightened replace. (ref AC 43.13 1A/2A)
  - 10.3.5 Lubricate fuel cap O-Ring (Fuelube or Vaseline is recommended) and install fuel cap.
  - 10.3.6 Re-install baggage floor

**11. Weight and Balance:** Not applicable

**12. Electrical Load Data:** Not applicable

**13. Credit:** Part and Labour credit will be issued upon receipt of a completed Warranty Application form if received prior to December 31, 1996.

*To obtain satisfactory results, procedures specified in this service information letter must be accomplished in accordance with accepted methods and current government regulations. Diamond Aircraft industries Inc. cannot be responsible for the quality of work performed in accomplishing the requirements of this service information letter*