

SERVICE BULLETIN



Service Bulletin No.: DA20-25-01 Rev 0

Date Issued: September 21 2011

Title: Installation of Rescue Hammer

Page: 1 of 4

1. **ATA Code:** 2560
2. **Effectivity:** All DA20-A1 Aircraft.
3. **General:** This Service Bulletin addresses the installation of a Rescue Hammer.
4. **Compliance:** Compliance with this Service Bulletin is optional.
5. **Approval:** Engineering data referenced or contained in this Service Bulletin is approved as part of the type design.
6. **Labor:** Approximately 1.0 hour will be required to accomplish this service bulletin.

This estimate is for direct labor performed by a technician and it does not include setup, planning, familiarization, cure time, part fabrication or tool acquisition.

| 7. Material: | Part Number | Description | Qty |
|--------------|---------------|------------------------------------------|------|
| | VH20BR | Rescue Hammer | 1 |
| | 22-2550-63-01 | Rescue Hammer Bracket | 1 |
| | 22-2550-63-02 | Rescue Hammer Retaining Clip | 1 |
| | BSCQ-04-05 | Blind Rivet | 2 |
| | NAS1149CN432R | Plain Washer (AN960C4) | 2 |
| | ATUM-12-4-0 | Heat Shrink | 10mm |
| | 22-1130-00-49 | Placard, Rescue Hammer, Photoluminescent | 1 |

The above material may be ordered as kit: **DA20-25-01AMK0**

8. **Special Tools:** N/A
9. **References:** DA20-A1 Aircraft Maintenance Manual, Document # DA 201

10. Accomplishment Instructions:

- 10.1 Remove the RH baggage floor as per AMM chapter 25-50-00.
- 10.2 Place the baggage floor on a suitable work table/bench.
- 10.3 Position rescue hammer bracket (p/n 22-2550-63-01) onto the baggage floor (Reference figure 1 and 2):
 - 10.3.1 Measuring from the baggage flange that attaches to the seatback, mark measurement of 155mm AFT.
 - 10.3.2 At the previously marked position, measure 20mm up from the surface of the baggage floor pocket and mark position.
 - 10.3.3 Center the forward bracket attaching hole at the marked location, verify measurements. Position upper edge of bracket parallel to upper surface of baggage floor.

10.3.4 Hold the rescue hammer bracket securely in place. Using a 1/8 inch drill bit transfer the two attaching holes to the baggage floor.

10.3.5 Open transferred holes in baggage floor using a #30 drill bit.

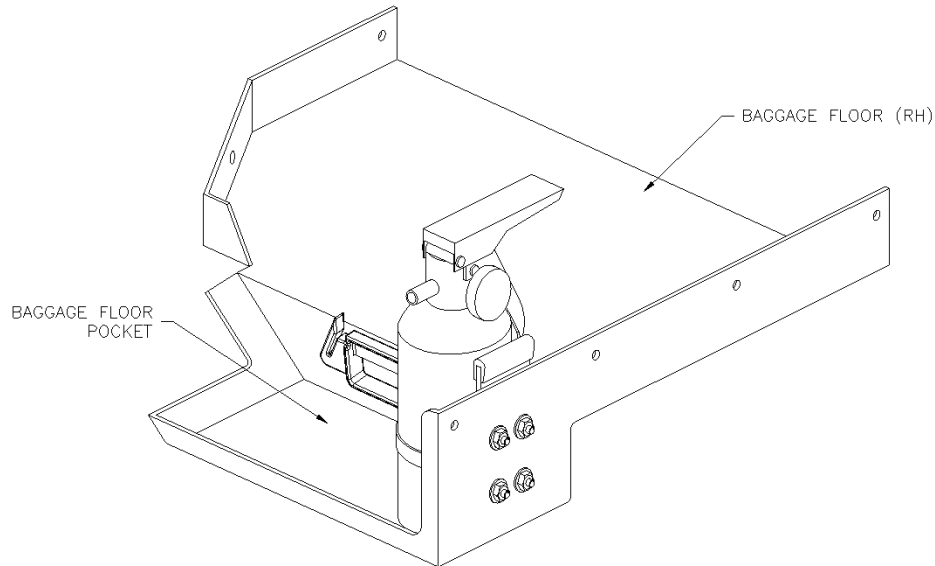

Figure 1

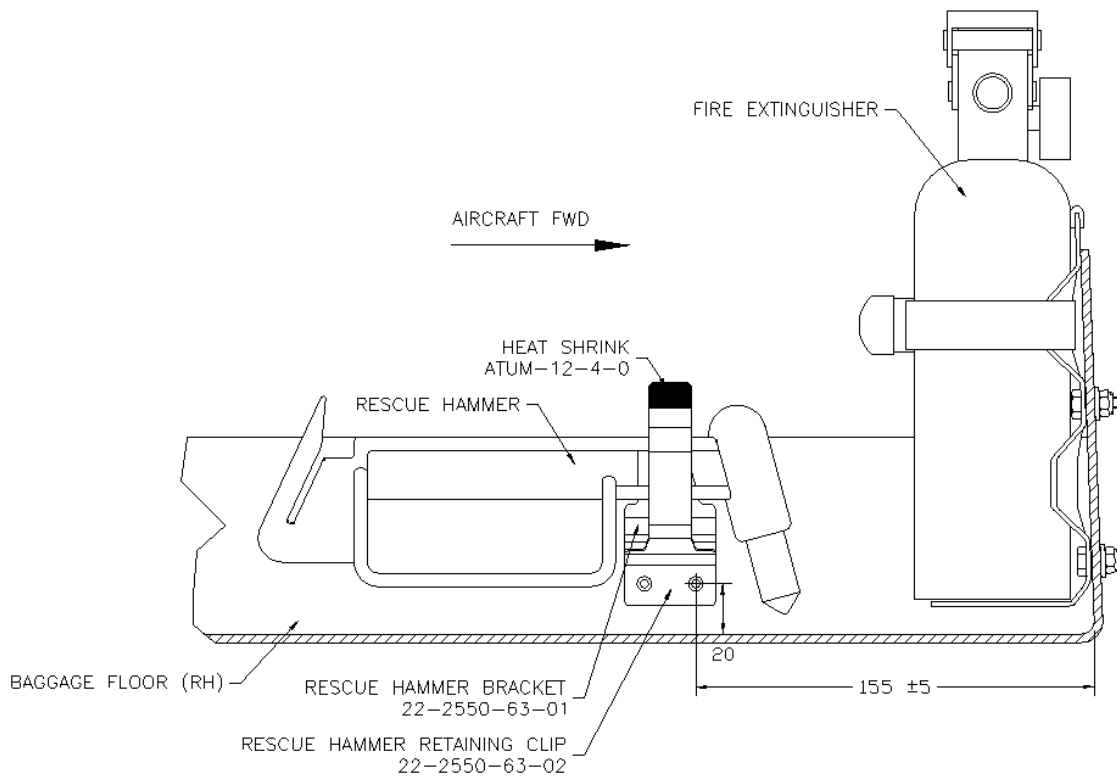

Figure 2

- 10.4 Position the rescue hammer bracket on the baggage floor. Position the rescue hammer retaining clip (p/n 22-2550-63-02) over the bracket as shown in Figure 2. Use Clecos as required.
- 10.5 Attach the rescue hammer bracket and retaining clip to the baggage floor using blind rivets (p/n BSCQ-04-05, rivet head outboard) and plain washers (p/n AN960C4). Position washers on the inboard side of the baggage floor.
- 10.6 Install heat shrink (p/n ATUM-12-4-0) on upper edge of rescue hammer retaining clip as shown in Figure 2.
- 10.7 Install the baggage floor as per AMM chapter 25-50-00. Ensure the installed rivets do not interfere with the fuel tank.
- 10.8 Install rescue hammer (p/n VH20BR) into rescue hammer bracket assembly.
- 10.9 Perform a function check of the rescue hammer removal and installation.
- 10.10 Install rescue hammer placard (p/n 22-1130-00-49) onto seatback as shown in Figure 3. Position placard in between canopy arm pivot and harness attachment.

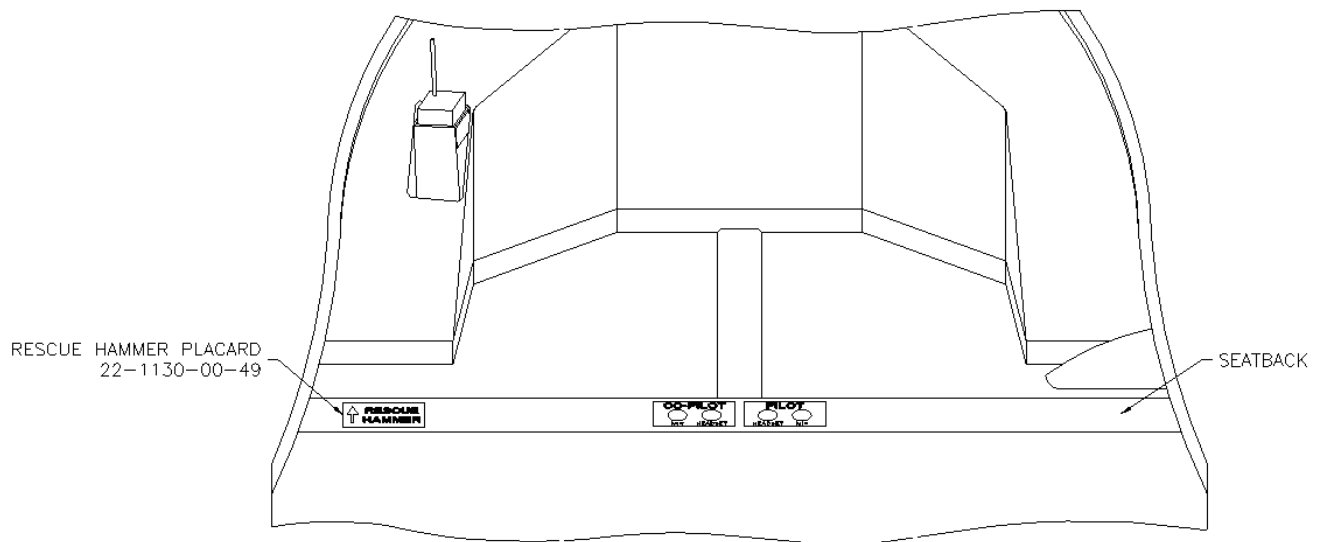

Figure 3

- 10.11 Clean the work area and inspect for foreign objects.
- 10.12 Make a log book entry that this service bulletin has been incorporated.

SERVICE BULLETIN



Service Bulletin No.: DA20-25-01 Rev 0

Date Issued: September 21 2011

Title: Installation of Rescue Hammer

Page: 4 of 4

11. Weight and Balance: Make the following adjustments to weight and balance:

| <i>Item</i> | <i>Weight (kg)</i> | <i>Arm (m)</i> |
|---------------|--------------------|----------------|
| Rescue Hammer | +0.221 | +0.790 |

12. Availability: Contact Diamond Aircraft Industries Inc.

13. Credit: None

To obtain satisfactory results, procedures specified in this service bulletin must be accomplished in accordance with accepted methods and current government regulations. Diamond Aircraft Industries Inc. cannot be responsible for the quality of work performed in accomplishing the requirements of this service bulletin. Diamond Aircraft reserves the right to void continued warranty coverage in the area affected by this Service Bulletin if it is not incorporated.

If you no longer own the aircraft to which this service bulletin applies, please forward it to the current owner and send the name of the current owner to Diamond Aircraft Industries, Inc., at the address below.

Diamond Aircraft Industries Inc. 1560 Crumlin Sideroad, London, Ontario, Canada N5V 1S2
Phone: (519) 457-4041 Fax: (519) 457-4060