

SERVICE BULLETIN

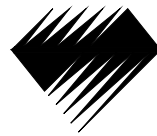

Diamond
AIRCRAFT

Service Bulletin No.: DA20-24-03, Rev. 0

Date Issued: April 18, 1997

Title: Electrical Cables, Engine Compartment

Page: 1 of 4

1. ATA Code: 2460

PLANNING INFORMATION:

2. Effectivity: DA20 Katanas S/N 10002 up to and including S/N 10300.

3. General: This service bulletin addresses the possibility of early fatigue of some ring terminals installed on heavy gauge wiring. Replacement of two electrical cables and relocation of two electrical cables located in the engine compartment is required.

4. Compliance: Recommended upon receipt of this service bulletin and parts.

5. Approval: Engineering information contained within this bulletin is approved as part of the type certificate.

6. Labor: Approximately 1.0 man hour will be required to accomplish this service bulletin.

7. Material:	Description	Part Number	Qty
Pre-assembled as Starter and Ground Cables	Wire	N46-36T-751-2	640mm or 570mm
	Ring Terminal	31811	4
	Wire Labels	RPS-16-10/2.0-9	4
	Rubber Boots	MS 25171-3S	2
	Clamp	MS 21919WDG9	1
	Bolt	AN3-C5A	1
	Bolt	AN3-16A	1
	Nut	MS 21042-3	1
	Washer	AN960-C10	2
	Washer	AN970-C3	1
	Spacer	608-090	1

The wire, ring terminals and labels are pre-assembled as two finished cables.

An inspection is required to determine the part number of the materials kit you need to order; see 'Accomplishment Instructions' 10.1 and 10.2. The kit may be ordered as DA20-24-03AMK0 (180mm starter cable) or DA20-24-03BMK0 (110mm starter cable).

8. Special Tools: None

SERVICE BULLETIN

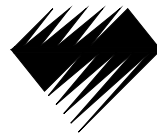

Diamond
AIRCRAFT

Service Bulletin No.: DA20-24-03, Rev. 0

Date Issued: April 18, 1997

Title: Electrical Cables, Engine Compartment

Page: 2 of 4

9. References: DA20 Maintenance Manual Doc. # DA201.

10. Accomplishment Instructions:

- 10.1 Remove the cowling.
- 10.2 Inspect the starter to see if the electrical stud for the power connection is pointing inboard or outboard. For aircraft with the electrical stud pointing inboard order material kit P/N DA20-24-03AMK0 (180mm starter cable). For aircraft with the electrical stud pointing outboard order material kit P/N DA20-24-03BMK0 (110mm starter cable).
- 10.3 Remove the old starter lead wire # 80103A4 and install the new wire cable assembly labelled #80103A4.
- 10.4 Disconnect the engine ground wire #24320A4N from the electrical shelf at one end and the #3 engine cylinder head at the other end. Remove the spiral wrap protective covering to allow removal of the wire from the harness.
- 10.5 Following the same routing install the new cable, wire #24320A4N. Reinstall the spiral wrap removed in 10.4.

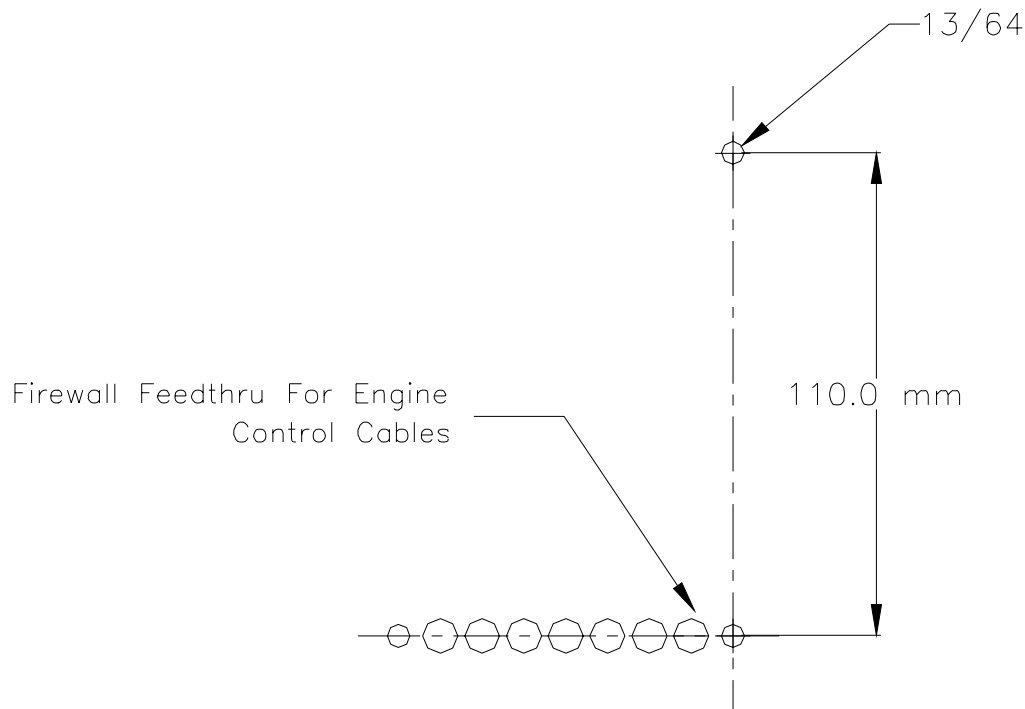

Figure 1.

SERVICE BULLETIN



Diamond
AIRCRAFT

Service Bulletin No.: DA20-24-03, Rev. 0

Date Issued: April 18, 1997

Title: Electrical Cables, Engine Compartment

Page: 3 of 4

- 10.6 Disconnect the battery wires from the battery (negative lead first). Remove the battery from the battery box.
- 10.7 Remove the clamp holding the battery wires to the air box. Discard the clamp and mounting hardware.
- 10.8 Drill a 13/64 hole in the fire wall in the location shown in figure 1.
- 10.9 Put the wires into the clamp and install the clamp as shown in figure 2 for Rotax 912 F3 installations, or figure 3 for Rotax 912 A3 installations.
- 10.10 Reinstall the battery. Reconnect the battery cables making sure that the polarity of the connection is correct.
- 10.11 Check the operation of the battery, starter, and generator.
- 10.12 Reinstall the cowlings.
- 10.13 Make a log book entry in the aircraft technical log.

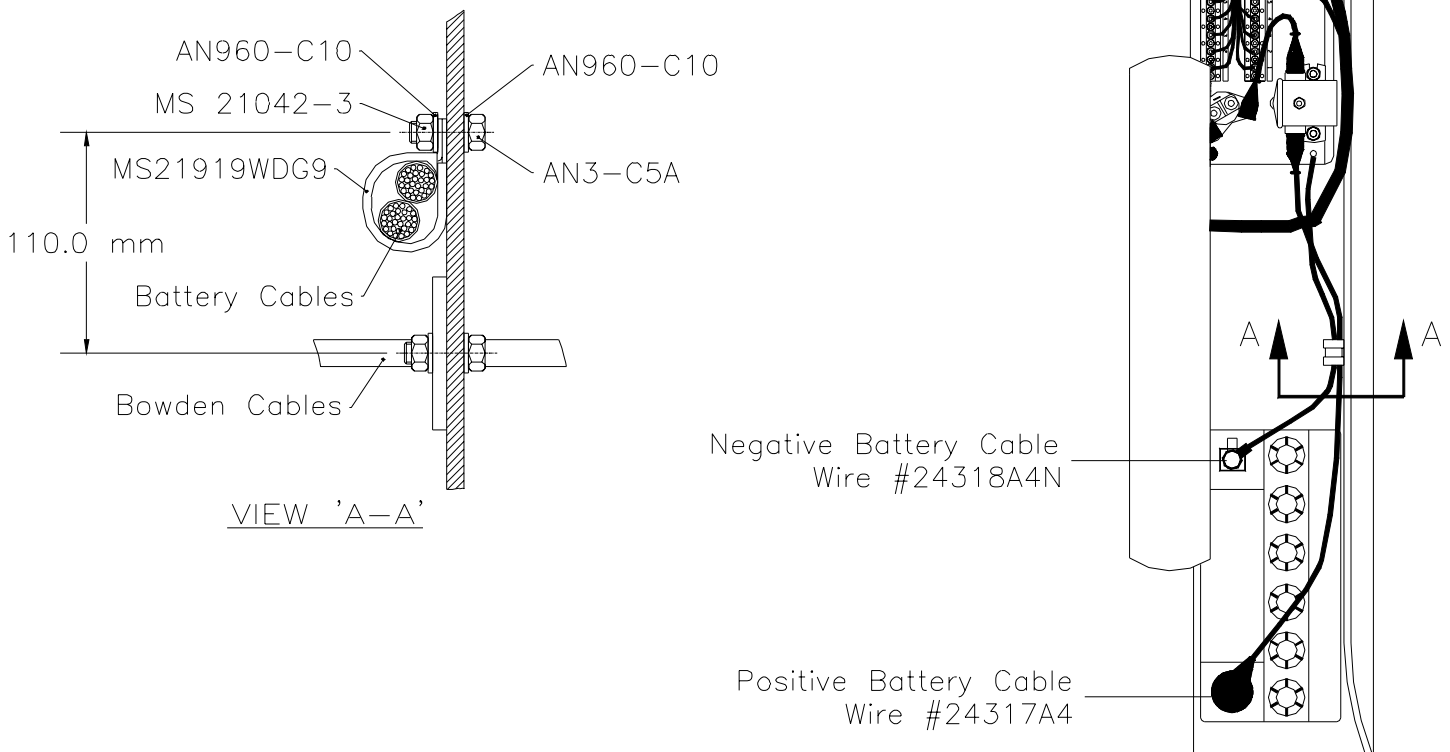

Figure 2.

SERVICE BULLETIN



Diamond
AIRCRAFT

Service Bulletin No.: DA20-24-03, Rev. 0

Date Issued: April 18, 1997

Title: Electrical Cables, Engine Compartment

Page: 4 of 4

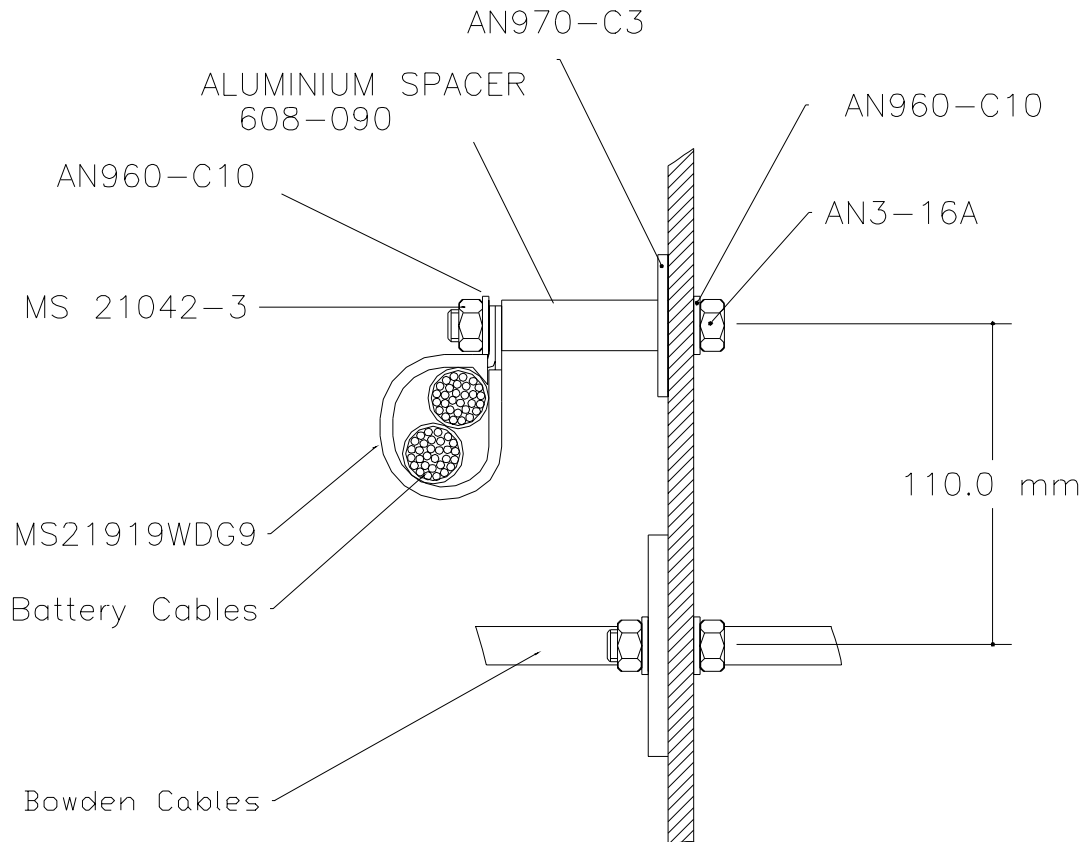

Use Spacer When Rotax 912 A3 Engine Installed

FIGURE 3

11. Weight and Balance: Negligible.

12. Electrical Load Data: Not applicable.

13. Credit: A full parts and labor credit of 1 hour will be issued upon receipt of a completed warranty claim form when received within 90 days from the issue date of this service bulletin.

To obtain satisfactory results, procedures specified in this service bulletin must be accomplished in accordance with accepted methods and current government regulations. Diamond Aircraft Industries Inc. cannot be responsible for the quality of work performed in accomplishing the requirements of this service bulletin.