

SERVICE BULLETIN



Diamond
AIRCRAFT

Service Bulletin No.: DA20-10-01, Rev. 0

Date Issued: June 19, 1996

Title: Installation, Control Lock and Fixed Provisions

Page: 1 of 3

1. **ATA Code:** 1000
2. **Effectivity:** All DA 20 Katana's up to Serial Number 100119
3. **General:** This bulletin describes the installation of the Control Lock including fixed provisions
4. **Compliance:** Recommended upon receipt of the Control Lock.
5. **Approval:** N/A
6. **Labor:** 0.5 man-hours

7. Material:	<u>Description:</u>	<u>Part Number:</u>	
	Buckle, Release (female part)	101-0100	(Qty 2)
	Bracket	20-1000-00-01	(Qty 2)
	Spacer	315-060	(Qty 2)
	Washer, Flat	AN960C10	(Qty 1)
	Bolt, Hex	AN3-5A	(Qty 1)
	Nut, Self Locking	MS21044-N3	(Qty 1)

The above material may be ordered as kit DA20-10-01MK

8. **Special Tools:** 5mm (ref. 3/16") drill
9. **References:** DA 20 Katana Maintenance Manual

10. Accomplishment Instructions:

10.1 Fixed Provisions Installation

- 10.11 Remove the Instrument Panel Cover.
- 10.12 Drill a 5mm hole in the right hand corner of the instrument panel base, as indicated in Figure 1. Deburr the hole edges.
- 10.13 Take the 'female' portion of a Release Buckle (ref. 101-0100, supplied), and fit one of the Brackets (ref. 20-1000-00-01, supplied) onto the buckle's loop end. Take one of the Spacers (ref. 315-060) and slide between the two tangs of the Bracket. Repeat this procedure for the remaining Buckle, Bracket and Spacer.
- 10.14 Attach the Buckle/Bracket/Spacer assembly to the underside of the instrument panel with the supplied hardware (ref. Hex Bolt AN3-5A, Flat Washer AN960C10 and Self Locking Nut MS21044-N3) as shown in Figure 1. Align the open mouth of the Buckle towards the Pilot's Control Stick when tightening.
- 10.15 Remove the Hex Bolt and Self Locking Nut for attaching the Hose Clamp and VMF15F11K01 Relay from the instrument panel as shown in Figure 2.
- 10.16 Remove the Hex Bolt and Self Locking Nut for attaching the Hose Clamp and VMF15F11K01 Relay from the instrument panel as shown in Figure 2.

10.1 Fixed Provisions Installation Cont'd.

10.17 Attach the second Buckle assembly to the underside of the instrument panel, and reinstall the removed hardware, Hose Clamp and Relay. Align the open mouth of the Buckle with the Pilot's Control Stick before tightening.

10.18 Reinstall the Instrument Panel Cover.

- Looking Down -

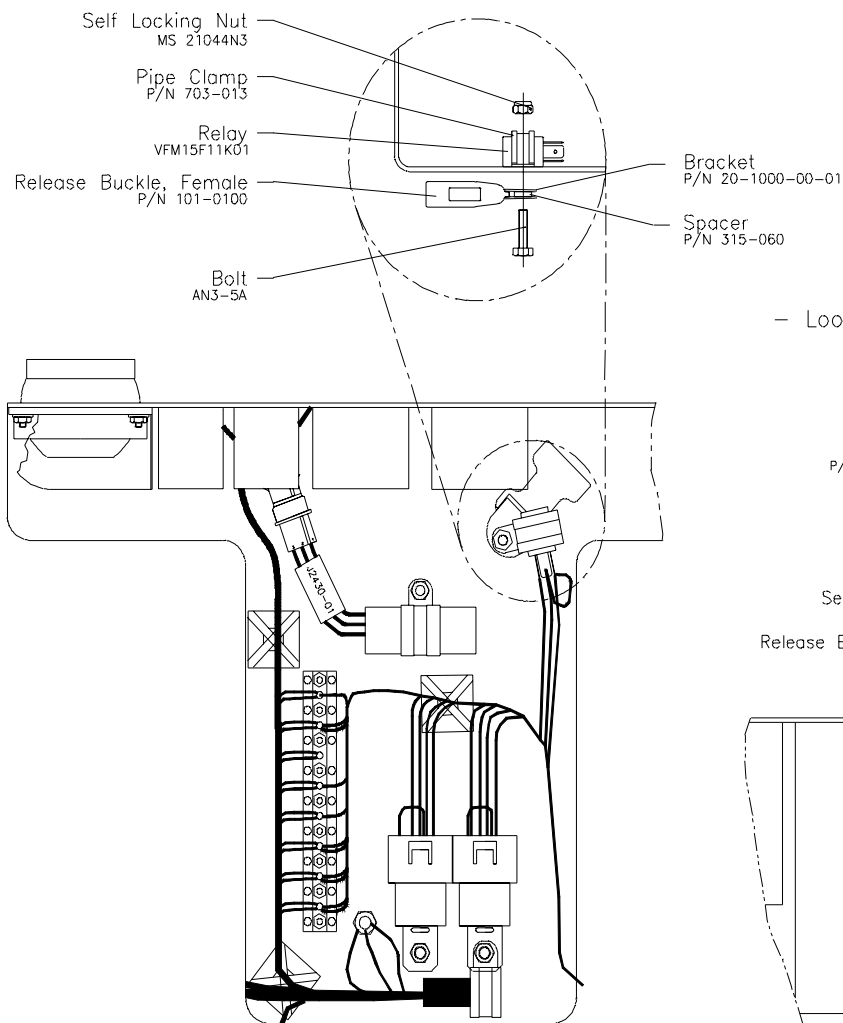
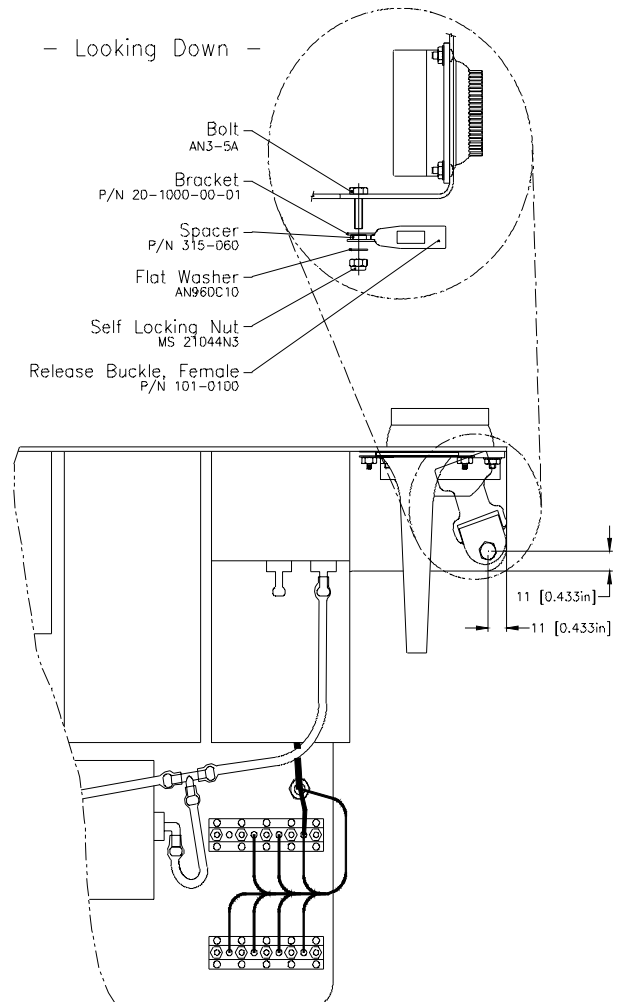

Figure 2.

Figure 1.



10.2 Installation and Removal of the Control Lock

- 10.21 Trim aircraft to zero (0) degrees.
- 10.22 Pull the pilot's rudder pedals fully aft and check they are locked in position.
- 10.23 Hook the Control Lock's forks over the rudder pedal tubes as shown in Figure 3.
- 10.24 Push down the Control Stick's leather boot to expose the Control Stick tube, and push the Control Stick forward against the Control Lock.
- 10.25 Loop the straps around the Control Stick as shown in Figure 3, and push forward on the Control Stick.
- 10.26 Clip the straps into the left and right buckle receptacles located under the instrument panel.
- 10.28 Adjust the straps as required. Straps should be tight to secure the controls properly.
- 10.29 **TO REMOVE**, push the Control Stick forward (to relieve strap tension). Unclip the straps and remove the Control Lock. Store in the aircraft's baggage compartment.

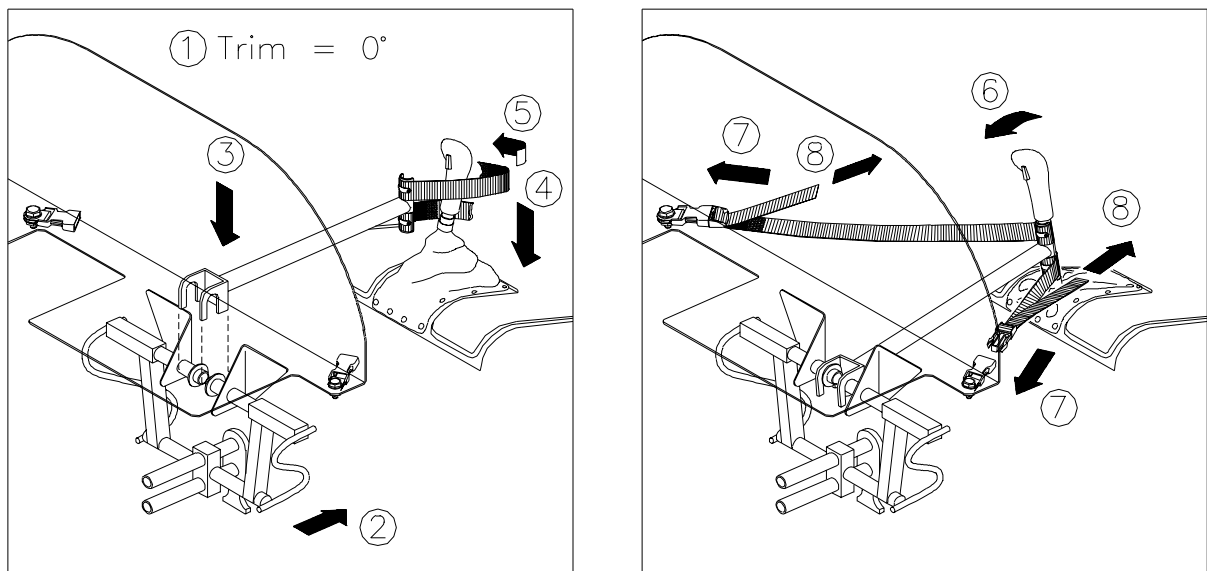

Figure 3.

11. Weight and Balance: Not Applicable

12. Electrical Load Data: Not applicable

13. Credit: None

To obtain satisfactory results, procedures specified in this service information letter must be accomplished in accordance with accepted methods and current government regulations. Diamond Aircraft Industries Inc. cannot be responsible for the quality of work performed in accomplishing the requirements of this service information letter.

Diamond Aircraft Industries Inc. 690 Crumlin Sideroad, London, Ontario, Canada N5V 1S2
Phone: (519) 457-4000 Fax: (519) 457-4037